

BOMs (PP-BD-BOM)



HELP.PPBDBOM

Release 4.6C



Copyright

© Copyright 2001 SAP AG. All rights reserved.

No part of this publication may be reproduced or transmitted in any form or for any purpose without the express permission of SAP AG. The information contained herein may be changed without prior notice.

Some software products marketed by SAP AG and its distributors contain proprietary software components of other software vendors.

Microsoft[®], WINDOWS[®], NT[®], EXCEL[®], Word[®], PowerPoint[®] and SQL Server[®] are registered trademarks of Microsoft Corporation.

IBM[®], DB2[®], OS/2[®], DB2/6000[®], Parallel Sysplex[®], MVS/ESA[®], RS/6000[®], AIX[®], S/390[®], AS/400[®], OS/390[®], and OS/400[®] are registered trademarks of IBM Corporation.

ORACLE[®] is a registered trademark of ORACLE Corporation.

INFORMIX[®]-OnLine for SAP and Informix[®] Dynamic Server[™] are registered trademarks of Informix Software Incorporated.

UNIX[®], X/Open[®], OSF/1[®], and Motif[®] are registered trademarks of the Open Group.







HTML, DHTML, XML, XHTML are trademarks or registered trademarks of W3C[®], World Wide Web Consortium, Massachusetts Institute of Technology.

JAVA[®] is a registered trademark of Sun Microsystems, Inc.

JAVASCRIPT[®] is a registered trademark of Sun Microsystems, Inc., used under license for technology invented and implemented by Netscape.

SAP, SAP Logo, R/2, RIVA, R/3, ABAP, SAP ArchiveLink, SAP Business Workflow, WebFlow, SAP EarlyWatch, BAPI, SAPPHIRE, Management Cockpit, mySAP.com Logo and mySAP.com are trademarks or registered trademarks of SAP AG in Germany and in several other countries all over the world. All other products mentioned are trademarks or registered trademarks of their respective companies.

Icons

Icon	Meaning
	Caution
	Example
	Note
	Recommendation
	Syntax
	Tip

Contents

BOMs (PP-BD-BOM)	12
Bills of Material in Production Planning.....	13
How are Bills of Material Used in PP?	14
Single-Level BOMs	15
Assemblies	16
Authorization Objects	18
Authorization Checks: Example.....	20
General Authorization Object for Processing BOMs	21
Authorization Object for BOM Plant	22
Authorization to Process BOM Without Change Number	23
Authorization Object for Mass Changes	24
Authorization Object for Variable Lists	25
BOM Categories.....	26
Effectivity.....	29
Area of Validity.....	30
Validity Period	33
Using Parameters to Define Effectivity	35
Technical Types.....	36
Which Technical Types Exist?	37
When do I Create a Variant BOM?	38
When do I Create a Multiple BOM?	40
BOM Usage.....	41
BOM Usage as a Special View on a BOM.....	42
Defining the Item Status with the BOM Usage.....	44
BOM Usage and Material Type	46
Structure of a BOM	47
BOM Header	48
Data Used to Identify a BOM.....	49
Header Detail Screen: Quantity/Long Text.....	51
Header Detail Screen: Additional Data.....	54
Header Detail Screen: Administrative Data.....	55
Document Assignments.....	56
BOM Items	58
Item Data Relevant to All Items.....	59
Item Data Relevant to Material Items	61
Item Data Relevant to Document Items	62
Item Data Relevant to Class Items.....	63
Sub-Items	65
Material BOM Browser	66
Navigation in the Material BOM Browser	67
Calling up the Browser	69

Variable Display Depth	71
Enhancements to the SAP Systems in the Area of PLM	73
Enhancements in Document Management	76
Enhancements using Customer Exits (Document)	77
Finding Recipient Lists (EXIT_SAPLCVV1_001).....	79
Screen: Basic Data for Maintaining Documents	80
Screen: Recipient Lists (EXIT_SAPLCVV1_002)	81
Determine Original Application File (EXIT_SAPLCVV1_003).....	84
Document Part and Version (EXIT_SAPLCVV1_004).....	86
Create Distribution Order (EXIT_SAPLCVV2_001)	87
Check Part Order (EXIT_SAPLCVV2_002)	88
Create Initial Order (EXIT_SAPLCVV2_003).....	89
Determine Context (EXIT_SAPLCVV5_001)	90
ITS Access (EXIT_SAPLCVVW_001).....	92
Determining the Application (EXIT_SAPLCVV1_005)	93
Enhancements using Business Add-Ins (Document).....	94
Checking Authorization from the Document Management Systems	96
Processing of Original Application Files.....	97
General Document Processing	99
General Document Processing (II).....	100
Status checks.....	101
Transport of Original Application Files	102
Checking the Attributes of the Document Key	103
Filter for DMS processes.....	104
Enhancements for Internet Scenarios.....	105
Enhancements for Microsoft Office integration	106
Enhancements using User Exits (Document)	107
Enhancements Using Customer Exits (Material Master)	109
Enhancements in the Area Engineering Change Management	111
Enhancements in BOMs	113
Enhancements Using Customer Exits (BOMs)	114
Enhancements using Business Transaction Events (BOMs).....	116
Update of a BOM (CS000010)	117
Enhancements in the Classification System	118
Enhancements in Variant Configuration	120
Archiving	123
Features of an Item Category	124
Item Categories in the Standard R/3 System	125
Item Categories for Material Items	127
Stock Items	128
Non-Stock Items	129
Variable-Size Items	130
PM Structure Elements	131
Intra Materials	132
Document Item	133
Class Items	134

Text Items	136
Entering BOM Items	137
Tab Page in the Item Detail Screen	138
Basic data	139
Identifying BOM Items	140
Entering the Same Item ID for Different Items	141
Classification Data	142
Entering Data as a Selection Condition	144
Quantity Data	145
Quantity and Unit of Measure	146
Fixed Quantity	148
Maintaining Quantity Data	149
Scrap Data	150
Assembly Scrap	151
Assembly Scrap: Example	152
Maintaining Assembly Scrap	153
Exclude Assembly Scrap	154
Component Scrap	155
Component Scrap: Example	156
Maintaining Component Scrap in the BOM	157
Maintaining Component Scrap in the Material	158
Operation Scrap	159
Operation Scrap: Example	160
Maintaining Operation Scrap	161
General Data	162
Co-Products	163
Recursiveness Check	164
Allowing Recursiveness	166
Alternative Items in an Alternative Item Group	167
Data for Alternative Items	168
Strategy: Example	169
Maintaining Alternative Items	170
Discontinuation	171
Discontinuation Data	173
Examples of Discontinuation	175
Maintaining Discontinuation Data	176
MRP Data	177
Entering a Lead-Time Offset	178
Entering a Lead-Time Offset for an Operation	181
Distribution Key	182
Special Procurement Key	183
Explosion Types	185
Switching Off the Phantom Assembly	186
Switching Off Planning	188
Switching Off Direct Production (Collective Order)	189
Long-Term Planning	190

Individual/Collective Requirements for Dependent Requirements	191
Maintaining MRP Data	192
Status/Long Text.....	193
Item Status	194
Additional Data for the Item	196
Item Text.....	199
PM Assemblies.....	200
Administrative Data	201
Variable-Size Item Data	202
Purchasing Data	204
Document Assignments.....	206
Detail Screens for a Class Item	208
Class Data	209
Class Recursiveness.....	211
Before You Create a Simple Material BOM	213
User-Specific Settings.....	214
Defining User-Specific Settings in the BOM Menu	215
Defining Default Values as SET/GET Parameters	217
Steps in Creating a Simple Material BOM	218
Maintaining the Create Material BOM Initial Screen	219
Creating New Items	221
Before You Create New Items.....	222
Creating Material Items	224
Entering Document Items	225
Entering Class Items	226
Adding Items to a BOM	227
Exiting the Item Entry Function	228
Extending Item Data	229
Entering Sub-Items.....	230
Checking and Saving Data.....	232
Other Maintenance Functions	233
Assignment to an Operation.....	234
Allocating a Component to an Operation	236
Classifying an Item	237
Maintaining Header Data.....	239
Defining the Technical Type	240
Creating a Material BOM for Additional Usages.....	241
Creating a Material BOM with an Existing BOM	243
Creating a BOM by Copying an Existing BOM with a Different Usage	245
Plant Allocations.....	246
Creating a Plant Allocation	247
Changing a Plant Allocation	249
Displaying a Plant Allocation	250
Displaying a Material BOM	251
Before You Display Your BOM	252
Validity Period	253
Required Quantity.....	254

Steps for Displaying a Simple Material BOM	256
Maintaining the	257
Displaying Component Master Data	258
Displaying a Material	259
Displaying a Document	260
Displaying a Class	262
Displaying Item Data	263
Displaying Effectivity Data for Items	264
Filtering Items	265
Filtering Items According to Effectivity	267
Sorting Items	268
Displaying Header Data	270
Displaying the Validity Data on the Initial Screen	271
Displaying Long Texts	272
Displaying an Assembly	273
Other Display Functions	274
Displaying Discontinuation Data	275
Displaying Allocations to Operations	276
Displaying Classification Data	277
Displaying Revision Levels	278
Working with Configurable BOMs	279
Creating a Variant BOM	280
Before You Create Your BOM	281
Steps for Creating a Variant BOM	283
Maintaining the Initial Screen for Creating a Variant BOM	284
Selecting a Variant BOM to Copy	286
Copying Data from an Existing Variant	287
Maintaining and Saving Variant BOM Data	288
Options for Changing Variant BOMs	289
Changing one Variant BOM	290
Options for Displaying Variant BOMs	291
Displaying One Variant BOM	292
Creating a Multiple BOM	293
Before You Create Your BOM	294
Steps to Creating a Multiple BOM	296
Initial Screen for Creating a Multiple BOM	297
Copying an Existing BOM	299
Copying Items from the Existing BOM	300
Maintaining and Saving Multiple BOM Data	301
Options for Changing a Multiple BOM	302
Changing one Alternative in a Multiple BOM	303
Options for Displaying a Multiple BOM	304
Displaying one Alternative in a Multiple BOM	305
Displaying an Alternative from the Alternative Overview	306
BOM Changes in the SAP R/3 System	307

Changes Without History	308
History Requirement for BOMs	309
Engineering Change Management for BOM Changes	310
Transaction Processing Using an ECR	311
Change Master Records	312
Object Management Records and BOM List	313
Revision Levels	315
Before You Change a BOM	317
Changing a Material BOM	318
Steps for Changing a BOM	319
Change Material BOM Initial Screen	320
Maintaining Item Data	322
Changing Items on the Item Overview.....	323
Changing Item Data on a Detail Screen.....	325
Creating New Items.....	327
Deleting Items.....	328
Entering Sub-Items	329
Deleting Subitems	331
Changing a BOM Header	332
Changing Classification Data	334
Maintaining the Revision Level	335
Assigning a Revision Level to a Material.....	336
Changing a Revision Level.....	337
Displaying a Revision Level.....	338
Changing an Operation Allocation	339
Changing a Variant BOM - Special Points	341
Changing a Multiple BOM - Special Points	342
Deleting a Material BOM	343
Carrying Out the Delete Function	344
Mass Changes	346
Starting a Mass Change	348
Executing Mass Changes	350
Reading the Log for Mass Changes	352
BOM Reporting Functions	353
User-Specific Settings for BOM Reporting	354
Display Profile for Lists	355
Standard Profiles for Reporting Lists.....	357
Maintaining a New List Profile.....	358
Creating a New List Profile.....	359
Displaying the Standard Profile (Display Blocks).....	360
Display Blocks: Example.....	362
Creating Display Blocks for the New Profile.....	363
Processing New Display Blocks.....	364
Checking a New Profile.....	365
Entering User Defaults for a List Profile.....	366
Program Names for Reporting Functions.....	367
Printing Reporting Lists	368

BOM Explosion	369
Alternative Determination Using the Application	370
Defining an Application	371
Selecting a BOM for the Explosion	373
Entering Effectivity Parameters	374
Selection Criteria for BOM Explosion	376
Defining a View for BOM Explosion	377
Restricting the View for BOM Explosion	380
Extending the Views for BOM explosions	383
BOM Explosion Level by Level	385
Displaying a Multi-Level BOM Explosion	387
Displaying a Summarized BOM	389
Additional BOM Explosion Functions	390
Displaying Item Data from a BOM Explosion	391
Displaying Master Record Detail Data	392
Displaying a Where-Used List from a BOM Explosion	393
Displaying a Multi-Level BOM in Graphical Form	394
When is a Material BOM Not Exploded?	396
When is a BOM Explosion Terminated?	397
Where-Used List	398
Defining a Where-Used List on the Initial Screen	399
Selection Criteria for the Where-Used List	401
Defining a View for a Where-Used List	402
Restricting the View for a Where-Used List	404
Extending the View for a Where-Used List	405
Where-Used List for a Material	406
Where-Used List for a Document	407
Where-Used List for a Class	408
Exception Messages for a Where-Used List	409
Additional Functions for a Where-Used List	410
Displaying Item Data from a Where-Used List	411
Displaying Detail Data from a Where-Used List	412
Displaying a Where-Used List from a Where-Used List	413
BOM Comparison	414
BOMs for a BOM Comparison	415
Settings for a BOM Comparison	416
Executing a BOM Comparison	418
Understanding the BOM Comparison Result	419
Displaying Change Documents	421
Displaying Change Documents from the Main Menu	422
Displaying Change Documents from the BOM	424
Setting up BOM Groups	425
Hints on Changing a BOM Group	427
Changing BOM Groups	428
Displaying a BOM Group	430
Before You Display a BOM Group	431
Maintaining the for Display BOM Group Initial Screen	432
Displaying a Summarized BOM Group	433

BOMs (PP-BD-BOM)

Definition

A formally structured list of the components that make up a product or assembly. The list contains the object number of each component, together with the quantity and unit of measure.

BOMs are used in their different forms in various situations where a finished product is assembled from several component parts or materials. Depending on the industry sector, they can also be called recipes or lists of ingredients and so on.

They contain important basic data for numerous areas of a company, for example:

- MRP
- Material provisions for production
- Product costing
- Plant maintenance

You can create the following BOMs in the SAP system:

- Material BOMs
- Equipment BOMs
- Functional location BOMs
- Document structures
- Order BOM
- Work breakdown structure (WBS) BOM

Selection Criteria

Selection is necessary if you plan production in the R/3 System or if you want to maintain BOMs for technical objects from the area plant maintenance. If very large documents about BOMs are to be cumulated in the document management system (DMS), you also have to select these components.

Bills of Material in Production Planning

Production Planning in the SAP R/3 System

The Production Planning application component provides a solution for both the production plan (type and quantity of the products) and the production process. Preparations for production include the procurement, storage, and transportation of materials and intermediate products.

Bills of Material in Production Planning

Bills of material (BOMs) and routings contain essential master data for integrated materials management and production control. In the design department, a new product is designed such that it is suitable for production and for its intended purpose. The result of this product phase is drawings and a list of all the parts required to produce the product. This list is the bill of material.

German standard (DIN) number 199, part 2, number 51, defines a bill of material as follows:

A bill of material is a complete, formally structured list of the components that make up a product or assembly. The list contains the object number of each component, together with the quantity and unit of measure.

A bill of material can only refer to a quantity of at least 1 of an object.

The graphic below shows some components of a bicycle that are included in a BOM.

	Pre-assembled frame and forks	FRAME01	1	PC
	Handlebar assembly	HBA	1	PC
	Derailleur gear system	GEARS	1	PC
	Bottom bracket bearing	BEAR	1	PC
	Saddle	SADDLE	1	PC
	Saddle support	SADSUP	1	PC

Bills of material are used in their different forms in various situations where a finished product is assembled from several component parts or materials. Depending on the industry sector, they may also be called recipes or lists of ingredients. The structure of the product determines whether the bill of material is simple or very complex.

How are Bills of Material Used in PP?

How are Bills of Material Used in PP?

The data stored in bills of material serves as a basis for production planning activities such as:

- A design department (working with CAD) can base its work on bills of material. You can also create a BOM in the R/3 System from your CAD program, via the SAP-CAD interface.
- A material requirements planning (MRP) department explodes bills of material on a certain date to calculate cost-effective order quantities for materials.
- A work scheduling department uses bills of material as a basis for operation planning and production control.
- A production order management department, uses bills of material to plan the provision of materials.

The data stored in bills of material is also used in other activities in a company such as:

- Sales orders
As an aid to data entry. You can also create and maintain a BOM specifically for a sales order (variant configuration).
- Reservation and goods issue
As an aid to data entry
- Product costing
To calculate the costs of materials required for a specific product

This simultaneous use of BOM data in different areas of a company illustrates the advantage of a system based on integrated application components. Links between application components facilitate continuous data exchange between different application areas, giving all users access to the latest data at all times.

Single-Level BOMs

You can break down large and complex product structures into a number of related units. Each unit can be represented by a BOM, referred to in this documentation as a **single-level BOM**.

A single-level BOM describes one or more assemblies by means of component quantities. In the following, the term single-level BOM will be shortened to **BOM**.

In practice, a single-level BOM is often a collection of standardized assemblies. A single-level BOM can be either a complete machine or an individual part.

You can use single-level BOMs to define one-time solutions for recurring tasks. Once you have defined your solution in the form of a single-level BOM, you can use it whenever you need it and combine it with other BOMs as required.



The graphic below shows single-level BOMs for a men's racing bicycle for different levels of the production process.

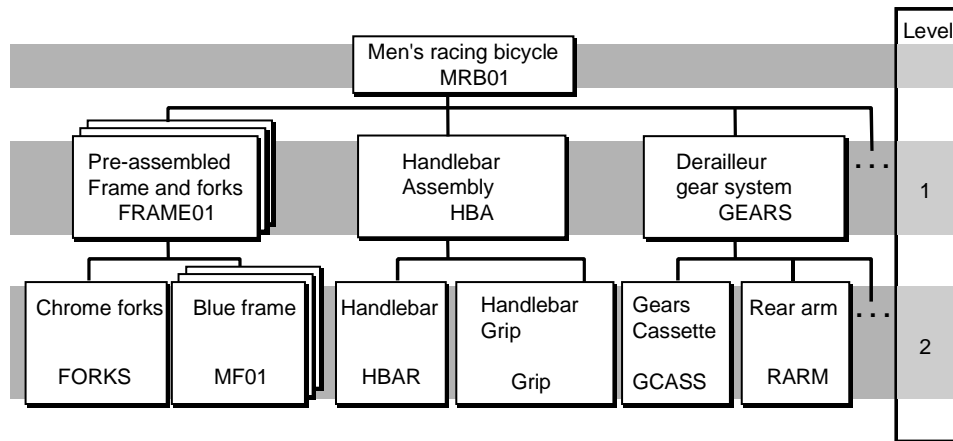

Assemblies

Assemblies

A group of semi-finished products or parts that are assembled together and form either a finished product or a **component** of a finished product is known as an **assembly**.

An assembly is identified by a material number and generally functions as a single unit.

The graphic below shows the assembly "GEARS", a Derailleur gear system that is made up of four components.

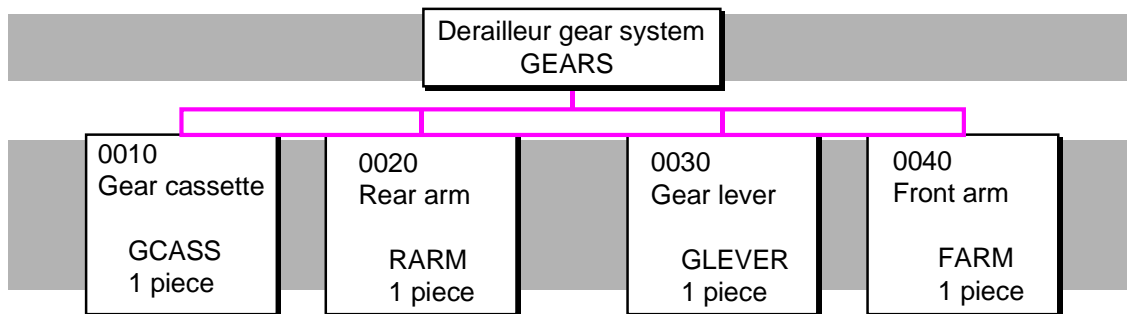

A product defined as an assembly, such as the Derailleur gear system in the graphic above, can in turn be used as a component in another assembly, such as **MRB01 Men's racing bicycle** (see graphic in topic Single-Level BOMs).



The term "assembly" comes from material BOM applications. In document structures (in *document management* applications) this term refers to a coherent grouping of a quantity of documents and texts.

Phantom Assemblies

A phantom assembly is a logical (rather than functional) grouping of materials.

- From the design point of view, these materials are grouped together to form an assembly. The components of a phantom assembly are grouped together to be built into the assembly on the next level up the product structure.
- From the production point of view, these materials are not actually assembled to form a physical unit.



Assembling a pair of gearwheels

Engineering/design view: one assembly

Assembly view:

Gearwheel 1 goes into the driving gear

Gearwheel 2 goes into the output gear

You can define the special procurement key *phantom assembly* in the material requirements planning (MRP) data of the material master record for a material.

Assemblies

Dependent requirements for the superior assembly are passed directly down to the components of the phantom assembly, skipping the phantom assembly. Planned orders and purchase requisitions are also produced only for the components of the phantom assembly.

Authorization Objects

Authorization Objects

You can organize BOM processing in your company to suit the way your company is structured. It is often the case that basic data that is relevant to all applications is created in a central department, then application-specific data is added using the change function.

You can structure authorizations to reflect your organization. The 4 authorization objects for defining access authorizations are assigned to object class *Production planning*.

The following authorization objects are defined for maintaining BOMs:

- [General Authorization Object for Processing BOMs \[Page 21\]](#)
- [Authorization Object for BOM Plant \[Page 22\]](#)
- [Authorization to Process BOM Without Change Number \[Page 23\]](#)
- [Authorization Object for Mass Changes \[Page 24\]](#)
- [Authorization Object for Variable Lists \[Page 25\]](#)

Checking Authorization Objects

The following table shows which functions check which authorization objects.

Function	Authorization object
Create BOM, change BOM	C_STUE_BER (bill of material) C_STUE_WRK (plant) C_STUE_NOH (change without history)
Mass changes	C_STUE_MAS C_STUE_BER (bill of material)
Archive BOM	C_STUE_BER (bill of material) C_STUE_WRK (plant)
Display BOM, BOM group, and plant allocation	C_STUE_BER (bill of material) C_STUE_WRK (plant)
BOM explosion, where-used list, BOM comparison	C_STUE_BER (bill of material)
Display change documents	S_SCD0 (change documents)
Variable lists for BOM explosions	C_VARLIST (objects for variable lists)

The documentation assumes that the user has unrestricted authorization for all functions.

[Authorization Checks: Example \[Page 20\]](#)

Authorization Checks: Example

Authorization Checks: Example

The authorization object *BOM plant* (plant allocation) is defined for two users. Both have the value 01 (create and allocate) entered in the *Activity* field.

However, they have different values for the *Plant*.

- **User A** has the values 0001, 0002, and 0003.
- **User B** has the value 0001.

If these two users want to extend the area of validity of a BOM in plant 0001 to include plants 0002 and 0003, the difference takes effect. **User A** is allowed to make this allocation. **User B** is not authorized to create BOMs in plants 0002 and 0003, so **User B** cannot make the allocation.



Additional authorization checks are carried out for engineering change management, document management, and other related application areas. For more detailed information, see the documentation on the individual application concerned.

General Authorization Object for Processing BOMs

General Authorization Object for Processing BOMs

This authorization object allows you to restrict access to BOM maintenance functions. When you try to start a BOM function, the program checks this authorization object. If a change is made to the authorization object while you are processing a BOM, another check is made automatically.

Fields in Authorization Object C_STUE_BER

Fields	Possible values	Description
ACTVT (activity)	01 02 03 06 24 41	Create Change Display Delete Create archive file Delete from database
STLTY (BOM category)	M E D K S T	Material BOM Equipment BOM Document structure Order BOM Standard BOM Functional location BOM
STLAN (BOM usage)	These field values are defined in Customizing.	
BEGRU (authorization group)	0000-ZZZZ	Used to further restrict authorizations for BOM maintenance (BOM header)

Authorization Object for BOM Plant

Authorization Object for BOM Plant

This authorization object allows you to protect the allocation of a BOM to a plant.

Fields in Authorization Object C_STUE_WRK

Fields	Possible values	Description
ACTVT (activity)	01 02 03	Create Change Display
CSWRK (BOM plant)		Enter the plant where the activity can be performed.
STLAN (BOM usage)	These field values are defined in Customizing.	

Authorization to Process BOM Without Change Number

Authorization to Process BOM Without Change Number

Authorization object **C_STUE_NOH** lets you maintain a BOM that has a history requirement without a change number.

The authorization object contains field NOHIS (authorization to change BOMs without a change number). To assign this authorization, enter X.



Only assign authorization object C_STUE_NOH in exceptional situations, because this authorization means that changes to BOMs will no longer be fully documented.

Authorization Object for Mass Changes

Authorization Object for Mass Changes

Authorization object **C_STUE_MAS** determines whether you can make mass changes to bills of material. This authorization object is checked when you call the mass change function.

The authorization object contains field *ACTVT* (activity). You enter the value 16 (execute) in this field.

Authorization Object for Variable Lists

This authorization object lets you restrict maintenance of the following objects in variable lists:

- List name
- Profile
- Maximum block
- Display block

For BOM reporting functions, you can define company-specific variable lists for on-screen display and printouts.

Fields in Authorization Object C_VARLIST

Fields	Possible values	Description
ACTVT (activity)	01 02 03 16 21	Create Change Display Execute (use of profile in reporting lists) Transfer list name
BEGRU (authorization group)	0000-ZZZZ	Used to further restrict maintenance authorizations

BOM Categories

BOM Categories

In the SAP System, you can use BOMs to represent different objects (such as materials, equipment, functional location BOMs, and documents) and to maintain object-specific data. Before you can create a BOM for the component parts of an object, the object must have a valid master record in your system.

The following graphic shows the objects for which you can create BOMs.

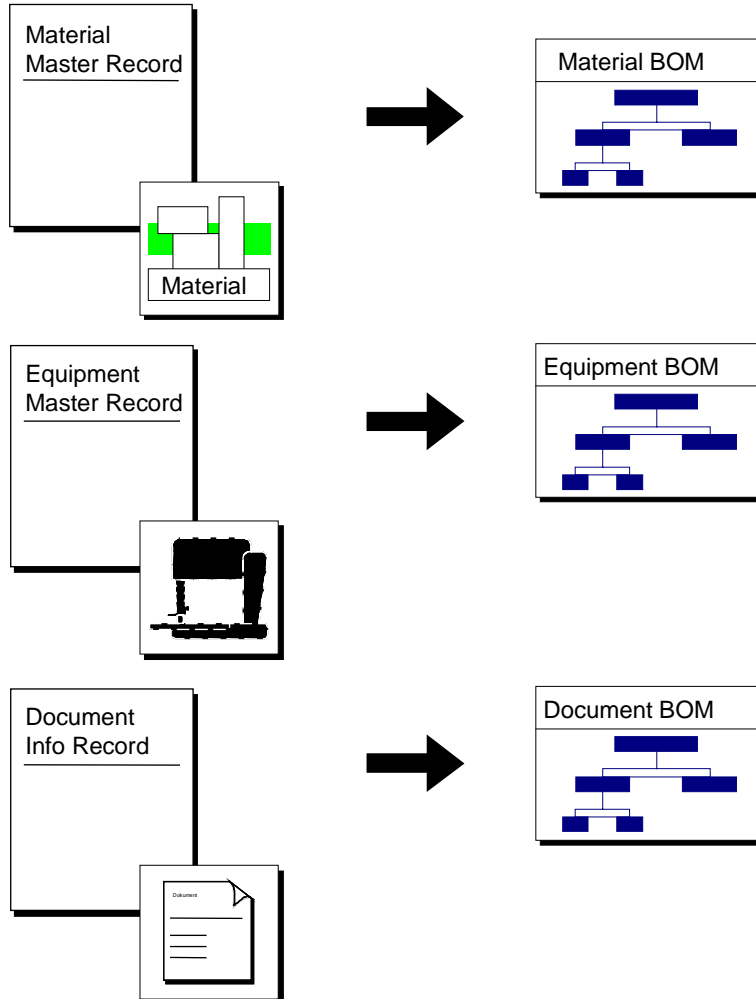

Material BOM: BOM with Reference to a Material

A bill of material that you create for a material is known as a *material BOM* in the SAP System.

To create a material master in the SAP System, you can use the following functions:

- *Material* → *Create* → *Immediately*

For this material, the system creates a material master immediately, so you can also create a BOM for it.

- *Material* → *Create* → *Schedule*

For this material, the system only generates a change document. This is why you cannot create a BOM for the material at first.

Only when you activate the scheduled material does the system create a material master record. Then you can create a BOM for it.

The material master record contains descriptive data such as the size, dimension, and weight of the material, and control data such as the material type and the industry sector. In addition to this user-maintained data, the material master record also contains data that is updated by the system, such as stocks.

Material BOMs are mainly used to represent the structure of products manufactured within your company. You can enter both materials and documents as components of this BOM. A document info record must exist in your SAP System for each document you enter.



This documentation uses the example of the material BOM to describe BOM functions.

Document Structure: BOM with Reference to a Document

A complex document may be made up of several documents, such as a program, technical drawings, papers, and photographs. These related information and documentation objects are grouped together as a unit using a document structure – a BOM for a document.

In effect, you create a BOM for a **document info record**. This “BOM” is known as a *document structure*.

You can find additional information on how to maintain document structures in the component CA – *Document Management System*. In the SAP-Library select *Cross-Application Components* → *Document Management System*.

Equipment BOM: BOM with Reference to an Equipment

The system also allows you to maintain BOMs for **equipment** (technical objects for plant maintenance).

Equipment BOMs are used to describe the structure of equipment and to assign spare parts to equipment for maintenance purposes.

Since these BOMs are linked to equipment, they are known as *equipment BOMs*.

You can find additional information on how to maintain equipment BOMs in the component PM – *Maintenance Bill of Material*. In the SAP-Library select *Logistics* → *PM - Plant Maintenance* → *Technical Objects* → *PM - Maintenance Bill of Material*.

Functional Location BOM: BOM with Reference to a Functional Location

Bills of material for **functional locations** group together the elements of a technical structure, such as the functional unit of an entire plant.

In the standard SAP System, a master record exists for each functional location. BOMs of this category are linked to these master records. This is why they are known as *functional location BOMs*. A functional location BOM can contain materials (PM structure elements and items relevant to plant maintenance) and documents.

BOM Categories

You can find additional information on how to maintain functional location BOMs in the component PM – *Maintenance Bill of Material*. In the SAP-Library select *Logistics* → *PM - Plant Maintenance* → *Technical Objects* → *PM - Maintenance Bill of Material*.

Order BOM: BOM with Reference to a Sales Order

You work with order BOMs when you specially tailor the make-to-order production of your products to the requirements of your customers. In order to meet the customer requirements, sales order specific modifications to various assemblies are often required. Furthermore, assemblies are often specially constructed for a particular sales order.

The order specific, modified or created BOMs are saved with reference to materials, sales orders, and sales order items. BOMs of this category are linked to **sales orders**, so they are known as *sales order BOMs* or *order BOMs*.

You can create order BOMs using the variant configuration as well as the BOM processing function.

The [Orderbrowser \[Ext.\]](#) is a navigation tool that you can use to get an overview of the multi-level BOMs of a sales order item and which you can use to navigate the various process and evaluation functions.

You can find additional information on how to maintain order BOMs under *PP – Order BOMs*. In the SAP-Library select *Logistics* → *PP – Production Planning and Control* → *Basic Data* → *Order BOMs*.

Work Breakdown Structure BOM: BOM with Reference to a Production Lot

Production lots for finished and semi-finished products can be planned and manufactured using different BOMs. For example, a substituted component can trigger a targeted cost calculation and evaluation per production lot during the planning stage (before sales).

The number of a production lot is a WBS element from the Project System. You use this number to plan and manufacture the production lot for an assembly, and calculate the planned and actual costs for producing the assembly.

Because of the reference to a **WBS element** from the **Project System**, these BOMs are known as WBS BOMs.

You can find additional information on how to maintain WBS BOMs under *PP – Planning Production Lots / Engineer-to-Order Production*. In the SAP-Library select *Logistics* → *PP – Production Planning and Control* → *Basic Data* → *Planning Production Lots / Engineer-to-Order Production*.

Effectivity

In the standard system, validity areas and periods are used to define the precise conditions under which a bill of material is valid in different areas of a company.

See also:

[Area of Validity \[Page 30\]](#)

[Validity Period \[Page 33\]](#)

Time-related changes do not always reflect company-specific processes in R/3 sufficiently. For this reason, you can define company-specific effectivity conditions.

See also:

[Parameter effectivity \[Page 35\]](#)

Area of Validity

Area of Validity

Material BOMs can be valid on different organizational levels:

- You can use a material BOM to manage data that applies directly to production. This is why the area of validity is the **plant**. The plant is the location where all necessary work-scheduling procedures are organized, such as MRP and creating routings. In this case, you create a plant-specific BOM.
- However, you can also create a *group BOM*, **without** reference to a plant. For example, a designer maintains a group BOM during the design phase of a product, then the BOM is allocated to one or more plants for production purposes.



You can extend the area of validity of a BOM by allocating the same BOM to a material in different plants.

Group BOM

If you create a material BOM **without** reference to a plant, the BOM is valid throughout your company. To do this, you leave the *Plant* field blank. The system checks whether material masters exist. There are no system checks for plant data.

Plant-Specific Material BOM

If you create a material BOM **with** reference to a plant, the system makes a number of checks. A material master record with plant data for the relevant plant must exist for the BOM header material. When you enter items, the system checks whether plant data exists for the material components (see *Extending the Area of Validity*).

The following graphic shows the checks for creating a material item in a plant-specific BOM. First, the system checks whether the material master record exists. Then the system checks the plant-specific material data. If these checks are successful, the system accepts the material in the material BOM.

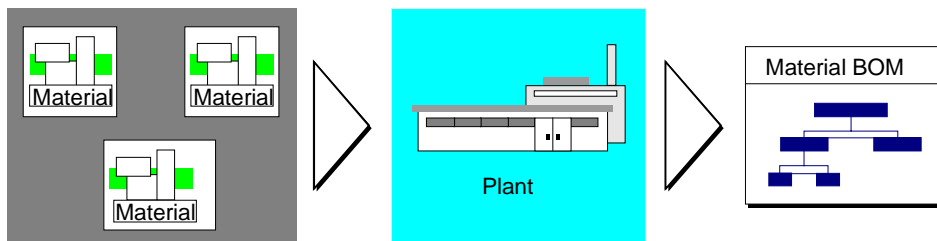

You create equipment BOMs for a specific maintenance planning plant. However, equipments are managed at client (group) level, not at plant level. Usually, the system checks plant data for a BOM item, but there is a special item

Area of Validity

category for BOM items that are relevant to *plant maintenance*, so the system does not check plant data for these items.

Extending the Area of Validity

You can extend the area of validity (plant or group) that was defined when a BOM was created. To do this, you allocate the same bill of material to a material in different plants.

- You can allocate a BOM created in a specific plant (such as 0001) to additional plants (such as 0002 and 0003) or to the entire group (blank).
- You can allocate a group BOM to individual plants.



These related BOMs are identified in the R/3 System by a common internal BOM number. This internal BOM number is displayed on all screens for plant allocations.

Before you can allocate the same BOM to a material in different plants, the following must apply:

- The material whose BOM you want to allocate to an additional plant must have a material master record in the new plant.
All material items in the BOM must have valid material master records in the new plant.



If the BOM is only relevant to plant maintenance, you can allocate the BOM to plants where no plant data exists.

- If the unit of issue is maintained in a BOM item, this unit must be the same in all plants.
- If the BOM contains a non-stock item that has a cost element, the system checks the account.

If the cost element is for primary costs, the system checks whether the G/L account exists for the company code. The system uses the valuation area and the plant to which the BOM is allocated to determine the company code.

Secondary costs are only maintained in cost accounting.

- Before you can allocate a BOM to one or more additional plants, authorization object *BOM plant authorization* in your user profile must contain the required values.

The following graphic shows how the same BOM is allocated to a material in different plants.

Area of Validity

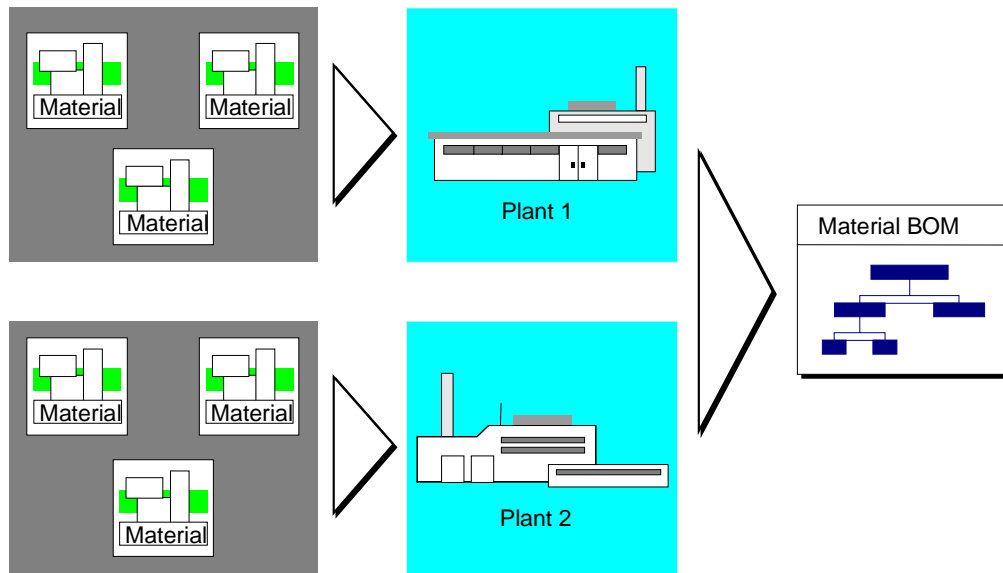

If you want to allocate the BOM for a material to a plant where the material already has a multiple BOM (identified by the same internal BOM number), you can only allocate one alternative from this BOM group to the material in this plant.

Plant allocations are also supported for equipment BOMs and functional location BOMs.

Validity Period

In the standard system, the effectivity of a BOM header or BOM item is defined by time, using the *Valid-from* date. For example, a BOM has 4 items instead of 3 as of December 12, 1999.

The validity period is the time during which the BOM header or BOM item is valid. This period is delimited by the following data in the BOM header and BOM item:

- **Valid-from dates**

When you create a BOM, this date determines the point in time at which this BOM becomes effective.

If you create or change a BOM using a change number, the system takes the valid-from date from the change master record.

- **Valid-to dates**

This date determines the end of the validity period of the BOM. The system default is December 31, 9999. If you change a BOM using a change number, the system determines the valid-to date dynamically.

If you change a BOM using a change number with a valid-from date, the pre-change validity period of the BOM header or BOM item ends at exactly 00.00 hours on this valid-from date.

If you change a BOM header or a BOM item with a change number, you generate 2 validity periods, as shown in the following example.



In a BOM, you replace component A with component B using a change number with a specific valid-from date (t_1). The system saves both the status of the BOM before the change with the old component A and the status of the BOM after the change with the new component B.

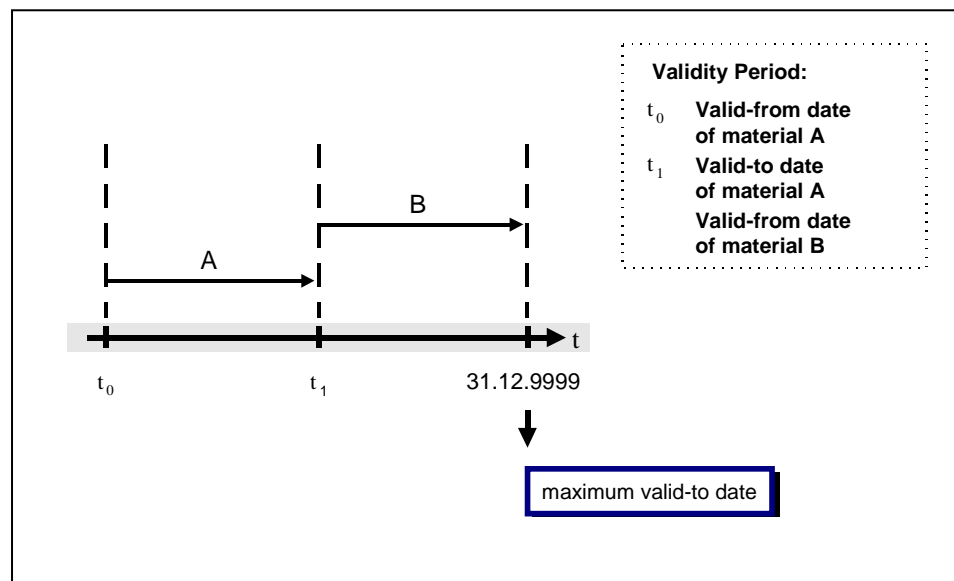

Validity Period

You can assign a revision level to these validity periods. In overviews, you can display all validity periods of the BOM headers or BOM items.

Under certain circumstances, the sequence of validity periods can change.

Using Parameters to Define Effectivity

Use

If you want to use company-specific criteria (instead of dates) to determine when changes are effective, you can use parameters to define effectivity.

The standard SAP System provides 2 effectivity types (time period and serial number range).

For example, effectivity type *time period* lets you react quickly to seasonal changes in the market by defining a change to a product (such as color or extras) for a specific time period.

If you want to use other, company-specific effectivity conditions, you can define your own effectivity types in the SAP System.

Integration

In Customizing for *Engineering Change Management*, parameters (such as material or serial number) are defined and assigned to an effectivity type. These functions are termed *parameter effectivity*.

The change master record determines which effectivity conditions apply when you change a BOM. You can either create a change master record with date effectivity (*Valid-from date*) or with parameter effectivity.

You control the effectivity parameters by selecting an effectivity type (for example, SERNR – serial number range). By entering values for the parameters that make up an effectivity type, you define the exact conditions under which the object changes are effective.

Prerequisites

Before you can use parameter effectivity to define when changes to BOMs are effective, you must define the following settings in Customizing for *Logistics General* → *Engineering change management*:

Detailed information can be found in the SAP library under *Logistics* → *Logistics - General* → *Engineering Change Management* → [Working with parameter effectivity \[Ext.\]](#).

Technical Types

Technical Types

When you first create a BOM for a material, the system automatically creates the first alternative. The technical type of the BOM is not yet defined, so the technical type is " " (blank). The following graphic shows the structure of a "simple" BOM.

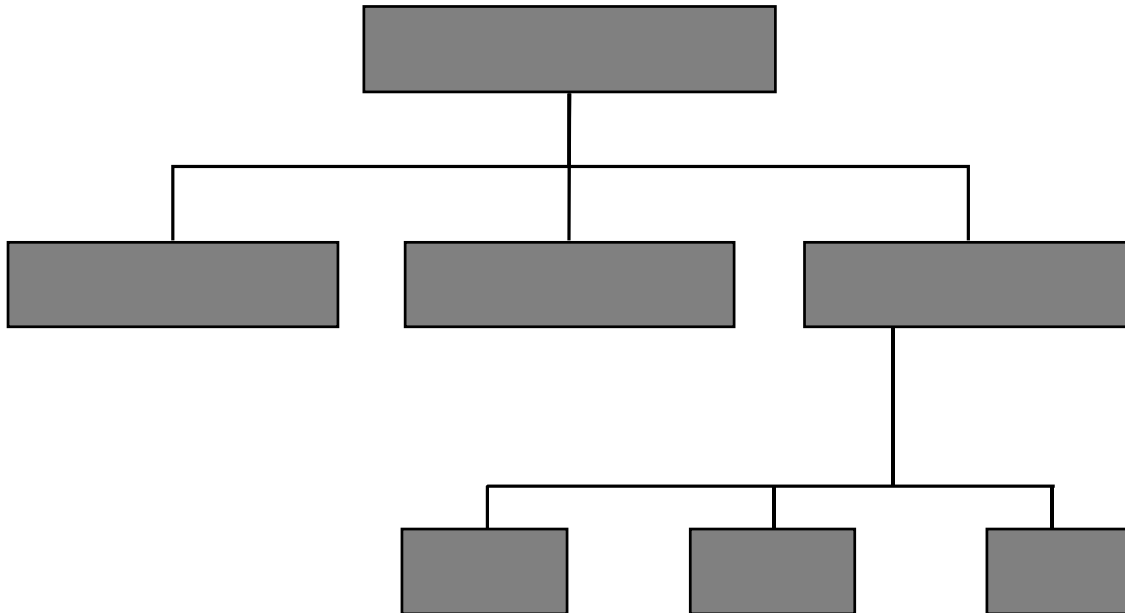

Some companies produce many similar products that have a lot of common parts. To reduce the workload for creating BOMs, you can extend a simple BOM to create a composite BOM, known as a "BOM group".

See also:

[Which Technical Types Exist? \[Page 37\]](#)

[When do I Create a Variant BOM? \[Page 38\]](#)

[When do I Create a Multiple BOM? \[Page 40\]](#)

Which Technical Types Exist?

The R/3 System supports two technical types of BOM to represent similar product variants and production alternatives:

- **Variant BOMs**

A variant BOM groups together several BOMs that describe **different** objects (for example, products) with a high proportion of identical parts.

A variant BOM describes the specific product variant for each product, with all its components and assemblies.

- **Multiple BOMs**

A multiple BOM groups together several BOMs that describe **one** object (for example, a product) with different combinations of materials for different processing methods.



The system does not define the technical type until you create either an additional alternative for a BOM or a different variant for an existing BOM.

If you already know which technical type you want when you create a BOM, you can define the technical type using a special function (see [Defining the Technical Type \[Page 240\]](#)).

When do I Create a Variant BOM?

When do I Create a Variant BOM?

The term "variant" refers to changes to the basic model of a product. These changes occur when components are left out or added.

If you are producing several similar products that have a lot of common parts, you can describe these products using a variant BOM. This is the case, for example, if you replace one material component with another to make a different product. Variants can also differ by containing different **quantities** of a component. You create the new BOM as a variant of an existing BOM.



You can only create a variant BOM from a simple material BOM. No multiple BOM can exist for the material.

A multiple BOM cannot be converted to a variant BOM.

The following graphic shows two products, which are represented by a variant BOM. The variant BOM contains components, which are only used in one of the variants, and one component, which is used in both variants.

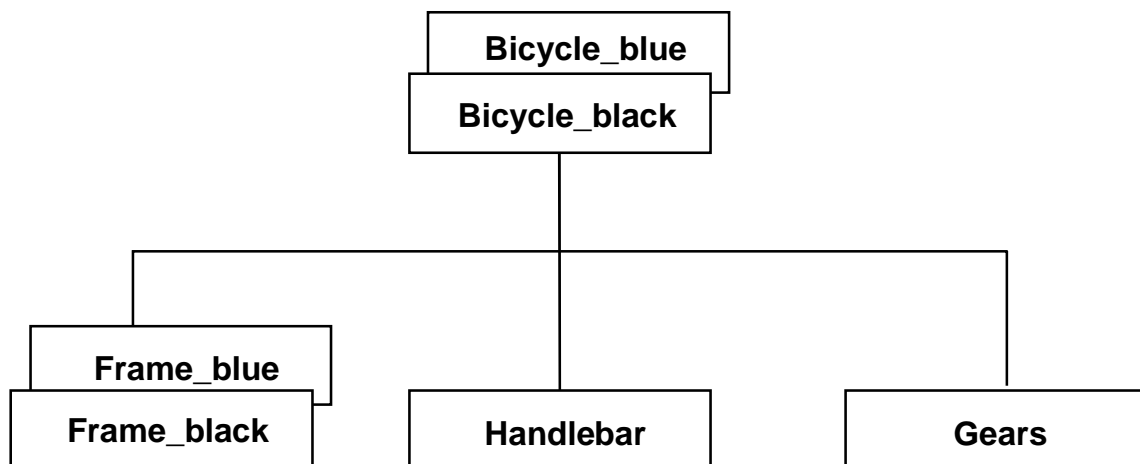

Variant BOMs are supported for the following BOM categories:

- Material BOMs
- Document structures
- Equipment BOMs
- Functional location BOMs



Several products that are created as variants of one variant BOM are stored as a BOM group under one internal BOM number.

You can enter a description to describe all the variants of a variant BOM. You enter this description in the *BOM group* (BOM header).

When do I Create a Variant BOM?

- As soon as you process one variant of a variant BOM, all the other variants are locked for processing.
- As soon as you process one variant using a change number, you must use a change number to process all the variants in the BOM group.

When do I Create a Multiple BOM?

When do I Create a Multiple BOM?

One product can be manufactured from alternative combinations of materials depending on the quantity to be produced (lot size). The product is represented by a number of alternative BOMs (alternatives). The differences between the alternative BOMs are only small. Usually the only difference is in the quantity of individual components.



Multiple BOMs are only supported for material BOMs.

The following graphic shows how a product is produced from different components or different quantities using different production procedures.

The multiple BOM contains components, which are only used in one of the alternatives, and one component, which is used in both alternatives.

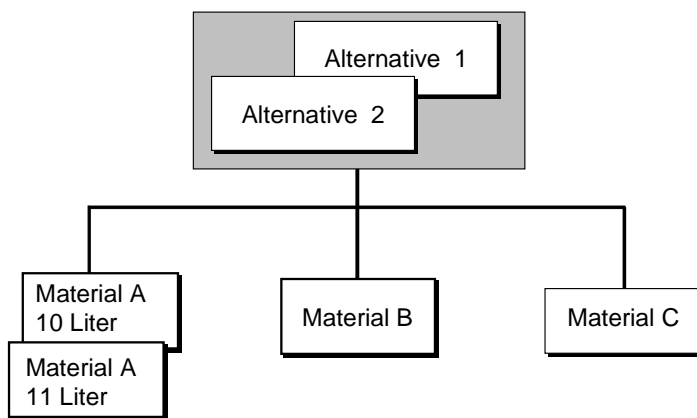

All alternatives of a multiple BOM are stored as a BOM group under one internal BOM number.

You can enter a description to describe all the alternatives of a multiple BOM. You enter this description in the *BOM group* (BOM header).

- As soon as you process one alternative in a multiple BOM, all the other alternatives are locked for processing.
- As soon as you process an alternative using a change number, you must use a change number to process all the alternatives in the BOM group.

BOM Usage

Many companies have only one universally applicable BOM structure for all areas of their company. This structure usually takes the form of complete single-level BOMs, created in the design department, and used in both material management and the assembly workshop.

The R/3 System allows you to maintain individual BOMs for any area of your company. These BOMs are maintained independently of each other and are assigned different internal BOM numbers. In this way, each area is only dealing with the specific data it requires.

In Customizing for *Production*, define individual BOM usages for the different areas within your company by choosing Basic data → Bill of Material → General data → BOM usage → *Define BOM usages*.

You can define BOM usages for the following scenarios:

- You maintain **separate** BOMs for different areas within your company, such as design or production.
- You create just **one** BOM for all areas within your company.

See also:

[BOM Usage as a Special View on a BOM \[Page 42\]](#)

[Defining the Item Status with the BOM Usage \[Page 44\]](#)

[BOM Usage and Material Type \[Page 46\]](#)

BOM Usage as a Special View on a BOM

BOM Usage as a Special View on a BOM

[Application as procedure for automatic alternative determination \[Page 370\]](#)

If you maintain separate BOMs for a product in different areas of your company, you can use BOM reporting functions to obtain information that is directly relevant to your requirements.



The *design BOM* includes all the components of the product and their technical data from the design point of view. This BOM is generally not linked to any order.

The *production BOM* includes all the items required from the production and assembly point of view. To assemble a product, you only require items that are relevant to production, which contain process data.

The *costing BOM* describes the product structure and is used to automatically determine the costs of the materials required for a product. Items that are not relevant to costing are not included in the costing BOM.

Each area (for example, production) creates its own BOM that contains application-specific data, instead of using one BOM for the entire company. Each area can target the BOM explosion to find only the data that is relevant. The data shown in a BOM explosion also depends on how the BOM *application* is defined. For example, a BOM application can define priorities for BOM usages.

The following graphic shows how different application areas in a company add their data to a BOM.

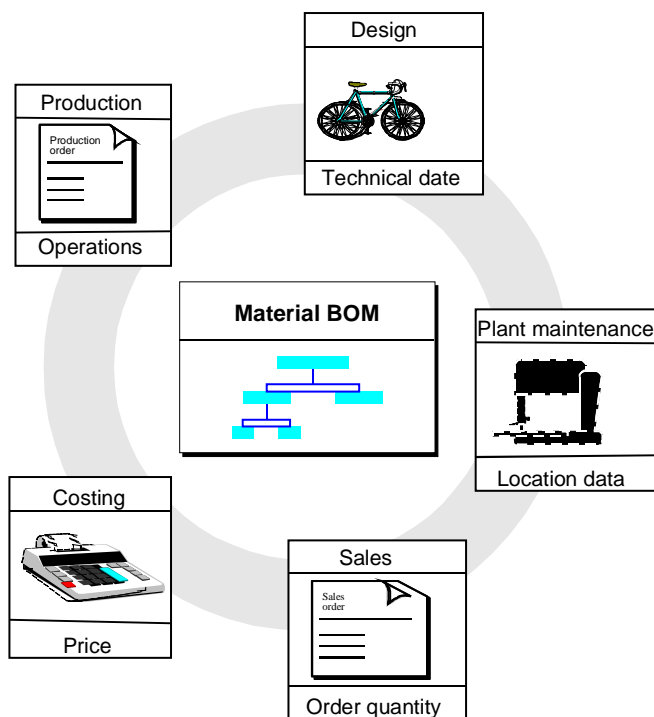

Defining the Item Status with the BOM Usage

Defining the Item Status with the BOM Usage

[Item status \[Page 194\]](#)

By defining the BOM usage (Customizing for *Bills of material*, step *Define BOM usages*), each company determines which item statuses can and cannot be set.

The *item status* covers a range of indicators that can be entered for BOM items, such as *relevant to engineering*, *relevant to production*, *relevant to costing*, and so on.

These item status indicators control:

- Processing of the BOM in related application areas.
The indicators define whether further processing is required, allowed, or not allowed. If processing in an application area is supported, you can maintain application-specific data for the items. For example, only items that are relevant to production are copied to a production order.

- The selection of items for BOM explosion

See also:

[Restricting the View for BOM Explosion \[Page 380\]](#)

Item Status Indicators

You can define indicators as *optional* fields for a BOM usage. This means that you can set these indicators for **one** item in a BOM and not for another item.

When you configure your R/3 System, you define application areas for which BOM items are relevant by using the following indicators:

- *Item relevant to production*
- *Item relevant to engineering*
- *Item relevant to plant maintenance*
- *Item relevant to sales and distribution*
- *Item relevant to costing*
- *Spare part*

See also:

Status/Long Text

Item Status Example

The following table shows an example of indicators set for the BOM usage *Design*.

Item statuses for BOM usage *Design*

Indicator	Maintenance
<i>Item relevant to engineering</i>	must be maintained

Item Status Example

<i>Item relevant to production</i> <i>Spare part</i>	can be maintained
<i>Item relevant to plant maintenance</i> <i>Item relevant to sales and distribution</i>	cannot be maintained



Before you can enter PM structure elements and items relevant to plant maintenance in functional location BOMs and equipment BOMs, you need to choose a BOM usage that supports plant maintenance items.

Each area (for example, production or design) maintains a separate BOM with a separate usage. If you create **several** BOMs for **one** material with different usages, the system saves each BOM usage under a separate internal BOM number. Authorizations for BOMs are defined per BOM usage.

BOM Usages for a Material: Example

The following graphic shows how BOMs with different usages are stored for one material (men's racing bicycle PP-MRB01).

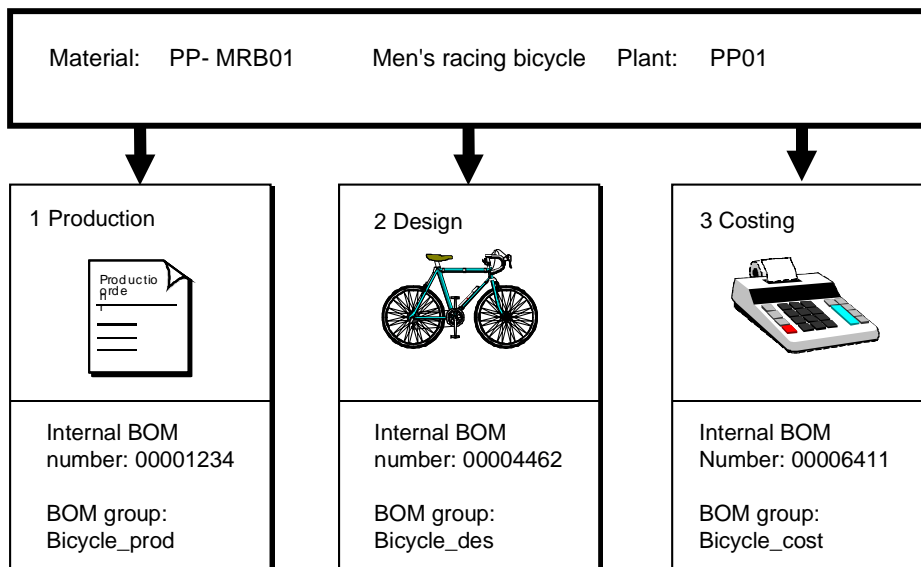

BOM Usage and Material Type

BOM Usage and Material Type

In Customizing for *Production*, you can define all the material types for which you can create a BOM for each BOM usage, by choosing *Bill of material* → *General data* → *Define allowed material types for BOM header*.

In the standard system, you can create a BOM for all material types. In the fields *BOM usg* and *Matl type*, the special character "*" is entered as a place holder for all possible BOM usages or material types.



In Customizing for *Production*, you can define the material types for which you can create BOMs of each usage in your company. In this case, specific field entries replace the generic entries supplied as standard, and the value in the *Allowed* column defines whether BOMs for this usage and material type are allowed or not allowed.

BOM Usage and Material Types: Example

If you want to create a material BOM for the BOM usage *Production*, you can do this if the material has material type **FERT** (finished product), but not if the material has material type **HIBE** (operating supplies). Operating supplies are procured externally and are required for producing other products.

The table entries for this example would look like this:

BOM Usage and Allowed Material Types

BOM usage	Material type for BOM header	Allowed
1 (<i>production</i>)	*	+
1 (<i>production</i>)	HIBE	-

First, the system checks the entries which are not generic (HIBE), then all generic entries (*).

Structure of a BOM

BOM data is structured as follows in the R/3 System:

- The **BOM header** contains data that applies to the entire BOM.
- The **BOM item** contains data that only applies to a specific component of the BOM.
- **Sub-items** contain data on the different installation points for partial quantities of an item.

Structure of a BOM

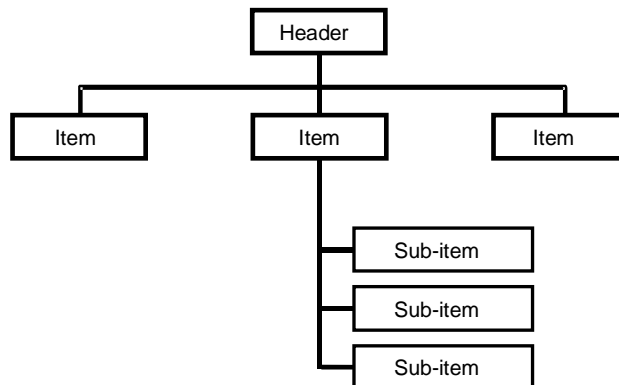

See also:

[BOM header \[Page 48\]](#)

[BOM item \[Page 58\]](#)

[Subitems \[Page 65\]](#)

BOM Header

BOM Header

In the BOM header, you maintain data that refers to the entire object:

- For a multiple BOM, this means one of the alternative BOMs for an object (for example, a product)
- For a variant BOM, this means one of the variants

This data is maintained on various header details screens. On each detail screen, you see the header data that identifies the BOM uniquely in the R/3 System.

See also:

[Data Used to Identify a BOM \[Page 49\]](#)

[Header Detail Screen: Quantity/Long Text \[Page 51\]](#)

[Header Detail Screen: Additional Data \[Page 54\]](#)

[Header Detail Screen: Administrative Data \[Page 55\]](#)

Data Used to Identify a BOM

This data is used, for example, to access a BOM. As this data uniquely identifies a BOM in the R/3 System, it is displayed on each header detail screen.

- **Material**

Number of the material for which you create, change, or display a BOM.

When you create a new BOM, the system also checks whether the material type is allowed for the BOM usage.
- **Plant**

Key which identifies the plant in which the BOM is valid.

If you create the BOM without reference to a plant, you create a group BOM. Under certain conditions, you can allocate the BOM to several plants.
- **Revision level**

Identifies the change status of a material.

The revision level can be uniquely assigned to changes made using a change number.
- **BOM**

Counter which is assigned internally by the system from within a defined number range. The combination of BOM category and this number is unique and identifies the BOM or BOM group.
- **Alternative**

Identifies a BOM within a BOM group (variant BOM, multiple BOM).

For example, several alternatives represent different processing methods for one product, which may result from different lot-size ranges (technical type: *multiple BOM*).
- **Usage**

Key which represents a specific area of the company (such as production or costing) in which the BOM is used.
- **Technical type**

The technical type distinguishes BOMs according to whether they represent product variants or production alternatives.

The system defines the BOM for a material as a:

 - *variant BOM*, if you create a variant of a BOM
 - *multiple BOM*, if you create several alternatives



There is also a special function for defining the technical type manually when you create the first alternative (technical type " ").
- **BOM group**

Data Used to Identify a BOM

Collective name for all BOMs in a group of BOMs, which allows you to describe one product or several similar products. The value in the *BOM group* field uniquely identifies the BOM group. You can use the BOM group as an alternative way of accessing the BOM.

A BOM group comprises either all the alternatives of a multiple BOM or all the variants of a variant BOM.

When you create a BOM group, the system checks the special characters you use. Apart from the usual alphanumeric characters, you can use the following special characters: "-", "/", "_". You cannot use blanks.



Header Detail Screen: Quantity/Long Text

This detail screen contains descriptive texts, quantity data, and validity data, grouped together in three datasets.

Texts Describing the BOM

You can enter the following texts:

- **BOM text:**
 - Short text describing the BOM or BOM group.
 - This text refers to all variants of a variant BOM or all alternatives of a multiple BOM.
- **Alternative text:**
 - Short text describing the individual variant of a variant BOM or alternative of a multiple BOM.
 - This text does not refer to the entire BOM group.

By clicking on  you can enter a long text for both text types. If a long text is available the system displays the symbol: . By clicking on this button you can change the long text.

Quantity Data for the Different Technical Types

The *Base quantity* is relevant to all BOMs. There is also a special quantity entry for multiple BOMs – the *Lot size*.

- **Base quantity**
 - All component quantities in a BOM refer to the base quantity. In Customizing for *Production*, you can define a default base quantity for creating BOMs by choosing *Bill of material* → *Control data for bills of material* → *Define default values*.
- **Base unit of measure**
 - All component quantity units in a BOM refer to the base quantity unit.
 - For material BOMs, the system determines this unit from the material master. You cannot change the unit, because stocks of the material are kept in this unit.
 - In Customizing for *Production*, you define a unit of measure for piece in the *Unit of measure 'piece'* field by choosing *Bill of material* → *Control data for bills of material* → *Define modification parameters*. This unit is the base unit of measure for the following BOM types:
 - Equipment BOMs
 - Functional location BOMs
 - Document structures
 - Standard BOMs
- **Lot size from/to**
 - These fields are only relevant to multiple BOMs.

Header Detail Screen: Quantity/Long Text

You can enter a **lot-size range** for each alternative. Components or component quantities in an assembly may vary according to the quantity to be produced or procured (the lot size).

The lot size is an essential factor for determining which alternative is to be used. For example, the alternative selection for the dependent requirements can take place via the lot size. During the planning run, the system finds the alternative that matches the lot size in the planned order and uses this alternative to determine dependent requirements.

Validity Data

The **Validity** dataset contains various data that restricts the processing of a BOM.

- **Change number**

Number of the change master record that controls the change to the material BOM.

The system uses the change master record to determine the valid-from date of the change. All changes are logged and can be documented in detail.

You can also assign a revision level to change statuses of a material and a document.

- **Valid-from date**

Start of validity period of the BOM in the standard R/3 System.

If you process a BOM using a change number in the standard R/3 System, the system uses the change master record to determine the valid-from date.

If you process the BOM with reference to a change number that has a new validity type (for example, validity by serial number), the system ignores valid-from date. The validity of the item depends on other values (for example, range of serial numbers).

- **BOM status**

The status is used to control BOM processing in the different application areas.

In Customizing for *Production*, you define the statuses for BOMs, using indicators that allow or prevent processing by choosing *Bills of material* → *General data* → *Define BOM status*. This indicator enables you to process BOMs in the selected areas of a company or to exclude them.



BOM A:

A BOM with status 1 can be exploded in material requirements planning (MRP) and released for a planned order.

BOM B:

A BOM with status 2 can neither be exploded in MRP nor released for a planned order.

- **Authorization group**

This key, which refers to an authorization value in the user profile, controls access to the entire BOM.

In addition to the authorization group, values for the *Activity*, *BOM usage*, and *BOM category* are defined in the user profile.

Provided that the values in these fields pass the system checks, the authorization group controls the check as follows:

Header Detail Screen: Quantity/Long Text

- If there is no entry, the authorization group of the user is not checked. Any user can access the BOM.
 - If there is an entry, only those users with the authorization group entered in their user master record can access the BOM.
 - If you want to assign an authorization group to the BOM, you can only enter an authorization group from within the range defined in your user profile.
- **Deletion indicator**

This indicator shows that the BOM is marked for deletion.

Before you can archive a BOM (archiving object CS_BOM), you must mark it for deletion. You can still process the BOM, but the BOM will be deleted during the next reorganization run.

See also:

[Archiving \[Page 123\]](#)

Header Detail Screen: Additional Data

On this detail screen, you enter data in the *Additional data* and *Material data* datasets.

General BOM Data

- **Laboratory/office**

In this field, you enter the **laboratory/design office** responsible for the product.

When you create the BOM, this value is copied from the material master record. You can update this value at any time.

- **CAD indicator**

The BOM automatically has this indicator set if it has been created or changed from a computer-aided design (CAD) system.

- **ALE Indicator**

With this indicator a BOM is flagged if it is distributed via the ALE into the SAP System.

Material Data

- **Size/dimension**

This field describes the dimension of the material. This is a text field and is for information only.

The value displayed in this field is taken from the material master record. You cannot change this value in a BOM processing function.

Header Detail Screen: Administrative Data

On this screen, the system displays the data that identifies the BOM. You also see the following validity data:

- Date BOM was created
- Name of user who created the BOM.
- Date BOM was last changed
- Name of user who last changed the BOM

You also see which change master record governs the next validity period of the BOM.

If you have created or changed BOM header data using a change number, the change master record you used is identified in the *Change number* field. If this change status has also been changed using a change number, you see the change number whose change master record controls and documents the next change in the *Change number to* field.

Document Assignments

Document Assignments

Use

This function enables you to assign one or more documents to a BOM item or a BOM header. In this way, you can quickly access documents and display the originals when you process a BOM.



If, for example, you assign the design drawing of the appropriate components to each item, when you process the BOM you can immediately view the drawing for the specific component.

Furthermore, the assignment of documents to BOM headers and items is a prerequisite for Digital Mock-Up Viewing.

Prerequisites

In Customizing the document management (*Define document type* → [Determine object link \[Ext.\]](#)), you define with which BOM headers and items the document type can be linked.

See also:

[Object Links \[Ext.\]](#)

Features

You can assign a document to a BOM header or item. On the header detail screen and the item detail screen of each item there is a tab page with a list of the assigned documents. In this list, you can:

- Assign documents
- Delete document assignments
- Look for documents
- Sort the list in ascending or descending order
- Go to document info records
- Display and print out original documents
- Add notes

Digital Mock-Up Viewing

Document assignment is a prerequisite for Digital Mock-Up Viewing. If you want to view the 3D model of an assembly in the Engineering Workbench, document info records for the 3D models of the appropriate components have to be assigned to the BOM items. If you work with the CAD interface and you have set the parameters for Digital Mock-Up Viewing, the system automatically carries out the assignments.

See also:

[Digital Mock-Up Viewing \[Ext.\]](#)

Constraints

Document assignment is only supported for material BOMs and order BOMs.

Activities

You can assign a document to a BOM header or item:

You are in the header detail screen or in an item detail screen of a material BOM.

1. Choose the *Document assignment* tab page.
2. On an empty line, enter the document type and the document number as well as the document part ID and version number.
3. Save.

BOM Items

BOM Items

BOM items are the component parts of a product. Item data applies to only one actual item in a BOM.

Some data has to be entered for all item categories as soon as you create an item. Other specific data can be completed in the application areas (such as design and purchasing) for all item categories.

This section describes the data required for creating items of all item categories. The data which is dependent on item category is described in detail in [Item Detail Screens \[Page 138\]](#).

See also:

[Item Data Relevant to All Items \[Page 59\]](#)

[Item Data Relevant to Material Items \[Page 61\]](#)

[Item Data Relevant to Document Items \[Page 62\]](#)

[Item Data Relevant to Class Items \[Page 63\]](#)

Item Data Relevant to All Items

The following section describes the fields in which you make entries for all the items in a BOM. It also describes the item data determined by the system.

- **Item number**

This number is used to sort an item within the BOM. You can sort the items in ascending order of item numbers.

In Customizing for *Production*, you can define a value by which the item number is increased (for example, 0010, 0020, 0030, and so on) by choosing *Bill of material* → *Define user-specific settings*.

- **Component**

To identify the objects you are entering as components of a BOM, you enter certain data from the object master record. For more detailed information, see the specific topics on material items, document items, and class items.

- **Component description**

If the component has a master record (for example, a material master record), this description is taken from the master record.

- **Component quantity**

In this field, you enter the quantity of the component required to make the base quantity of the product. You must enter a component quantity.

- **Unit of measure**

This field shows the unit of measure for the component quantity. For more detailed information, see the specific topics on material items, document items, and class items.

In Customizing for *Production*, you define a unit of measure for *piece* in the *Unit of measure 'piece'* field by choosing *Bill of material* → *Control data* for bills of material → *Define modification parameters*. This unit is the base unit of measure for the following item categories:

- Text item
- Document item
- Non-stock item without a material master

- **Item category**

When you create each new BOM item, you must assign the item to an item category. This field is defined as a required field on all screens for entering items. The item category defines data entry and processing for an item.

- **Item IDs**

A BOM item is uniquely identified by its item ID.

The system makes the following checks:

- Change number, *Valid from* date, *Valid to* date

Item Data Relevant to All Items

The system sets this validity data automatically. This data shows the validity period of the item within this BOM.

- **Assembly**

If the component has its own BOM, the system sets this indicator.

- **Sub-Items**

If the item has sub-items, the system sets this indicator.

Item Data Relevant to Material Items

In the R/3 System, items in a material BOM tend to be material components. You use material numbers to identify these components.

See also:

[Item Categories for Material Items \[Page 127\]](#)

The following data is relevant to material items:

- **Component**

The system checks the material master in the plant in which you are maintaining the BOM. The system does not check plant data for a group BOM.

In certain situations, you do not need to enter a material number. For example, you can create a non-stock item without entering a material number.

- **Component unit of measure**

- For material components, you can maintain alternative units to the base unit of measure in the material master record.

In *Bills of material*, not all of these alternative units of measure are used. Only the unit of issue is relevant.

Possible values for the component unit of measure are therefore:

- Base unit of measure
- Unit of issue
- Units of measure that can be converted to the base unit of measure or unit of issue (same dimension)
- If you do **not** enter a unit, the system proposes a unit from the material master record, if the item has a material master record. If a unit of issue is entered on the storage detail screen of the material master, the system copies this unit to the BOM. Otherwise, the system copies the base unit of measure to the BOM.
- Units of measure without a dimension are only supported if they are identical to the stockkeeping unit or the unit of issue. You can define alternative units of measure in the material master.
- For non-stock items without a material master record, the system sets the value **piece** (PC).



In Customizing for *Production*, you can define which material types for BOM items can be combined with which material types for the BOM header and BOM usage in your company by choosing *Bill of Material* → *Item data* → *Define allowed material types for BOM items*.

Item Data Relevant to Document Items

Item Data Relevant to Document Items

You can enter document items. The document key data (document number, document type, document part, and document version) identifies the document.

See also:

[Document Items \[Page 133\]](#)

The following data is relevant to document items.

- **Document number**
You use this number to identify the document.
- **Document type**
You use this key to assign a document to a group of similar documents. These documents have the same distinguishing features, and are processed in the same way.
- **Document part**
You can divide larger documents into document parts. For example, design departments use document parts to divide large design drawings into several pages.
- **Version**
The version represents a change status or a status for delivery of a document. Version management is used to save different processing statuses of a document.
- **Item category**
When you enter document items, use the item category *Document item*.
- **Unit of measure**
The system automatically sets the value **piece** (PC) for a document item.

Item Data Relevant to Class Items

In configurable BOMs, you can create class items, which are identified by the class type and the class.

See also:

[Class Items \[Page 134\]](#)

The following data is relevant to class items.

- **Class type**

The class type has basic control functions for classes. For example, the class type determines which object types you can classify in a class (for example, class type 017 – documents).

- **Class**

A class is used to group together a number of similar objects (such as documents). These objects are described by means of characteristics which they have in common (for example, format and size).



In the additional data in class maintenance, there are several fields for controlling the use of a class in BOMs.

- **Unit of measure**

If the class type is linked to the document info record, the system sets the value **piece** (PC). Otherwise it sets the unit of measure from the class as a default value. This unit was entered in the *Base unit of measure* field in the additional data dataset. You can replace it with any unit of the same dimension.

- **Item category**

You enter classes as items using the item category *Class item*.

- **Resulting item category**

Before you can assemble a product whose BOM contains class items (for example, **Bolts**), each class item must be replaced by an object that is classified in the class during configuration.

When you create a class items, you must select an item category for the objects classified in the class (for example, material **A-B-0101**), in addition to the item category *Class item*. This second item category is known as the resulting item category. The resulting item category allows you to enter item-specific data when you create a class item.



If the class item contains a class for classifying materials, you can choose one of the following as a resulting item category:

- Stock item
- Non-stock item

Item Data Relevant to Class Items

- Variable-size item
- PM structure element

You can define a default value for the resulting item category for each class.

Sub-Items

Partial quantities of a BOM item may be installed at different points. Sub-items are used to describe the different installation points of these partial quantities.

- In Customizing for *Production*, you define for each item category whether sub-items are supported by choosing *Bill of material* → *Item Data* → *Define item categories*. For example, in the standard system, sub-items are supported for *Stock items* and *Variable-size items*.
- In the standard system, changes to sub-item data are **not** recorded by engineering change management.

In Customizing for bills of material, under *Define modification parameters*, you can define whether the old change state of a sub-item is retained after you change the sub-item. If at least one values of the sub-item is changed with changed effectivity parameters, the system creates a new item record for the new change state.

- You can maintain the sub-item quantity and a description for each sub-item.



Sub-items have **no** operational function in the BOM. They are not copied to the production order. However, you can use sub-items to help you create programs for your company (for example, automatic assembly programs).



In the production of printed circuit boards, the resistors of a printed circuit are installed in different positions. Information on the installation point, precise coordinates, installation method, and instructions for the automatic assembly machines is stored as independent programs.

Material BOM Browser

Material BOM Browser

Definition

Navigation tool for displaying the multi-level BOM of a material

Use

You use the material BOM browser to navigate in a multi-level material BOM.

Structure

In the material BOM browser, the multi-level BOM is displayed similarly to in the [product structure browser \[Ext.\]](#). This means you see an overview tree, whose branches you can show and hide. As opposed to the product structure browser, in the overview tree of the material BOM browser, only the BOM headers and items are displayed.

Navigation in the Material BOM Browser

Use





You use the material BOM browser to navigate in a multi-level material BOM.

Features

Object-specific Functions

You call up the object-specific functions using the icons in the overview tree as well as using the context menu.

Icons in the Overview Tree

Icon	Meaning	What you ought to know
	BOM Header	By clicking on the right mouse button, you display the context menu with the display and processing functions.
	BOM Items	
	Item in an assembly	
	Original available (document item only)	By clicking on the icon, you display the original file. You can find further information under Integrated Viewer for Displaying Original Application Files [Ext.] .

Display Functions

- Expand all
- Display (item overview or item detail screen)
- Expand in the new window of the product structure browser
- Multi-level BOM display (Multi-level BOM)

Processing Functions

- Change
- Change with change number
- Process in the Engineering Workbench

Additional Functions



- Send
- Store in the object folder

General Functions

You call up functions for the entire multi-level BOM in the application toolbar.

Navigation in the Material BOM Browser

Icons in the application toolbar

Icon	Function	Description
	Find	Displays a dialog box when you look for materials, documents and classes in the overview tree. The system automatically expands the subtree, in which the desired object is found, and highlights it.
	Display variant	Displays a dialog box, in which you can determine which information is displayed in the overview screen.
	Update	Re-explodes the BOM and updates the display in the overview tree.

Activities

Choose *Logistics* → *Production* → *Master Data* → *Bills of Material* → *Bill of material* → *Material BOM* → *Multi-level* → *Material BOM browser*.

Calling up the Browser

1. From the SAP Easy Access menu, choose *Logistics* → *Production* → *Master data* → *Bills of material* → *Bill of material* → <BOM type> → *Multi-level* → *Browser*.

You see the initial screen of the browser.

2. Enter the identified data for the BOM, the BOM application and also a date or a change number.

If you enter a change number here, the system uses this change number to explode the multi-level BOM in the overview tree. The change number on the initial screen of the browser is **not** valid for changes that you then carry out to the single-level BOM.



If you click  the system displays a list of the last ten BOMs displayed in the browser.



If you now click  the system displays other data from the environment of the selected BOM on the initial screen.

3. If you are working with large BOMs and only want to display the assembly on the top level of the multi-level BOM, enter a value for the maximum explosion level.
4. Click on  to enter the settings for explosion and display. You can
 - Define the view. For more information, see the component *PS – Project System* under [Define view for BOM explosion \[Page 377\]](#).
 - Restrict the view.
 - Using the indicator *Ltd Explosion* (Limited Explosion) you can select whether BOM items kept in stock should be exploded further. For more information, see the component *PP - BOMs* under [Restrict view for BOM explosion \[Page 380\]](#).
 - Using the indicator *Var. Display Depth* (Variable Display Depth) you can specify that only a section of the multi-level BOM is displayed in the order browser. You can find further information in [Variable display depth \[Page 71\]](#).
 - Specify whether the multi-level BOM should be automatically up-dated after each processing step.
 - Select whether the overview tree and the processing functions are displayed in the same window.

If you do this, the overview tree is displayed in the left or top screen area. If in the context menu of a BOM header or of a BOM item you select a processing function, the system displays this function in the right or bottom screen area.



Before you switch to another processing function remember to save, or click .

5. Click .

Calling up the Browser

Variable Display Depth

Use

In the design, you do not usually process the entire multi-level BOM for a sales order item but rather you concentrate on a specific assembly. You often do not want to display the entire multi-level BOM for a sales order item in the overview tree of the order browser, rather only the subtree for the assembly you want to process.

Prerequisites

You have set the *Variable disp. depth* (Variable display depth) indicator in the dialog box *Order browser: Settings*.

Features

When you call up the order browser, the *Display Depth* dialog box appears. There, you select the material number of the assembly at the head of the subtree that you want to display.

If you want to display another subtree at a later date, click on , to go back to the *Display Depth* dialog box.

The following functions are available in the *Display Depth* dialog box:

Function	Procedure	Notes
Display subtree	Enter the material number for the assembly at the head of the subtree. Use the possible entries function to do this, if necessary.	If an assembly in the multi-level BOM is used on various different nodes, you can clearly identify a node using the information on levels and nodes in the entry help.
Displaying the whole multi-level BOM	Deselect the <i>Retain Variable disp. depth</i> indicator.	This results in the <i>Display Depth</i> dialog box no longer being displayed during the current session.



In the initial node the system displays the material for the sales order item in all processing situations. This is also the case when you only display a subtree.

Activities

Activating Variable Display Depth

You activate variable display depth as follows:

You are in the initial screen of the browser.

1. Click .
2. The *Settings* dialog box appears.
3. Set the *Variable disp. depth* indicator.

Variable Display Depth

4. Click .

Enhancements to the SAP Systems in the Area of PLM

Purpose

You can optimize your work processes in the area of [Product Lifecycle Management \[Ext.\]](#) (PLM) by changing and enhancing the scope of functions the standard SAP System. The enhancements are part of the standard SAP System and can be set up in your SAP System by means of enterprise-specific logic.

Enhancements

The following is an overview of the supported enhancements in the area of PDM.

Enhancement	Note
<p>Customer exit</p> <p>See also: Customer Exits [Ext.]</p>	<p>Use</p> <p>The function process of the standard SAP System is done by means of customer exit within the SAP System enhancement concept. The exits provided with the system do not have any functionality of their own. They simply represent a starting point for additional document distribution functions which you can develop using company-specific logic.</p> <p>Integration</p> <p>The customer exits are programmed as function module exits. You create an enhancement project by editing an enhancement that SAP has supplied. The enhancement contains the function module for the required function. The function module leads to an include program where you encode the enterprise-specific function requirements.</p> <p>Prerequisites</p> <p>When you use a function exit, you must create a company-specific include program that matches the programming logic of the function module. For example, the data that can be transferred from the include program to the standard program, and vice versa, is predefined here. Since each call for a customer-specific function module used contains both export and import parameters, the customer-specific function modules are also equipped with this predefined interface.</p>

Enhancements to the SAP Systems in the Area of PLM

Business Add-In [Ext.]	<p>Use</p> <p>Business Add-Ins are defined parts within a source that can add coding for different software levels, such as branches, partners, or customers, without changing the original program itself. The coding of the standard SAP System allows you to add implementation where the methods for the enterprise-specific processing are set.</p> <p>Integration</p> <p>The coding of the standard SAP System contains the definitions of the interfaces as well as the calls for the application programs. This enhancement is made of an interface and a method.</p> <p>Each Business Add-in is made up of various methods that can be called in preset processing situations. The methods set the operations for the documents or their original application files. The enterprise-specific coding is entered in <i>Implementation</i>.</p> <p>Prerequisites</p> <p>You must enter the enterprise-specific enhancements in an implementation. You must create an implementation for the Business Add-In you have chosen and enter the required coding for the method. After the implementation is active you can use it when executing the application program.</p>
<p>Business Transaction Events</p> <p>See also:</p> <p>Using Business Transaction Events [Ext.]</p>	<p>You can use two types of interfaces for modifying and enhancing the standard SAP System:</p> <ul style="list-style-type: none"> • Publish & Subscribe interface (informative interfaces) The interface informs that a particular result has been produced and transfers the data to external software. • Process interface (Process) This interface replaces the standard processes from the SAP System.
<p>User exits in Customizing</p>	<p>You determine in Customizing of the application which enterprise-specific changes you want to carry out. You will find detailed notes in the IMG.</p>



Use the ABAP Workbench for the customer exits as well as for business add ins. Modification to SAP sources and ABAP Dictionary Objects are done within SAP Software Change Registration (SSCR).

These changes are upward compatible. This means that they remain effective even after an upgrade or installation of a support package.

Enhancements for Objects from the Area of PDM

The following overview shows which enhancements are supported for which SAP objects.

SAP Object	Customer exit	Business Add-In	Business Transaction Events	User Exits

Enhancements to the SAP Systems in the Area of PLM

Document [Page 76]	X	X		X
Material [Page 109]	X		X	
Change master record [Page 111]	X			
Bills of Material [Page 113]	X		X	

Enhancements in Document Management

Enhancements in Document Management

Use

You can set up work processes in the area of *Document Management* with different enhancements at an enterprise level.



Information about enhancements as well as an overview of planned enhancements to SAP objects in the area of PDM can be found in [Enhancements to the SAP System in the Area of PDM \[Page 73\]](#).

Features

The following overview shows which enhancements are supported in the standard SAP System in the area of DMS.

Enhancement	Use
Enhancements using Customer Exits [Page 77] See also: Customer exit [Ext.]	You can set up Document <i>distribution</i> using customer exits in an enterprise-specific way.
Enhancements using Business Add-Ins [Page 94] See also: Business Add-In [Ext.]	The coding of the standard SAP System allows you to add more than one implementation where the methods for the enterprise-specific processing of document info record and original application files are set.
Enhancements using User Exits in Customizing [Page 107]	You determine in Customizing of the Document Management which enterprise-specific changes you want to carry out. You will find detailed notes in the IMG.

Enhancements using Customer Exits (Document)

Use

In order to optimize the business processes in document management you can change some functions of the SAP System by using [Customer Exits \[Ext.\]](#). You can, for example, add additional authorization checks.

See also:

[Enhancements of the SAP System in the Area of PDM \[Page 73\]](#) and [The SAP System Enhancement Concept \[Ext.\]](#)

Prerequisites

When you use a function exit, you must create a company-specific include program that matches the programming logic of the function module.



You want to determine the original application files for a distribution order. You create an enhancement project where you use the enhancement CVDI0003 (*Determine original application files*). The enhancement contains the function module for the required function (for example, EXIT_SAPLCVV1_003). The function module branches to the include program zxcvv5u02. You use this include program to program your specific functional requirements.

Features

The tables below show the enhancements for customer exits used in document distribution (development class CVDI).

Enhancements for Function Group XCVV1 (Recipient List)

Use	Enhancement	Function Module
Save recipient list	CVDI0001	EXIT_SAPLCVV1_001 [Page 79]
Modify initial values for screen 100	CVDI0002	EXIT_SAPLCVV1_002 [Page 81]
Determine original application file	CVDI0003	EXIT_SAPLCVV1_003 [Page 84]
Determine document part and version of a document	CVDI0004	EXIT_SAPLCVV1_004 [Page 86]
Create distribution order	CVDI0005	EXIT_SAPLCVV2_001

Enhancements for Function Group XCVV2 (Distribution Order)

Use	Enhancement	Function Module
Create distribution order	CVDI0005	EXIT_SAPLCVV2_001 [Page 86]

Enhancements using Customer Exits (Document)

Check part order	CVDI0006	EXIT_SAPLCVV2_002 [Page 87]
Create initial order	CVDI0007	EXIT_SAPLCVV2_003 [Page 88]

Enhancements for Function Group XCVV5 (Events)

Use	Enhancement	Function Module
Determine context	CVDI0008	EXIT_SAPLCVV5_001 [Page 90]

Enhancements for Function Group XCVVW (ITS Access)

Use	Enhancement	Function Module
ITS access	CVDI0009	EXIT_SAPLCVVW_001 [Page 92]

Finding Recipient Lists (EXIT_SAPLCVV1_001)

Definition

Function module that is called by customer exit CVDI0001 when a recipient list is saved and **before** the data is written to the database.

Use

You cannot change the program logic. You can only change the data in the logic.

Structure

The interface is structured as follows:

Parameters that can be processed in the Function Module

	Parameter	Parameter value Result	Direction	Description
importing	i_action	I	→	Create a recipient list
		U	→	Change a recipient list
exporting	e_return	0	←	OK
		<>0	←	Error
changing	c_drzao		↔	As database structure DRZAO (general data in a recipient list)

Tables Whose Fields can be Processed in the Function Module

Table	Description
T_DRZA	As database structure CVIDRZA (recipient-document relations)
T_DRZAT	As database structure CVIDRZAT (language-dependent description)

Integration

You can enter your company-specific programming logic in the source code of include program zxcvv1u01.

Screen: Basic Data for Maintaining Documents

Screen: Basic Data for Maintaining Documents

Definition

Function module that is called by customer exit CV110001.

Use

You can add to and enhancement the dialog for maintaining document data (function module in development class CV, function group CV110).

Integration

You can enter your company-specific programming logic in the source code of include program ZXCV110U01.

Screen: Recipient Lists (EXIT_SAPLCVV1_002)

Definition

Function module that is called by customer exit CVDI0002 **after** the data for recipient list screen (screen 100, program `SAPLCVV1`) has been read.

Use

Depending on the function (`i_function`) called, documents, recipients, or general data is determined. You can change this data in the include program. The modified data is then displayed on screen 100 (program `SAPLCVV1`).

If you change recipient data, for example, the changes must also be made in the following tables:

- Table T_DRZA (document recipient relation)
- Table T_REC (to display the change in the table control)

Structure

The interface is structured as follows:

Parameters that can be processed in the Function Module

	Parameter	Parameter value	Direction	Description
exporting	e_return	0 <>0	←	OK Error

Screen: Recipient Lists (EXIT_SAPLCVV1_002)

importing	i_function	CR	→	Create recipient list
		CH		Change recipient list
		DI		Display recipient list
		RD		Display all recipients of a document
		DR		Display all documents sent to a recipient
		SC		Display Start distribution with Recipient Lists
		SW		Start distribution with dialog
		SN		Start distribution without dialog
		SR		Start distribution without reading existing recipient list
		ST		Start distribution with standard recipient list
		RE		Restart distribution with dialog
		RP		Restart distribution of a package with dialog
		i_ass_id		Number of the recipient list
i_ref_ass_id	Number of the template for Recipient Lists			

Tables Whose Fields can be Processed in the Function Module

Table	Description
T_DRZA	As database structure CVIDRZA (document/recipient relation)
T_DOC	As database structure CVIDOC_TAB (documents displayed in the table control)
T_REC	As database structure CVIREC_TAB (recipients displayed in the table control)
T_IMP_OBJ	As database structure CVDIOBJ (table with selected document that was used to start the function)

Screen: Recipient Lists (EXIT_SAPLCVV1_002)

T_TEXT	As database structure CVITEXT (language-dependent description of the recipient list) - for recipient list functions only
--------	--

Integration

You can enter your company-specific programming logic in the source code of include program zxcvv1u02.

Determine Original Application File (EXIT_SAPLCVV1_003)

Determine Original Application File (EXIT_SAPLCVV1_003)

Definition

Function module that is called by customer exit CVDI0003 to determine the original application file that is to be sent.

Use

If the file is to be distributed manually (in dialog mode), this value is a default value and can be overwritten.

Structure

The interface is structured as follows:

Parameters that can be processed in the Function Module

	Parameter	Parameter value	Direction	Description
exporting	e_return	0 <>0	←	OK Error

Document Part and Version (EXIT_SAPLCVV1_004)

Document Part and Version (EXIT_SAPLCVV1_004)**Definition**

Function module that is called by customer exit CVDI0004. This function module is used to determine the key fields “document part” and “version” for the document to be distributed.

The customer exit is called when distribution is started for the recipient list (transaction CV17).

Use

The last version released is determined and proposed as a default for all documents in the recipient list. To determine a different version, enter your own logic for determining the version in the include.

Structure

The interface is structured as follows:

Parameters that can be processed in the Function Module

	Parameter	Parameter value Result	Direction	Description
importing	e_doktl e_dokvr e_return	0 <>0	→	Document part Document version OK Error
exporting	i_doknr i_dokar		←	Document number Document Type

Integration

You can enter your company-specific programming logic in the source code of include program zxcvv1u04.

Create Distribution Order (EXIT_SAPLCVV2_001)

Definition

Function module that is called by customer exit CVDI0005.

This customer exit is checked in the `create` method of BOR object BUS1082 (function module `CVV2_DDO_CREATE` – create distribution order). The exit is called after an initial order has been created and the INITIATED event has been generated.

Use

The distribution order parameters can be modified in the include. Individual part orders that are not relevant for distribution can be deleted from the table. Status *IG* or *ER* must be set in the customer exit for these part orders. You can use function module `CVV3_DDOC_SET_READY` (set part order status) for this purpose.

Structure

The interface is structured as follows:

Parameters that can be processed in the Function Module

	Parameter	Parameter value	Direction	Description
exporting	e_return	0 <>0	←	OK Error
changing	c_drzo		↔	As database structure DRZO (distribution order data)

Tables Whose Fields can be Processed in the Function Module

Table	Description
T_DDOC	List of part order numbers (structure: CVIORDERCOMP)

Integration

You can enter your company-specific programming logic in the source code of include program `zxcvv2u01`.

Check Part Order (EXIT_SAPLCVV2_002)

Check Part Order (EXIT_SAPLCVV2_002)

Definition

Function module that is called by customer exit CVDI0006.

This customer exit is checked in the `check` method of BOR object BUS1082 (function module CVV2_DDO_CHECK – check distribution order). The exit is called after an initial order has been created and the INITIATED event has been generated.

Use

The status of the part order is set to ER (error) if the `e_return` parameter returns a value $\neq 0$. A special process is implemented in the workflow for part orders that contain errors.

Structure

The interface is structured as follows:

Parameters that can be processed in the Function Module

	Parameter	Parameter value	Direction	Description
exporting	e_return	0 <>0	←	OK Order part has errors, do not distribute
importing	ddoc_id		→	Part order number

Integration

You can enter your company-specific programming logic in the source code of include program `zxcvv2u02`.

Create Initial Order (EXIT_SAPLCVV2_003)

Definition

Function module that is called by customer exit CVDI0007 when the system creates an initial order.

Use

The initial order data and part order data can be modified. You can also specify a status to be set for the part orders. If an error occurs in this customer exit, it must be output with the following statement: `MASSEGE ID id TYPE mtype NUMBER n raising ERROR.`

Structure

The interface is structured as follows:

Tables whose Data can be Changed (Changing)

changing	Description
c_drzoi	Initial order data (structure DRZOI)
c_status	Status SY - start immediately AS - start in the background MA - start manually in distribution log

Tables Whose Fields can be Processed in the Function Module

Table	Description
T_DRZOC	Part orders (structure: DRZOC)

Interface Parameters for Exceptions

Parameter	Description
ERROR	Error situation

Integration

You can enter your company-specific programming logic in the source code of include program `zxcvv2u03`.

Determine Context (EXIT_SAPLCVV5_001)

Determine Context (EXIT_SAPLCVV5_001)**Definition**

Function module that is called by customer exit CVDI008 if distribution is started by an event.

Use

The context that is to be used for distribution can be determined here. You can specify a context for an event in Customizing for Document Distribution. If other contexts are also to be included for this event, you must use this customer exit.

The function module is called in the following function modules:

- CVV5_EVENT_START_DISTRIBUTION (start distribution – initiated by an event)
- CVV5_EVENT_START_DIST_ECM (start distribution when change master record event is released)

Structure

The interface is structured as follows:

Parameters that can be processed in the Function Module

	Parameter	Parameter value	Direction	Description
exporting	e_return	0 <>0	←	OK Error
importing	i_event i_objkey l_objtype		→	Event (such as SWEINSTOU-EVENT) Object key (such as SWEINSTOU-OBJKEY) Object type (such as SWEINSTOU-OBJTYPE)
changing	c_context			Context

Tables Whose Fields can be Processed in the Function Module

Table	Description
T_EVENT_CONTAINER	Event container (structure SWCONT)

Integration

You can enter your company-specific programming logic in the source code of include program zxcvv5u02.

ITS Access (EXIT_SAPLCVVW_001)

ITS Access (EXIT_SAPLCVVW_001)**Definition**

Function module that is called by customer exit CVDI0009 if the original application file is to be accessed via the Internet Application Server (ITS).

Use

Additional authorizations, for example, can be checked in this customer exit.

The exit is called in function module CVVW_GET_ORIGINAL (read original application file from application server).

Structure

The interface is structured as follows:

Parameters that can be processed in the Function Module

	Parameter	Direction	Description
importing	e_doknr	→	Document number
	i_dokar		Document Type
	i_doktl		Document part
	i_dokvr		Document version
	i_filename		File name on application server
	i_ddoc_id		Part order number
	i_application		Workstation application

Interface Parameters for Exceptions

Parameter	Description
ERROR	Error situation

Integration

You can enter your company-specific programming logic in the source code of include program zxcvvwu01.

Determining the Application (EXIT_SAPLCVV1_005)

Definition

Function module that is called by customer exit CVDI0010.

Use

You can determine which workstation application was used to process the original application files that are to be distributed with this function module.

Enhancements using Business Add-Ins (Document)

Enhancements using Business Add-Ins (Document)

Use

In order to optimize processes in your enterprise when working with document processing you can use Business Add-Ins to enhance the processing functions of the standard system.

See also:

[Enhancements of the SAP System in the Area of PDM \[Page 73\]](#) and [Business Add-Ins \[Ext.\]](#)

Integration

The coding of the standard SAP System contains the definitions of the interfaces as well as the calls for the application programs. This enhancement is made of an interface and a method.



You can use a Business Add-In to set that when a workstation application is started that compressed original application files are reproduced.

Prerequisites

You must create an implementation for the Business Add-In you have chosen and enter the required coding for the method.

Features

The following overview shows the Business Add-Ins that are supported in the Document Management System (development class CV).

Business Add-Ins for the Document Management System

Description	Business Add-In
Checking Authorization from the Document Management Systems	DOCUMENT_AUTH01 [Page 96]
Processing of Original Application Files	DOCUMENT_FILES01 [Page 97]
General document processing	DOCUMENT_MAIN01 [Page 99]
Status checks	DOCUMENT_STATUS01 [Page 101]
Transport of Original Application Files	DOCUMENT_STORAGE01 [Page 102]

Business Add-In without the Documentation in the SAP Library

The following Business Add-Ins were added to the notes 02200177:

Description	Business Add-In
Document exits and Menu enhancements for PAI in CV01N, CV02N, CV03N	DOCUMENT_MAN02
Enhanced number checks	DOCUMENT_NUMBER01
Filter for DMS processes	DOCUMENT_PROC01

Enhancements using Business Add-Ins (Document)

Enhancements for the DMS@Web scenarios	DOCUMENT_WEB01
Enhancements for Microsoft Office integration	DOCUMENT_OFFINTEGR01

Checking Authorization from the Document Management Systems

Checking Authorization from the Document Management Systems

Definition

Interface for an enhancement that the customer can use to extend the authorization check of the standard SAP System to include enterprise-specific authorization checks.

Use

You program the enterprise-specific authorization checks for the method of the Business Add-In.

Structure

The interface of the Business Add-In includes the following method:

Method	Call	Example of a special check
CHECK_AUTHORITY	After checking the authorization of the following authorization objects: C_DRAW_TCD C_DRAW_TCS C_DRAW_DOK	Enterprise-specific logic when deleting

Integration

You implement the enhancement by using Business Add-In DOCUMENT_AUTH01.

Processing of Original Application Files

Definition

Interface for an extension where the customer's enterprise-specific requirements for processing original application files are implemented.

Use

You can use one or more methods for implementing the interface. You program the enterprise-specific requirements for the method of the Business Add-In.

Structure

The interface of the Business Add-In includes the following method:

Method	Call	Example of a special check
BEFORE_ASSIGN_FILE	Before the assignment of a physical file (original application file)	<ul style="list-style-type: none"> Automatic definition of an original application file Enterprise-specific checks
AFTER_ASSIGN_FILE	After the assignment of a physical file (original application file)	Check whether the original application file is valid
BEFORE_START_APPL	Before starting the application	Reproduces compressed files
AFTER_START_APPL	After starting the application	Deletion of temporary files
BEFORE_COPY_FILE_DIALOG	When you create a new version and when the original application files are not checked in before the dialog box for entering a copy path is displayed	Automatic determination of the file name of the new version
AFTER_COPY_FILE_DIALOG	When you create a new version and when the are not checked in after the original application files were copied	Check whether an original application file exists
GENERATE_COPY_FILE_NAME	When you create a new version and when the are not checked in and before the standard process for generating file names is run	Enterprise-specific name conventions for original application files when creating a new version

Integration

You implement the enhancement by using Business Add-In DOCUMENT_FILES01.

Processing of Original Application Files

Used more than once? If yes, where?

General Document Processing

Definition

Interface for an extension where the customer's enterprise-specific requirements for processing documents are implemented.

Use

You can use one or more methods for implementing the interface. You program the enterprise-specific requirements for the method of the Business Add-In.

Structure

The interface of the Business Add-In includes the following method:

Method	Call	Example of a special check
BEFORE_READ_DATA	After the main screen <i>Create, Change, Display</i> and before reading the data	<ul style="list-style-type: none"> • Number check • Version determination • Company authorization check
AFTER_READ_DATA	After the main screen <i>Create, Change, Display</i> and before reading the data	<ul style="list-style-type: none"> • Set the default values • Change data
ASSIGN_NUMBER	When saving	Number determination (instead of routine GET_NUMBER in program MCDOKZNR)
BEFORE_SAVE	Before saving the document but after calling the internal number assignment	Check the data
BEFORE_DELETE	Before setting the deletion indicator	Enterprise-specific logic when deleting
AFTER_SAVE	After saving the document data	Enterprise-specific logic after saving
AFTER_DETERMINE_VALID_VERSION	After determining the valid version	Enterprise-specific determination of the valid versions

Integration

You implement the enhancement by using Business Add-In DOCUMENT_MAIN01.

Used more than once? If yes, where?

General Document Processing (II)

General Document Processing (II)

Definition

Interface for an enhancement you can use to check menu enhancements at the PAI time point.

These checks take place in the following processing situations:

- Create document (CV01N)
- Change document (CV02N)
- Display document (CV03N)

Use

You can use one or more methods for implementing the interface. You program the enterprise-specific requirements for the method of the Business Add-In.

Structure

The interface of the Business Add-In includes the following method:

Method	Call	Example of a special check
D100_BEFORE_PAI	Before the actual PAI of the screen [Ext.] 100	Enterprise-specific checks when selecting a function in DMS
D101_BEFORE_PAI	Before the actual PAI of the screen 101	Enterprise-specific checks when selecting a function in DMS
D100_PAI_CU1	PAI for menu enhancement 1 (+D100_CU1) screen 100	Menu enhancement for the initial screen of document processing
D100_PAI_CU2	PAI for menu enhancement 1 (+D100_CU1) screen 100	Menu enhancement for the initial screen of document processing
D100_PAI_CU3	PAI for menu enhancement 1 (+D100_CU1) screen 100	Menu enhancement for the initial screen of document processing
D101_PAI_CU1	PAI for menu enhancement 1 (+D100_CU1) screen 101	Menu enhancement for the initial screen of document processing
D101_PAI_CU2	PAI for menu enhancement 1 (+D100_CU1) screen 101	Menu enhancement for the initial screen of document processing
D101_PAI_CU3	PAI for menu enhancement 1 (+D100_CU1) screen 101	Menu enhancement for the initial screen of document processing

Integration

You implement the enhancement by using Business Add-In DOCUMENT_MAIN02.

Status checks

Definition

Interface for an extension where the customer's enterprise-specific requirements for status check are implemented.

Use

You can use one or more methods for implementing the interface. You program the enterprise-specific requirements for the method of the Business Add-In.

Structure

The interface of the Business Add-In includes the following method:

Method	Call	Example of a special check
AFTER_CHANGE_STATUS	After every status change according to the status checks of the standard system	Status dependent enterprise-specific checks
BEFORE_LIST_STATUS	Before the list of possible statuses is displayed	Restriction of the list of possible statuses for the selected status check

Integration

You implement the enhancement by using Business Add-In DOCUMENT_STATUS01.

Transport of Original Application Files

Transport of Original Application Files

Definition

Interface for an extension where the customer's enterprise-specific requirements for transport of original application files are implemented.

Use

You can use one or more methods for implementing the interface. You program the enterprise-specific requirements for the method of the Business Add-In.

Structure

The interface of the Business Add-In includes the following method:

Method	Call	Example of a special check
BEFORE_CHECKIN	Before physically transporting the original application file (Check-in)	<ul style="list-style-type: none"> Compress original application file Specify storage area
AFTER_CHECKIN	After physically transporting the original application file (Check-in)	<ul style="list-style-type: none"> Delete original application file on the frontend computer Set status
BEFORE_CHECKOUT	<p>Before physically transporting the original application file (Check-out) create when displaying, changing, printing or copying</p> <p>The call also is possible for original application files that are not checked in.</p>	<ul style="list-style-type: none"> Convert file name Set path for additional files
BEFORE_LIST_STORAGECAT	Before displaying the possible storage categories	Application-specific filter for the list of possible storage categories

Integration

You implement the enhancement by using Business Add-In DOCUMENT_STORAGE01.

Checking the Attributes of the Document Key

Definition

Interface for an enhancement you can use to check enterprise-specific requirements you made in attributes.

The following attributes can be checked:

- Document number
- Document version
- Document part

You can also determine the last and next version number.

Use

You can use one or more methods for implementing the interface. You program the enterprise-specific requirements for the method of the Business Add-In.

Structure

The interface of the Business Add-In includes the following method:

Method	Call	Example of a special check
DOCNUMBER_CHECK	Directly before the standard check in DMS	Enterprise-specific check for document number
DOCVERSION_CHECK	Directly before the standard check in DMS	Enterprise-specific check for document version
DOCPART_CHECK	Directly before the standard check in DMS	Enterprise-specific check for document part
DOCVERSION_GET_NEXT	When creating a new version for determining the template (source) document.	Enterprise-specific report of the last version
DOCVERSION_GET_LAST	When creating a new version for determining the next template (source) document.	Enterprise-specific report of the next version

Integration

You implement the enhancement by using Business Add-In DOCUMENT_NUMBER01.

Filter for DMS processes

Filter for DMS processes

Definition

Interface for an enhancement you can use to check enterprise-specific requirements you made in [processes \[Ext.\]](#). These processes can be integrated into the following functions:

- Find document (transaction CV04N)
- Web scenarios

Use

You can use one or more methods for implementing the interface. You program the enterprise-specific requirements for the method of the Business Add-In.

Structure

The interface of the Business Add-In includes the following method:

Method	Call	Example of a special check
BEFORE_LIST_PROCESS	Before displaying the possible processes	Enterprise-specific checks for processes and making processes available
BEFORE_LIST_STATUS	Currently not implemented	

Integration

You implement the enhancement by using Business Add-In DOCUMENT_PROC01.

Enhancements for Internet Scenarios

Definition

Interface for an enhancement you can use to check enterprise-specific requirements you made in Web scenarios in the area of DMS.

Use

You can use one or more methods for implementing the interface. You program the enterprise-specific requirements for the method of the Business Add-In.

Structure

The interface of the Business Add-In includes the following method:

Method	Call	Example of a special check
FILTER_FILES	Before transferring document data to the IST	Checks and provision of original application files in the Web scenario
GET_URL		Determine URL for checkout in the Web

Integration

You implement the enhancement by using Business Add-In DOCUMENT_WEB01.

Enhancements for Microsoft Office integration

Enhancements for Microsoft Office integration

Definition

Interface for an enhancement you can use to check enterprise-specific requirements you made in [Office Integration \[Ext.\]](#) in the area of DMS.

Use

You can use one or more methods for implementing the interface. You program the enterprise-specific requirements for the method of the Business Add-In.

Structure

The interface of the Business Add-In includes the following method:

Method	Call	Example of a special check
EDIT_LINK_ITEMS	Before transferring data from the SAP System to the Microsoft Office application	Transfer of more data from the SAP System to a Microsoft Office application
AFTER_OPEN	After opening an original application file using Office integration	

Integration

You implement the enhancement by using Business Add-In DOCUMENT_OFFINTEGR01.

Enhancements using User Exits (Document)

Use

In Customizing *Document Management* you can use user exits to create enterprise-specific enhancements and extensions for document processing. You can also use them to extend the standard SAP System with enterprise-specific checks or replace standard ones.

Integration

The enterprise-specific checks can be integrated by means of the ABAP workbench. As opposed to [Customer Exits \[Ext.\]](#) you can use user exits to access program parts and data objects of the standard system.

Some upgrades and support packages will however overwrite the modifications and they must be reentered later.



Verify after an upgrade whether enterprise-specific functions still exist or whether they cause conflicts.

Features

The following overview lists the possibilities for customer-specific changes. The documentation is in the IMG of each activity.

Function	Activity in IMG Document Management	Notes and indications to the SAP Library
Create alternative screen	<i>Control data</i> → Define document types [Ext.] (detail screen)	The alternative screen is only read by the <i>old</i> transactions CV01 to CV03.
Document number assignment	<i>Control data</i> → Define document types [Ext.] (detail screen)	See: Document number [Ext.]
Setting enterprise-specific additional fields	<i>Control data</i> → Define document types [Ext.] (detail screen)	See: Additional Data for a Document [Ext.]
Extensions to the object link	<i>Control data</i> → <i>Define document type</i> → Navigation step Determine object link [Ext.]	See: Adding Other Objects [Ext.] .
Executing a workflow task	<i>Control data</i> → <i>Define document type</i> → Define document status [Ext.]	See: Overview of Additional Functions After Status Changes [Ext.] Processing a Document Info Record (CA-DMS) [Ext.]

Enhancements using User Exits (Document)

Executing enterprise-specific program routines	<i>Control data</i> → <i>Define document type</i> → Define document status [Ext.]	See: Overview of Additional Functions After Status Changes [Ext.]
--	---	--

Enhancements Using Customer Exits (Material Master)

Use

To optimize work flows, you can use [customer exits \[Ext.\]](#) to change some of the functions in the standard material master.



SAP Enhancement MGA00003 makes it possible to edit the display of material numbers as required. For example, if a material is assigned the number 123, you can use this enhancement to define that the material number is displayed with a prefix such as MAT-, even though the number in the database is still 123.

For more information, see the SAP library documentation *Changing the SAP Standard (BC) Customer Exits [Ext.]*.

Features

The following overview shows the enhancements defined for customer exits in the material master.

Enhancements for Function Group XMG0 (General)

Use	Enhancement	Function Module
Extending and adding checks, and (to a restricted extent) changing data	MGA00001	EXIT_SAPLMGMU_001 (enhancements for material master tables)
Influencing how material numbers are assigned	MGA00002	EXIT_SAPLMG02_001 (internal number assignment) EXIT_SAPLMG02_002 (external number assignment)

Enhancements Using Customer Exits (Material Master)

Influencing how material numbers are displayed	MGA00003	EXIT_SAPLOMCV_001 (number conversion from display format to DB format (input: start)) EXIT_SAPLOMCV_002 (number conversion from display format to DB format (input: end)) EXIT_SAPLOMCV_901 (number conversion from DB format to display format (output: start)) EXIT_SAPLOMCV_902 (number conversion from DB format to display format (output: end))
--	----------	--

Enhancements for Function Group XMGV (Distribution of Material Master Data by ALE)

Use	Enhancement	Function Module
ALE distribution	MGV00001	EXIT_SAPLMV01_002 (IDoc creation) EXIT_SAPLMV02_002 (IDoc posting)

Enhancements for Function Group XMG3 (Filter Objects for Material Master Distribution)

Use	Enhancement	Function Module
Reading customer-defined filter objects for a material	MGV00002	EXIT_SAPLMV03_001

Additional Information

In the SAP library documentation [Material Master \(LO-MD-MM\) \[Ext.\]](#):

- [Material Numbers \[Ext.\]](#)
- [Transfer and Distribution of Material Master Data \[Ext.\]](#)

Enhancements in the Area Engineering Change Management

Use

You can change some functions in the area of Engineering Change Management (ECH) with the use of [Customer Exits \[Ext.\]](#) in order to optimize your work processes.



When the person responsible saves a change master record you may want to run self-defined checks to discover any discrepancies in the data and also to keep this data from being saved on the database. You create an enhancement project by using the enhancement PCCD0004 (*Check before saving a change number*). The enhancement contains the function module EXIT_SAPMC29C_005. This exit refers to the include program ZXCCAU05. Enter the program code in the include program.

See also:

[Enhancements to the SAP System in the Area of PDM \[Page 73\]](#) and [The SAP System Enhancement Concept \[Ext.\]](#)

Prerequisites

When you use a function exit you must create an enterprise-specific include program that fits the program logic of the appropriate function module.

Features

The following overview shows the enhancements that are supported for the customer exits in the area of Engineering Change Management (ECH) (development class CC).

Enhancements for the Function Group XCCA

Description	Enhancement	Function Module
Customer field in the change master	PCCD0001	EXIT_SAPMC29C_001 EXIT_SAPMC29C_002
Check of the values of parameter effectivity	PCCD0002	EXIT_SAPMC29C_003
Check when setting a system status	PCCD0003	EXIT_SAPMC29C_004
Check before setting the change number	PCCD0004	EXIT_SAPMC29C_005
Check at initial screen	PCCD0005	EXIT_SAPMC29C_006

The documentation for the individual customer enhancements can be found in each of the enhancements itself in the SAP System. The following shows how to access the documentation for individual customer enhancements:

1. Go to *Tools* → *ABAP Workbench* → *Help* → *Enhancements* → *Definition*.
2. Enter the name of the customer enhancement.
3. Highlight the *Documentation*, option and select *Display*.

Enhancements in the Area Engineering Change Management

Enhancements in BOMs

Use

You can display workflows in the *BOM* area, in a company-specific way, using various enhancement options.



Information about the enhancement options as well as an overview of the planned enhancements for SAP objects in PDM is contained in [Enhancements of the SAP System in PDM \[Page 73\]](#)

Features

The following overview displays the enhancement options for the standard SAP System in *BOMs*.

Enhancement Options	Implementation
Enhancements using Customer Exits [Page 114] See also: Customer Exits [Ext.]	You can display the processing of BOMs in a company-specific way using Customer Exits.
Enhancement using business transaction events [Page 116]	You can write separate programs that are performed when specific events are triggered in the standard SAP System.

Enhancements Using Customer Exits (BOMs)

Enhancements Using Customer Exits (BOMs)

Use

In order to optimize the BOM processing processes in your business, you can change some functions of the SAP System in *BOMs* by using [Customer Exits \[Ext.\]](#).



If an administrator enters a new item in a BOM, you want the system, for example, to automatically check whether the material entered is allowed in this BOM. You create an enhancement project where you use the enhancement PCSD0005 (*component check for material items*). The enhancement contains the function module EXIT_SAPLCSDI_006. This links to the include program ZXCSAU10. Enter your program code into this include.

See also:

[Enhancements of the SAP System in the Area of PDM \[Page 73\]](#) and [Customer Exits \[Ext.\]](#)

Prerequisites

When you use a function exit, you must create a company-specific include program that matches the programming logic of the function module.

Features

The tables below show the enhancements for customer exits used in BOMs (development class CS).

Enhancements for Function Group XCSA

Description	Enhancement	Function Modules
Enhance maintenance of material BOMs	PCSD0001	EXIT_SAPLCSDI_001
Customer fields in item	PCSD0002	EXIT_SAPLCSDI_002 EXIT_SAPLCSDI_003
Customer fields in header	PCSD0003	EXIT_SAPLCSDI_004 EXIT_SAPLCSDI_005
BOM comparison	PCSD0004	EXIT_RCS14001_001 EXIT_RCS14001_002 EXIT_RCS14001_003
Component check for material items	PCSD0005	EXIT_SAPLCSDI_006
Mass Changes	PCSD0006	EXIT_SAPMC29M_001
Check on the changes to BOM header	PCSD0007	EXIT_SAPLCSDI_007
WBS BOM: Customer-specific explosion during create	PCSD0008	EXIT_SAPLCSWB_001

Enhancements Using Customer Exits (BOMs)

Determine standard URL for BOM browser	PCSD0009 [Ext.]	EXIT_SAPLCSSO_001
BOM browser: Determine Explosion Date	PCSD0010 [Ext.]	EXIT_SAPLCSSO_002
Knowledge Based Order BOM: Parallel Updates	PCSD0011 [Ext.]	EXIT_SAPLCSSF_001
Customer material number/material type during material exchange	PCSD0012 [Ext.]	EXIT_SAPLCSME_001
Customer specific processing of an explosion for the BOM browser	PCSD0013 [Ext.]	EXIT_SAPLCSSO_003

You can find the documentation for the individual customer enhancements in the appropriate enhancement in the SAP System. To display the documentation for the individual customer enhancements you:

4. Choose *Tools* → *ABAP Workbench* → *Utilities* → *Enhancements* → *Definition*.
5. Enter the name of the customer enhancement.
6. Select *Documentation*, and click on  *Display*.

Enhancements using Business Transaction Events (BOMs)

Enhancements using Business Transaction Events (BOMs)

Use

In order to optimize *BOM* processes in your enterprise you can use Business Transaction Events to enhance the processing functions of the standard SAP System.

Business Transaction Events are defined parts within a source that can add coding for different software levels, such as branches, partners, or customers, without changing the original program itself.

You use Business Transaction Events, to enhance the standard SAP System with extra components. You can link in-house function modules, or a product from a third party, to the standard SAP System.

See also:

[Using Business Transaction Events \[Ext.\]](#)

Features

Enhancement interfaces are defined in coding of the standard SAP System. If an event is triggered, the system calls up the function modules in which the customer-specific coding is executed.

The tables below show the enhancements for Business Transaction Events used in BOMs (development class CS).

Enhancements for Function Group CSBE

Description	Event SAP-Function Module	Sample Module for Customer Module
Update Bills of Material [Page 117]	CS000010 OPEN_FI_PERFORM_CS000010_E	SAMPLE_INTERFACE_CS000010

Activities

- Create your own function modules (customer modules).
At the same time, copy the sample module as a template.
- Enter your program code into the customer modules.
- In table TBE11 activate the application CS.
This has to be done before the SAP function module calls up the customer modules.
- Assign an event to each customer module in the table TBE34.
If the event is triggered, the system calls up the customer modules, which are assigned to the event in this table.

Update of a BOM (CS000010)

Use

You use this Business Transaction Event to start additional in-house programs during a BOM update.



For example, you can start up external software to check a BOM against your own consistency rules.

Features

The function module OPEN_FI_PERFORM_CS000010_E is called up when the user saves a BOM, but before the system updates the data in the database.

The customer modules are called up using the function module OPEN_FI_PERFORM_CS000010_E.

All data for the corresponding BOM is transferred to the customer module.

Constraints

The interface does not return any data to the standard SAP System.

Enhancements in the Classification System

Enhancements in the Classification System

Use

In order to optimize the business processes in the classification system, you can change some classification functions of the SAP System by using customer exits.



If a user in characteristics maintenance has not maintained default values for finding objects, you can use enhancement CLCTMS01 (*Default values for finding objects*) to define default values in a table or add further values. The enhancement contains the function module EXIT_SAPLCTMS_001. This links to the include program ZXCTMSU01. Enter your program code in this include.

See also:

[Enhancements to the SAP System in the Area of PDM \[Page 73\]](#)

[Customer Exits \[Ext.\]](#)

Prerequisites

When you use a function exit, you must create a company-specific include program that matches the programming logic of the function module.

Features

The following is an overview of the enhancements supported in the classification system (development class CL).

Description	Enhancement	Function Modules	Include
Default values for finding objects	CLCTMS01	EXIT_SAPLCTMS_001	ZXCTMSU01
Check for same classification	CLCTMS02	EXIT_SAPLCTMS_002	ZXCTMSU02
Change or predefine classification of an object	CLFM0001	EXIT_SAPLCLFM_001	ZXCLFU01
Call before updating classification data	CLFM0002	EXIT_SAPLCLFM_002	ZXCLFU02
Selection of objects for mass processing	CLMMD001	EXIT_SAPLCLMMD_001	ZXCLMMDU01
Manipulation of the search result	CLSC0001	EXIT_SAPLCLSC_001	ZXCLSCU01
Object dependencies in object search	CLCTMS03	EXIT_SAPLCTMS_003	ZXCTMSU03

The documentation on individual customer enhancements is in the SAP System with the enhancements themselves. To display the documentation on a customer enhancement:

1. Choose *Tools* → *ABAP Workbench* → *Utilities* → *Enhancements* → *Definition*.

Enhancements in the Classification System

2. Enter the technical name of the customer enhancement.
3. Select *Documentation* and choose  *Display*.

Enhancements in Variant Configuration

Enhancements in Variant Configuration

Use

In order to optimize the business processes in variant configuration, you can change some variant configuration functions of the SAP System by using customer exits.



If a user works with very complex, multilevel configurations, you can control the level of detail shown for the configuration. You can use enhancement CCUX0800 to determine whether all assemblies are exploded or only the configurable assemblies. The enhancement contains function module EXIT_SAPLCUKO_002. This links to include program ZXCUCU05. Enter your program code in this include.

See also:

[Enhancements to the SAP System in the Area of PDM \[Page 73\]](#)

[Customer Exits \[Ext.\]](#)

Prerequisites

When you use a function exit, you must create a company-specific include program that matches the programming logic of the function module.

Features

The following is an overview of the enhancements supported in variant configuration (development class CU).



Constant additions are being made to customer enhancements for variant configuration and this documentation may not include all the possible enhancements. To see the most up-to-date list of enhancements call the F4 help for *Enhancements* and the *Development class CU** for *Infosystem*.

Description	Enhancement	Function Modules	Include
Variant configuration: external APIs	CAVC0000	EXIT_SAPLCAVC_CFG_001 EXIT_SAPLCAVC_INST_001 EXIT_SAPLCAVC_INST_002	ZXCAVCU01 ZXCAVCU02 ZXCAVCU03
Customer-specific batch-input processing	CCUCEI0B	EXIT_SAPLCEI0_020	ZXCEI0U12
Processing of planning tables	CCUP0001	EXIT_SAPLCUD2_800 EXIT_SAPLCUTS_800	ZXCUPU02 ZXCUPU01
Additional checks on configurations	CCUX0000	EXIT_SAPLCUKO_001	ZXCUCU02
Functions for loading configurations	CCUX0001	EXIT_SAPLCUD0_001 EXIT_SAPLCUXC_001	ZXCUCU01 ZXCUCU03

Enhancements in Variant Configuration

Reaction to conflict when finding an object for a class node	CCUX0002	EXIT_SAPLCUD0_002	ZXCUCU04
Parameters for finding an object for a class node	CCUX0003	EXIT_SAPLCEIS_001	ZXCUCU17
Postprocessing of configuration with object dependencies	CCUX0004	EXIT_SAPLCUKO_003	ZXCUCU07
Transfer of item category after material variant matching	CCUX0005	EXIT_SAPLCEB1_001	ZXCUCU10
Fixing an order BOM	CCUX0006	EXIT_SAPLCUKO_007	ZXCUCU13
Definition of the BOM category for instantiation	CCUX0007	EXIT_SAPLCEB1_002	ZXCUCU14
No BOM explosion for externally procured components	CCUX0008	EXIT_SAPLCUKO_008	ZXCUCU15
Synchronization of initialization of variant configuration	CCUX0100	EXIT_SAPLCUD0_003	ZXCUIU01
Configuration: Additional processing for changing variant table contents	CCUX0510	EXIT_SAPLCUD3_001	ZXCUTU02
Effectivity date for order BOM	CCUXDATE	EXIT_SAPLCASL_002	ZXCUC1U03
Control of the level of detail in multilevel configurations	CCUX0800	EXIT_SAPLCUKO_002	ZXCUCU05
Explosion date for result-oriented order BOMs	CCUXDATU	EXIT_SAPLCASL_001	ZXCUC1U01
Maintenance of additional data for instantiation	CCUXIACD	EXIT_SAPLCEB1_100	ZXCUC1U02
Effectivity date for order BOM	CCUXDATE	EXIT_SAPLCASL_002	ZXCUC1U03
Modification for external number assignment for instantiation	CCUXINST	EXIT_SAPLCUKO_004	ZXCUCU09
Find material variants with the same value assignment	CCUCEI0V	EXIT_SAPLCEI0_023	ZXCI0U15
Assigned values file and object characteristics	CCUCEI0A	EXIT_SAPLCEI0_021	ZXCEI0U13
Change F4 help for characteristics in configuration	CCUCEI0H	EXIT_SAPLCEI0_022	ZXCEI0U14
Object types for finding objects for class nodes	CCUXOBTY	EXIT_SAPLCEIS_002	ZXCUCU19

Enhancements in Variant Configuration

Definition of the BOM status for instantiated materials	CCUXSTAT	EXIT_SAPLCEB1_003	ZXCUCU16
Multilevel configuration with material variants	CCUXMVAR	EXIT_SAPLCUKO_009	ZXCUCU20
Component quantity for set development	CCUXSETQ	EXIT_SAPLCUKO_010	ZXCUC2U01
Availability of customer functions in the configuration editor	CEI00000	EXIT_SAPLCEI0_010 through EXIT_SAPLCEI0_019	ZXCEI0U01 ZXCEI0U02 ZXCEI0U03
Configuration: Determine superior material	CUBX0001	EXIT_SAPLCUBX_001 EXIT_SAPLCUBX_002 EXIT_SAPLM60P_003	ZXCUBXU01 ZXCUBXU02 ZX60PU03
Additional logic deleting classification data from the LO-VC view	CUCPDELE	EXIT_SAPLCLDL_002 EXIT_SAPLCUCP_003 EXIT_SAPLCUCP_004 EXIT_SAPLCUCP_005	ZXCUCPU01 ZXCUCPU02 ZXCUCPU03 ZXCUCPU04
Additional logic deleting classification data from the LO-VC view CBASE	CUCPDEL1	EXIT_SAPLCUCP_006 EXIT_SAPLCUCP_007 EXIT_SAPLCUCP_008	ZXCUCPU05 ZXCUCPU06 ZXCUCPU07

The documentation on individual customer enhancements is in the SAP System with the enhancements themselves. To display the documentation on a customer enhancement:

4. Choose *Tools* → *ABAP Workbench* → *Utilities* → *Enhancements* → *Definition*.
5. Enter the technical name of the customer enhancement.
6. Select *Documentation* and choose  *Display*.

See also:

[Specifying Enhancements in the Configuration Editor \[Ext.\]](#)

Archiving

Use

You can use the archiving program to archive data that you no longer require. The data is written to archive files. If this transaction is successful, you can delete the data from the system.



You cannot reload archived BOM data to the R/3 System.

Activities

Choose *Logistics* → *Production* → *Master data* → *Bills of material* → *Extras* → *Archiving*.

For BOMs, archive object **CS_BOM** is defined.

For more information, look in the SAP Library, under *CA* → *Cross-Application Components* → *Cross-Application Data Archiving* → [PP – Production planning and Control \[Ext.\]](#).

See also:

[Archiving PP-BOMs \(PP-BD-BOM\) \[Ext.\]](#)

Features of an Item Category

Features of an Item Category

When you create a new BOM item, you must select an item category for the item. The item category defines the features and functions of an item. The item category determines which specific item data is processed and controls further activities in the system.



If you define an item category for materials with a material type that is kept in stock, stock can be checked automatically.

In Customizing for *Production*, you define the features of the item category by choosing *Bill of Material* → *Item Data* → *Define item categories*. To define an item category, you answer the following questions:

- Is a material number a required entry?
- Is the item to be checked against stock?
- Is the item a text-only item with no further functions?
- Are different-sized sections of the item to be entered?
- Are negative quantities allowed?
- Are sub-items supported?
- Is the item a plant maintenance (PM) structure element?
- Is the item an intra material?
- Is the item a document item or class item?
- Which screens are selected and which fields appear on the item detail screens?

Item Categories in the Standard R/3 System

The standard R/3 System contains the following item categories:

- [Item Categories for Material Items \[Page 127\]](#)
- [Document Items \[Page 133\]](#)
- [Class Items \[Page 134\]](#)
- [Text Items \[Page 136\]](#)

Additional item categories may have been defined in your company. Contact your system manager for information on the special features of these item categories.

Item entry and item category

When you enter an item category, the system makes a number of checks, for example:

- BOM usage

For example, if the BOM usage is for plant maintenance only, plant-specific data is not checked. For this reason, BOM usages for plant maintenance do not support items that are relevant to any one of the following:

 - Design
 - Production
 - Costing
 - Sales and distribution
 - Shipping
 - Spare parts
- Material type of the BOM header and of the item category

When you enter a BOM item, the system checks the material types of both the header material and the material component.

 - Class items can only be entered in bills of material whose header material is of a material type for which configuration is supported.
 - Pipeline materials (material type PIPE) are not kept in stock. They can therefore not be used as stock items in bills of material.
 - Process materials (material type PROC) cannot be used as BOM items.
- Detail screens

For each item category, the system selects several detail screens for data entry and for processing in a fixed sequence.

Item Categories in the Standard R/3 System

Once you have created an item, you can no longer change the item category. If you want to correct the item category for an item, you must delete the item and then recreate it.

Item Categories for Material Items

The standard R/3 System supports several item categories for a material item.



You can classify all material items that have a material master.

You can use the following item categories for material items:

- [Stock Items \[Page 128\]](#)
- [Non-Stock Items \[Page 129\]](#)
- [Variable-Size Items \[Page 130\]](#)
- [PM Structure Elements \[Page 131\]](#)
- [Intra Materials \[Page 132\]](#)

Stock Items

Stock Items

If you want to enter a material that is kept in stock as a component, select this item category.

Before you start

A valid material master record with a material type that supports stock must exist in the plant you select.



Pipeline materials (material type PIPE) are not kept in stock, so you cannot enter them as stock items.

Special functions

The following are examples of functions that are supported for stock items:

- In an **alternative item group**, you can group together all stock items.
- You can use the **discontinuation** functions to transfer dependent requirements that are no longer covered by stock to a follow-up item.

Stock items are handled in the following ways in related application areas:

- For example, in **MRP**, activities are started that ensure that the material is available on a certain date, in sufficient quantity, and at the lowest cost.
 - During materials planning, the system creates dependent requirements for all the material components of a product that are subject to material requirements planning (MRP).
 - When you open a production order, the system generates a reservation.
- **Product costing** functions take the material valuation from the material master record (*Costing view*).

Non-Stock Items

Use this item category if you want to enter a material that is **not** kept in stock before use, and that is only procured for a specific planned order or production order.



The material is only rarely required for a custom-made product and is used directly in the product as a purchased part.

Before you start

You can enter a non-stock item either with or without a material master. If you enter a non-stock item without a material master, you must enter a description. For non-stock items, you have to maintain purchasing data in the bill of material.



You enter the following materials as *non-stock items* because the quantities are not updated in the material master record:

- Materials with a material type that supports *configuration*
- *Pipeline materials*, which can be taken from a pipeline at any time

Special functions

The following functions are supported for non-stock items

- You maintain **purchasing** data for non-stock items in the bill of material.
- In the planning run, the system generates purchase requisitions instead of dependent requirements for components that are procured directly. When you configure your R/3 System for MRP, you can define whether direct procurement is triggered by the planning run or by production order management.
- **Product costing** processes take valuation data from the BOM item. The system determines the release strategy on the basis of the price data you enter. The material group is required to produce a purchase requisition.

Variable-Size Items

Variable-Size Items

If you want different-sized sections of a material (raw material) to be represented by one material number in BOM items, you use this item category.

Before you start

A valid material master record with a material type that supports stock must exist in the plant you select.

Special functions

On the *Detail Screen: Variable-Size Item Data*, the system automatically calculates the quantity of the variable-size item required from the sizes and any formulas entered.



Different-sized sections of a material (for example, sheet metal) can be stored under one material number.

- You can group together all alternative variable-size items into an alternative item group.
- You can use the discontinuation control function to transfer dependent requirements to a follow-up item if they are no longer covered by sufficient stock.

PM Structure Elements

Plant maintenance BOMs contain items that are only used for structuring the equipment (PM assembly). No plant data is required for these materials. For this reason, the system does not check plant data for items with the item category *PM structure element*.

Only use items of this item category in plant maintenance BOMs (for example, equipment BOMs, material BOMs that are relevant to plant maintenance, and functional location BOMs).



These items are not copied to the production order.

Before you start

A valid material master record must exist in the plant you select.

Intra Materials

Intra Materials

This item category is relevant to process industries (master recipes). Materials that only exist temporarily, between 2 subprocesses in the production process, are entered as components with this item category.

Prerequisites

In the standard R/3 System, material type INTR is defined for intra materials. The views you maintain for this material type include:

- Basic data
- Classification
- Quality management

In BOMs, status management for these items is restricted.

Document Item

Document items are supported in all BOM categories (for example, material BOM, equipment BOM), so that you can document the product or component in detail.

In document structures, you can only enter document items and text items.



A document info record must exist in the document management system for the document.

The document info record contains master data for integrating the document into organizational procedures, for example, information on the processing status and storage location of any existing original application files.

Depending on the document type, you can maintain different documents (such as design drawings, photographs, or texts of any word-processing program)



A document in a document item can be copied to a production order. Detailed information can be found in the SAP library under *Production orders (PP-SFC)* → [Document integration in the production order \[Ext.\]](#).

Class Items

Class Items

In a BOM for a configurable material, you can enter a class in which materials or documents are classified as an item. When you configure the material, the class is replaced by one or more materials, according to the characteristic values assigned.

Advantages

For products with many variants, class items make the bill of material easier to maintain.

- The class item is used as a placeholder for an item, and has several objects allocated to it (for example, screws from different suppliers). Each object has a unique identifier in the class. Which object is replaced for the class item depends on the characteristic values that are required for a particular configuration of the material.
- If you enter all the possible objects for an item individually, you must allocate a selection condition to each item, so that only the component you require is selected when you configure the material.

If you use a class item, you no longer need to maintain these selection conditions. When you configure the material, the system selects the component whose characteristic values in the class are identical to those required for this material.



Material requirements planning (MRP) is supported for class items. In Customizing functions for MRP, you can define that a check is made in MRP as to whether an order BOM exists. If an order BOM does exist, requirements for a material selected from a class item are transferred to MRP.

Disadvantage

In a class item, the item quantity is always the same, regardless of which classified material is selected. For this reason, only use class items in cases where you use the same quantity of different materials.

Selecting an object during configuration

A class item can only contain a class for materials or a class for documents. The class type of the class defines which object type (material or document) is classified in the class.

The class in a class item has characteristics. Different characteristic values are assigned to the objects that are classified in the class. During configuration, an object is selected on the basis of these values.

Before you can enter data that is relevant to the object classified in a class item, you must define a *resulting item category*.



If the class type supports material items, you can choose one of the following resulting item categories:

- Stock item,
- Non-stock item (with reference to a material master record)

- Variable-size item,
- PM structure element.

If you configure a BOM, and the system cannot select one material, you see an inconsistency message. You then need to specify more data for the class item.

For more information, see the R/3 Library, under *CA Classification Guide*.

Before you use a class as a class item:

The following requirements must be met before you can use a class as a class item:

- The class must be created with a class type that allows the use of classes in BOMs. In the standard R/3 System, for example, the following class types are supported in BOMs:
 - 200 Material (configurable objects)
 - 201 Document (configurable objects)
 - 300 Variants
- The class type must allow the objects (material, document) classified in the class to be used in BOMs.
- Under the additional class data, you must specify how the class is to be used in BOMs.

You must enter the following data for the component determined by class selection:

- Item category

In the bill of material, you enter the class with the item category *class item*. The item category that the component is to have is the *resulting item category*. You assign this item category to the component when you enter a class item.

- Base unit of measure
- Can one or several objects of the class be selected?

For information on maintaining classes, refer to the R/3 library, under *CA Classification System*.

Text Items

Text Items

This item category is supported for all BOM categories (for example, material BOM, equipment BOM). It allows you to enter a text of any length you require.

The text is processed using the *SAPscript* editor.

This text is saved to the text file using the long-text processing functions.

Entering BOM Items

There are several detail screens for entering and processing item data. The item category determines the selection of screens and the fields on the screen. This means that the item category controls item data maintenance as soon as you create an item.

You enter some item categories **with** reference to a master record, and others **without** reference to a master record.

The following table shows which item categories are maintained with and without a reference to a master record.

Item Entry with and Without Reference to a Master Record

Item category	Object type	Master record
Stock item	Material	Material master record
Non-stock item (with reference to a material master record)	Material	Material master record
Variable-size item	Material	Material master record
PM structure element	Material	Material master record
Intra material	Intra material	Material master record
Document item	Document	Document info record
Class item	Class	Class
Text item	without an object	without
Non-stock item (without reference to a material master record)	without an object	without



When you create an item with reference to a master record, you enter the data that identifies the master record.

You do not maintain as much data for items without reference to a master record.

Tab Page in the Item Detail Screen

Tab Page in the Item Detail Screen

This section tells you which tab pages the various item categories belong to and what data various item categories process.

Some tab pages are relevant to all item categories, and others are only relevant to specific item categories.

The following table shows which tab pages are assigned to the different item categories.

Tab Pages for Item Categories in the Standard SAP System

Tab Page	Valid for Item category	Special points
Basic Data [Page 162]	All item categories	Variable-size item: no <i>quantity entry</i>
		Text item and intra material: <i>quantity entry</i> only
		Document item: only <i>quantity entry</i> and <i>sort string</i>
		Stock item: Indicator: <i>Co-product</i> , alternative item group, and discontinuation data
		Variable-size item: Alternative item group, and discontinuation data
Status/Long Text [Page 193]	All item categories	PM-Structure element: Indicator: <i>PM-Assembly</i>
		Intra material: only <i>item text</i>
Variable-Size Item Data [Page 202]	Variable-size item	
Purchasing Data [Page 204]	Non-stock Item	
Class Data [Page 209]	Class item	
Class Recursiveness [Page 211]	Class item	
Administrative Data [Page 201]	All item categories	
Document Assignment [Page 206]	All item categories with the exception of document items	

Basic data

The *Basic Data* screen contains data that is relevant to all item categories.

The basic data is divided into the following datasets:

- [Identifying BOM Items \[Page 140\]](#)
- [Classification Data \[Page 142\]](#)
- [Quantity Data \[Page 145\]](#)
- [Scrap Data \[Page 150\]](#)
- [General Data \[Page 162\]](#)
- [MRP Data \[Page 177\]](#)

Identifying BOM Items

Identifying BOM Items

Use

Each item has a unique identification in a BOM group (all alternatives of a multiple BOM or all variants of a variant BOM).

Features

The item ID identifies an item. The item ID can only be assigned on the *Item Overview: General* screen or the *General data* item detail screen.

In the standard R/3 System, the item ID can be assigned as follows:

- Internally
If you do not enter an item ID, the system assigns one automatically. Internally assigned item IDs are always numeric.
- Externally
You enter an item ID that has at least one non-numeric character.

An external item ID can only be assigned once in a BOM group. For example, once you assign item ID MAD01 in alternative 01 of a multiple BOM, you can no longer assign item ID MAD01 in alternative 02.

If you want to use the same item ID for different items that belong together (such as different versions of an item), you must define additional settings in Customizing.

See also:

[Entering the Same Item ID for Different Items \[Page 141\]](#)

Entering the Same Item ID for Different Items

Use

You can enter the same external item ID for logically-related items. For example, you might want to define that different versions of an item become effective again under the same item ID.

Prerequisites

You have assigned the item ID of the item externally. In this case, the item ID has at least one alphanumeric character (for example, MA000001).

In Customizing for bills of material, set the following indicators under *Define modification parameters*:

- EC management active
- BOM validity maint.
- Rptd itm effctvty via external item ID

This indicator defines that an item can become effective again under the same external item ID. The system does not check the effectivity conditions, such as the *Valid-from* date.

Procedure

Change the BOM with a change number.

1. Go to the item overview for entering the component – for example, the material item overview for entering a stock item.
2. Check the item ID of the item that you want to replace with a new item as a result of a change (for example, item ID MA000001).
3. Enter the new item.
 - Enter, for example, component and quantity.
 - In the item ID field, enter the item ID that is already defined externally for another item in the BOM group (for example, MA000001).
4. Save your BOM.

Classification Data

Classification Data

Classification data is only relevant to **configurable** BOMs (variant configuration). You can only maintain classification data in the *BOM item* dataset for configurable BOMs.

Classification Data for a BOM Item

In variant configuration, you can use classification data as a selection condition. The system uses this selection condition to select the precise item that is required to produce a specific variant. For example, the system selects RED_COACHWORK for the variant RED_CAR.

You can use classification data as a selection condition for material components and documents. You can only maintain classification data for items of the following object types:

- Material (for example, stock item)
- Document (for example, document item)

You maintain the following classification data in the BOM item:

- Class type
- *Classification as selection condition* indicator

Class Type

The class type must allow classes to be used in configurable objects (for example, bills of material). In the standard R/3 System, this is true for the following class types:

Material classes:	200 – Material (configurable objects) 300 – Variants
Document class:	201 – Document (configurable objects)

The object type of the item determines which class type you can use to classify the item. The object type of the item and the object type of the class type must be the same.



The object type of a stock item is *Material* and the item is linked to database table MARA – *Material master*. In this case, you can only enter a class type that is linked to the material master.

Document info records are linked to database table DRAW – *Documents*. You cannot use a class type for documents to classify a stock item.

Class Allocation

If you want to use the classification of a component as a selection condition, you must classify the component in the classification system. For example, you classify material component RED_COACHWORK in class COACHWORK (assigning values to characteristics COLOR and FINISH). You can only assign one characteristic value to an object in any one class type, so you do not need to enter a class when you maintain the BOM item.

During the configuration process, you must assign values to all the characteristics that were used to classify the material or document. Otherwise, the system cannot find the material or document when you configure the BOM.

Classification as selection condition Indicator

You use this indicator to determine whether the values assigned to the item are read when you configure the BOM.

- Classification as selection condition

The classification data of the item is only read during configuration if this indicator is set. If the values assigned during configuration match the values assigned to an item, the item is automatically copied to the order BOM. For example, you assign value 'Red' to characteristic COLOR, and component RED_COACHWORK is selected automatically.

- Classification for information

If you do not want the classification data to be read during configuration, do not set this indicator. Any class type you enter does not affect the configuration.

See also:

[Entering Classification Data as a Selection Condition \[Page 144\]](#)

Entering Data as a Selection Condition

Use

In configurable BOMs, you can maintain classification data for material items and document items.

Procedure

To maintain classification data:

1. Go to the *Basic data* item screen.
2. In the *BOM item* dataset, enter the class type.
 - The material or document must already be classified in a class of this class type.
3. Decide whether you want classification data to be read when you configure the BOM.
 - If you want to use classification data as a selection condition, set the indicator. When you configure the BOM, you must assign values to all characteristics that are used to classify the material or document.
 - If you want the classification data for information only, do not set the indicator.

Quantity Data

The item category determines which quantity data you enter.

Quantity data for item categories

Quantity data	Item category
Quantity and Unit of Measure [Page 146] Fixed Quantity [Page 148]	all all
Scrap Data [Page 150]	Material items

See also:

[Maintaining Quantity Data \[Page 149\]](#)

Quantity and Unit of Measure

Quantity and Unit of Measure

Quantity

This field shows the exact quantity of the component required to assemble the base quantity in the BOM header.

If you enter a different required quantity, the system multiplies the component quantity by the required quantity you enter. However, if you define the component quantity as a fixed quantity, the component quantity is always the same, regardless of the required quantity.

- The quantity is usually in proportion to the required quantity for the assembly or the order quantity.
- You can define constant quantities as a fixed quantity.

The overview below shows you the special features of the quantities on the *General Item Data* screen.

Item and quantity

Items	Special features of <i>Quantity</i>
Non-stock items, document items, text items	Default value 1
Variable-size items	Quantity entered on <i>Variable-size Item Data</i> screen
Items with sub-items	Quantity calculated automatically from entries on <i>Sub-Item Overview</i>
Co-products and by-products	Negative quantities (for example, 3-)

Unit of measure

This field contains the unit for the component quantity.

The overview below shows you how the unit of measure is determined.

Determining the unit of measure

Item category	Determining the unit of measure
Material item with material master record	Unit of issue or base unit of measure from material master record; Can be replaced by any unit of measure that has the same dimension as the unit of issue or base unit of measure
Non-stock item without a material master, document item, text item	Unit defined in Customizing for <i>Bills of material</i> (step <i>Define modification parameters</i>); standard R/3 System has PC (piece)
Class item	Unit defined in the additional data of the class

Fixed Quantity**Fixed Quantity**

This indicator shows that the quantity of a component does not depend on the quantity of the assembly produced or the order quantity.

- For text items, the system automatically proposes this indicator.
- Fixed quantities are not supported for alternative items and co-products.

Maintaining Quantity Data

When you create an item, you must enter a quantity and a unit of measure. For some item categories, the system checks the master record to determine default values. Before you enter quantity data, enter the data that identifies the master record, and the item category. For more information, see [Entering BOM Items \[Page 137\]](#).

To enter quantity data:

1. Enter the *Quantity*. Enter the *Unit of measure* if you need to.
2. If the component quantity does not depend on the quantity of the assembly produced or the order quantity, set the *Fixed quantity* indicator.

Scrap Data

Scrap Data

You can plan and cost the scrap expected in production in the system.

- MRP automatically adds the scrap quantity to material requirements.
- Product costing uses the scrap to determine excess consumption of materials and services.

You can maintain the following types of scrap:

- [Assembly Scrap \[Page 151\]](#)
- [Component Scrap \[Page 155\]](#)
- [Operation Scrap \[Page 159\]](#)

Assembly Scrap

You maintain assembly scrap in the material master record, not in BOM maintenance.

Assembly scrap takes into account all faults that occur when the individual components of an assembly are assembled (in production).

This entry is ignored in BOMs if the material is not an assembly in the current BOM. The system automatically sets the *Assembly* indicator in a BOM (component overview) for components that have their own BOM.

Calculating Scrap

You can control how scrap is calculated as follows:

- Assembly scrap is calculated for **all** components of the assembly. You maintain assembly scrap in the material master record of the assembly. See [Maintaining Assembly Scrap \[Page 153\]](#).
- Assembly scrap is **not** calculated for **specific** components of the assembly. You maintain component scrap in the BOM. See [Overriding Assembly Scrap \[Page 154\]](#).

See also:

[Assembly Scrap: Example \[Page 152\]](#)

[Maintaining Assembly Scrap \[Page 153\]](#)

[Overriding Assembly Scrap \[Page 154\]](#)

Assembly Scrap: Example

Assembly Scrap: Example

The material master record of header material **RB** contains an entry for assembly scrap. The subordinate component quantities must be adjusted to include the scrap.

Header material RB – base quantity:	1 piece
Component HBAR – component quantity:	1 piece
Required quantity (RB):	1 000 pieces
Assembly scrap (RB):	10 %
→ Scrap quantity:	100 pieces

The resulting component quantities for assembly **RB** are calculated for 1,100 pieces of assembly **RB** (racing bike).

Maintaining Assembly Scrap

You maintain assembly scrap in the material master record only.

To maintain assembly scrap:

1. Choose *Material* → *Change* → *Immediately* or *Schedule*.
2. Enter the organizational level (for example, plant 0001) and select view *MRP*.
3. On the *MRP* screen, enter a percentage for assembly scrap.
4. Save your material.

Exclude Assembly Scrap

Exclude Assembly Scrap

Use

In certain situations, you do not want the system to calculate assembly scrap for a component in the assembly. You can exclude assembly scrap for this component in the BOM.



In the BOM, you can replace the assembly scrap in the material with operation scrap.

Procedure

To exclude assembly scrap for a component:

1. Choose *Logistics* → *Production* → *Master data* → *Bills of material* → *Bill of material* → *Material BOM* → *Change*.

2. Enter your data on the initial screen and confirm.

The item overview appears.

3. Mark the item for which you want to exclude assembly scrap.

4. Click .

The *Change Material BOM* screen appears: *Item: All Data*.

Enter the indicator *Net* (Operation net indicator) under quantity data in the tab page *Basic Data*.

5. Save your BOM.

Component Scrap

The component scrap is defined to take into account all faults that occur before the component is put into an assembly (material provision scrap).

This is possible in the following situations, for example:

- A percentage of the parts to be assembled is already defective on delivery.
- Losses occur during storage.

Component scrap only affects **one** component of an assembly. When you explode the BOM, the system increases the quantity of that component by the **Scrap quantity** calculated.

In product costing, this value is used to determine excess consumption of materials or activity.

There are two ways to maintain component scrap:

- In the BOM on the *Item detail screen: general data* under *Quantity data*.
This component scrap is only relevant to the **individual** BOM.
- In the material master record on the *MRP 2* screen under *Requirements explosion*
If the same component scrap applies to a material in a number of BOMs, we advise you to maintain the component scrap in the material master record.



If the component scrap for a material is the same in all BOMs, maintain the scrap in the material master record.

Calculating scrap

Component scrap only applies to one component.

The component scrap maintained for a material component in a **BOM** overrides the component scrap maintained in the material master record. If you maintain component scrap in the BOM, the system always uses the component scrap in the BOM to calculate component quantities. If you do not maintain component scrap in the BOM, the system uses the component scrap stored in the **material master record** to calculate component quantities.

See also:

[Component Scrap: Example \[Page 156\]](#)

[Maintaining Component Scrap in the BOM \[Page 157\]](#)

[Maintaining Component Scrap in the Material \[Page 158\]](#)

Component Scrap: Example

Component Scrap: Example

In your BOM, component scrap is maintained for a material component. The component quantity must be adjusted to include the scrap.

Material component HBAR – component quantity:	1,000 pieces
Component scrap:	5 %
→ Scrap quantity:	50 pieces

1,050 pieces of component **HBAR** (handlebar assembly) are required.

Component Scrap and Assembly Scrap

Assembly scrap is maintained in the material master record of assembly **BIKE**. In your BOM, component scrap is maintained for a material component. The component quantity must be adjusted to include the scrap.

Quantity of BIKE to be produced (required quantity):	1,000 pieces
Assembly scrap (HBAR):	10 % (100 pieces)
→ Adjusted required quantity:	1,000 pieces
Plus component scrap for HBAR :	5 % (55 pieces)
→ Total scrap quantity for HBAR:	155 pieces

If an adjusted required quantity of 1,100 pieces of racing bicycles is to be produced, 1,155 pieces of component **HBAR** (handlebar assembly) are required.

Maintaining Component Scrap in the BOM

Use

If the scrap is only relevant to **one** specific BOM, maintain component scrap in the BOM item.

Procedure

To maintain component scrap in the BOM:

1. Select the tab page *Material* in the item overview.
2. Mark the item for which you want to maintain component scrap.
3. Click .

The *Change Material BOM* screen appears: *Item: All Data*.

4. Enter the percentage rate for the component scrap in the field *CompScrap (%)*.
6. Save your BOM.

Maintaining Component Scrap in the Material

Maintaining Component Scrap in the Material

If scrap is relevant to the material in **all** BOMs, maintain component scrap in the material master record.

To maintain component scrap in the material master record:

1. Choose *Material* → *Change* → *Immediately* or *Schedule*.
2. Enter the organizational level (for example, plant 0001) and select view *MRP 1*.
3. On the *MRP 1* screen, enter a percentage for component scrap.
4. Save your material.

Operation Scrap

Before an operation in which high-value components are built into an assembly, a quality inspection of the assembly may take place. Faulty materials that are covered by assembly scrap are taken out of the process before the next operation. This is why you enter an operation scrap instead of a general assembly scrap for high-value components.

The operation scrap is the quantity of **one** component to be processed in an operation. This value enables you to plan material requirements and determine excess consumption more precisely.

Calculating scrap

You maintain operation scrap for an individual component.

If this component is contained in an assembly for which assembly scrap is maintained, **only** the operation scrap is taken into account.

See also:

[Operation Scrap: Example \[Page 160\]](#)

[Maintaining Operation Scrap \[Page 161\]](#)

Operation Scrap: Example

Operation Scrap: Example

Operation scrap is maintained for 2 material components in the BOM. One component is also subject to assembly scrap. The component quantities must be adjusted to include the scrap.

Quantity of material RB to be produced (required quantity)	1,000 pieces
Assembly scrap:	10 % (pieces)
Component 1: Operation scrap: Net indicator: → Scrap quantity	no entry not <i>selected</i> → assembly scrap used in calculation 100 pieces
Component 2: Operation scrap: Net indicator: → Scrap quantity	1 % selected, therefore assembly scrap not used in calculation 10 pieces

Before component 2 is built into the assembly, the faulty assemblies are taken out of the process, and only the operation scrap is calculated.

The quantity for component 1 is for 1,100 racing bicycles to be produced. The quantity for component 2 is for 1,010 racing bicycles to be produced.

Maintaining Operation Scrap

Use

The operation scrap is maintained in the BOM under the tab page *Basic Data* in the item detail screen.

Procedure

To maintain operation scrap in the BOM:

1. Select the tab page *Material* in the item overview.
2. Mark the item for which you want to maintain operation scrap.
3. Click .
4. Enter the percentage rate for the operation scrap in the tab page *Basic Data*, under quantity data, in the field *Operation Scrap (%)*.

If you do not want assembly scrap (if applicable) to be calculated as well set the net indicator (Net-Indicator).

7. Save your BOM.

General Data

General Data

In this dataset, you maintain data that is relevant to different areas in a company, and can only be maintained in certain processing situations.

The following data is maintained under general data:

- [Co-product \[Page 163\]](#)
- [Recursiveness Check \[Page 164\]](#)
- [Alternative Items in an Alternative Item Group \[Page 167\]](#)
- [Discontinuation Data \[Page 171\]](#)
- *CAD indicator*

The system sets this indicator if the item is generated in a CAD system and transferred to the SAP System via an interface.

This indicator is relevant to all item categories except document items.
- *ALE Indicator*

The system sets this indicator when a BOM was distributed via ALE in the SAP-System.
- *Reference Point*

You maintain a reference point when you want to transfer a BOM into the Project System.

Co-Products

Select this field for a material that is produced during the same process as other basic materials. These items are treated as material credit memos for costing purposes and reduce manufacturing costs.

You can only select an item as a co-product if the following requirements are met:

- Material master record
The *Indicator: material can be co-product* must be set in the MRP data.
- Bill of material
The material item
 - Must have item category *Stock item*.
 - Must not be allocated to an alternative item group.

Special features for maintaining items

The following special points apply to co-products:

- You must enter the component quantity as always a negative value (for example, 3-).
- You cannot set the fixed quantity indicator.
- You cannot maintain discontinuation data.

Recursiveness Check

Recursiveness Check

A BOM is recursive if the product contains a component with the same object number as the superior assembly. This is often due to input errors, but in individual cases it may be intentional.



A component has the same material number as a higher-level product. In paint production, a residual quantity of the paint to be produced is used as a component.

The figure below shows the repeated explosion of an object within an explosion path (recursiveness).

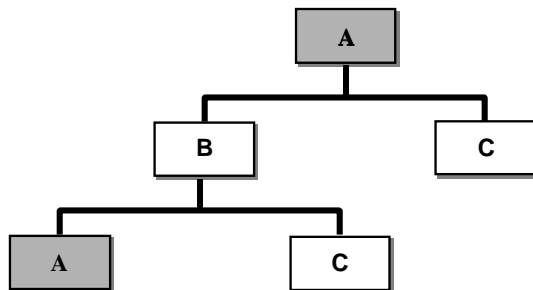

Recursiveness check within a BOM group

The recursiveness check includes all BOMs in a BOM group. For example, the system finds recursiveness in a variant BOM, even if an individual variant is not recursive.



A variant BOM has 2 variants:

- The first variant for material **A** has the following material components:
 - Item 0010 with material B
 - Item 0020 with material C
- The second variant for material **B** has the following material components:
 - Item 0010 with material A
 - Item 0020 with material C

Neither variant is recursive. However, the system finds the following material components to be recursive:

- In variant for material **A**: item 0010 with material **B**
- In variant for material **B**: item 0010 with material **A**

BOM explosion for recursive BOMs

BOM explosions stop at the component that causes recursiveness.

See also:

[When is a BOM Explosion Terminated? \[Page 397\]](#)

[Allowing Recursiveness \[Page 166\]](#)

Allowing Recursiveness

Allowing Recursiveness

If you create a recursive BOM, you must decide whether you want to allow recursiveness or delete the component that caused the recursiveness.

Recursiveness online

You enter a material item that causes recursiveness. If you confirm your entry, the system recognizes the recursiveness.

Processing comprises the following phases:

1. The system
 - a) Sets the *Bill of material is recursive* indicator
 - b) Displays the error message *Bill of material is recursive*
 - c) Goes to the General data screen
2. You process the item in the BOM.
 - a) If you want the BOM to be recursive, you set the *Recursiveness allowed* indicator in the *General data* of the item.
 - b) If you do not want the BOM to be recursive, delete the item.

Recursiveness on update

In exceptional situations, recursiveness is only recognized by the update program. The user is no longer working on the BOM and cannot receive an online message about recursiveness.



Two users create a material BOM at the same time. Each user enters the BOM header material entered by the other user as a component. One user saves the BOM. When the second user tries to save the BOM, the system recognizes recursiveness and sets the recursive indicator. The second user sees an online message about the recursiveness.

Alternative Items in an Alternative Item Group

An alternative item group is used to group together alternative items in a BOM. Any of the materials in the alternative item group could be included in the assembly. These items are known as alternative items in the BOM.

You can use alternative items in the following situations:

- **Alternative items with a usage probability**

The alternative items are included with a certain usage probability.

- Material requirements planning (MRP) uses the usage probability to determine dependent requirements for the materials.
- In the production order, dependent requirements are converted to a reservation.

The withdrawal posting for the reservation in the production order uses either the usage probability or the 100% availability check according to ATP logic.

- **Alternative items for information**

You can enter an alternative item for information only. For example, the item is only relevant to missing parts. The usage probability for the item is 0&.

See also:

[Data for Alternative Items \[Page 168\]](#)

[Strategy: Example \[Page 169\]](#)

[Maintaining Alternative Items \[Page 170\]](#)

Data for Alternative Items

Use

When you enter an alternative item group for the item, you can enter the *Priority*, *Strategy*, and *Usage Probability* in a dialog box.

Features

Usage Probability

Material requirements planning (MRP) plans the alternative items according to usage probability.

If you use the usage probability to determine the withdrawal posting (strategy 1), the quantities are proposed according to the usage probability. You can change the proposed quantities.

- An alternative item is only planned if the usage probability is at least 1%.
- If the usage probability is 0%, a dependent requirement with quantity 0 is generated for the material.
 - The component with the quantity 0 is displayed in the planned order. If required you can increase the quantity there.
- It is possible to plan too much for alternative items, because you can enter usage probabilities that add up to more than 100%.

Priority

The priority of an item within an alternative item group determines the sequence in which material components are reserved in the production order.

Strategy

The strategy is only relevant to the withdrawal posting in the production order. The strategy is ignored in MRP.

You use the strategy to determine how the items within an alternative item group are selected for the withdrawal posting. Use the same strategy for all alternative items in an alternative item group.

The following strategies for withdrawal postings are supported:

- Withdrawal according to usage probability (manual changes possible)
- Withdrawal if availability is 100%

Strategy: Example

If you use this strategy, the availability checks uses ATP logic according to the priorities you define.

100% Availability

Gross requirements: 100 pieces

Calculating issue quantity for 100% availability

Material	Percentage usage probability	Priority	Planned requirement qty	ATP qty	Issue quantity
A	20	1	20	30	0
B	30	2	30	150	100
C	50	3	50	180	0

The required quantity of the first material in order of priority that covers 100% of requirements is reserved (material B).

The system sets the usage probability of the reserved material to 100%. The quantity and usage probability of the other alternative items (materials A and C) are set to 0.

Missing Parts Situation

When none of the alternative items cover the requirement 100% on the requirements date, the availability check confirms a 0 quantity for all the items. This means that there is no reservation.

Maintaining Alternative Items

Prerequisites



Before you maintain alternative items, decide the following points for MRP and withdrawal postings:

- Do you want to assign the same item number to all alternative items in an alternative item group?
- Which character string do you want to use to group alternative items together in an alternative item group?
- What is the usage probability for the individual alternative items in the assembly?
- What are the priorities of items in an alternative item group?
- Which strategy do you want to use for withdrawal postings?

Procedure



To maintain alternative item data:

1. Select the tab page *Material* in the item overview.

You will find it easier to use the same item number for all the items in an alternative group. Change the item numbers if necessary.
2. Select the items that you want to group together in an alternative item group.
3. Click .
- The item detail screen of the first item selected appears.
4. On the *Basic data* tab page, enter the alternative item group in the group frame *General Data* and click .
- You see the *Alternative item data* dialog box, in which you enter the following data:
 - *Priority*
 - *Strategy*

Enter the same strategy for all alternative items in an alternative item group.
 - *Usage Probability*

If you enter a usage probability, then the alternative item serves as information. In this case, the system displays an appropriate warning message.
5. Confirm your entries.

The system goes back to the item detail screen. The  button is displayed alongside the *AltItemGrp* field. By clicking on this button you can later change the data.
6. By clicking on , the next alternative item appears. Repeat steps 4 and 5 for each alternative item.

Discontinuation

In material requirements planning (MRP), the discontinuation data in the material master record transfers dependent requirements for a material component that is no longer in stock (in sufficient quantities) to a follow-up material. You can also specify a follow-up material for an item in a BOM. The data for this is maintained as *Discontinuation data*.



The follow-up item specified in the BOM overrides any follow-up material maintained in the material master record.

Multiple levels of discontinuation data are not supported. Once a material master record (MRP data) has discontinuation indicator **1** (simple/parallel discontinuation) and a follow-up material, you can no longer enter the material as a follow-up material in a BOM.

Prerequisites

Before you can use discontinuation, the following must be true:

- Both materials are planned using MRP
- The base unit of measure of the follow-up material is the same as the base unit of measure of the discontinued material
- In the BOM, discontinuation data is maintained for the discontinued item and follow-up data is maintained for the follow-up item
- The system checks the following item data:

- *Item category*

You can define discontinuation data for the following item categories:

- Stock item
- Variable-size item

You **cannot** define discontinuation data for the following item categories:

- Document item
- Text item
- Class item
- Intra material

- *Alternative item group*

You can only define discontinuation data for a stock item or variable-size item that is not assigned to an alternative item group.

Once you have maintained discontinuation data for an item, you can no longer assign the item to an alternative item group.

- *Co-products*

Discontinuation is not supported for co-products.

See also:

Discontinuation

[Discontinuation Data \[Page 173\]](#)

[Discontinuation: Examples \[Page 175\]](#)

[Maintaining Discontinuation Data \[Page 176\]](#)

Discontinuation Data

Use

You display and enter the data for discontinuation in a dialog box.

- *Discontinuation indicator*
- *Discontinuation groups*
- *Follow-up groups*

Features

Discontinuation Indicator for Discontinued Material

If this indicator is set, the material is defined as 'to be discontinued'. The material is then discontinued in MRP. MRP transfers dependent requirements that are no longer covered by stock of this material to the follow-up material.

You maintain this indicator in the MRP data of the material master record. In the BOM maintenance, the system displays the value in the *Material Master Record*. If the bill of material is assigned to several plants, you see the discontinuation indicator for the initial plant.

Discontinuation groups

This freely-definable character string groups together related discontinued items in a BOM.

- You can only enter a discontinuation group for an item if the discontinuation indicator is selected in the *MRP* data of the material master record. This discontinued item is replaced by a follow-up item.

A follow-up group is maintained for the follow-up item. The follow-up group for the follow-up item should have the same value as the discontinued item it is replacing (see [Examples of Discontinuation \[Page 175\]](#)).
- You can implement a discontinuation group via a [Parallel Discontinuation \[Ext.\]](#). When an item is discontinued (the main item to be discontinued), the other items in the discontinuation group (subordinate items to be discontinued) are automatically replaced at the same time.

If you want to implement parallel discontinuation, you must define the following settings:

- **Material Master Record** (View *MRP 4*):

You use the *Discontinuation indicator* to control discontinuation. If the material is the main material to be discontinued, enter the value **1**. If the material is a subordinate material to be discontinued, enter the value **3**.

- **Bill of material:**

You enter the same discontinuation group for the main item to be discontinued and the subordinate item to be discontinued (see [Example of Discontinuation \[Page 175\]](#)).

Follow-Up Groups

This freely-definable character string:

Discontinuation Data

- Groups together related follow-up items in a BOM
- Determines which discontinued items this follow-up item replaces

The follow-up item replaces the discontinued item that has this same value in the *Discontinuation group* (see [Example of Discontinuation \[Page 175\]](#)).

Entering a Follow-Up Group:

- You can only enter a follow-up group if the item is kept in stock (for example, a stock item).
- You can only maintain an item as a follow-up item when you first enter the item. Once you have saved the item, you can no longer change the value in this field.

Changing a Follow-Up Group:

If you change the item data of a follow-up item (for example, the item quantity), the system creates a new item record.

Examples of Discontinuation

Example 1: Discontinued Item (Simple Discontinuation)

In **simple** discontinuation, the discontinued item 0010 (material M-1) is replaced with the follow-up item 0010 (material M-2) and 0010 (material M-3).

In the material master of material M-1, the discontinuation indicator is set to 1.

This example is illustrated in the following table.

Item	Material	Discont. group	Follow-up group
0010	M-1	A1	
0010	M-2		A1
0010	M-3		A1

Example 2: Discontinued Item (Parallel Discontinuation)

In **parallel** discontinuation, the discontinued items 0010 (material M-1) and 0010 (material M-2) are replaced by follow-up item 0010 (material M-3).

Material M-1 is the main material to be discontinued (discontinuation indicator 1) and material M-2 is the subordinate material to be discontinued (discontinuation indicator 3). Material M-3 is the follow-up item.

This example is illustrated in the following table.

Item	Material	Discont. group	Follow-up group
0010	M-1	A1	
0010	M-2	A1	
0010	M-3		A1

Example 3: Follow-Up Item

In **simple** discontinuation, item 0010 (material M-2) replaces 0010 (material M-1).

This example is illustrated in the following table.

Item	Material	Discont. group	Follow-up group
0010	M-1	E1	
0010	M-2		E1

Maintaining Discontinuation Data

Maintaining Discontinuation Data

You enter data for discontinuation on the *General Item Data* screen. To call the function for entering discontinuation data:

1. If you are on an item overview, select the material component first.
If you are on an item detail screen, go directly to step 2.
2. Choose *Extras* → *Discontinuation data*.
You see the *Discontinuation data* dialog box. The data that identifies the item is in the first line:
 - *Item number*
 - *Material*
 - *Item category*
3. The next step depends on whether your item is a discontinued item or a follow-up item.

Entering data for a follow-up item

You can only define an item as a follow-up item in the BOM item.

- Enter the *Follow-up group* for the follow-up item.
- Enter the same character string as the *Discontinuation group* of the item you want to replace.

Entering data for a discontinued item

To allow an item to be discontinued, you must enter the discontinuation indicator in its material master record. In the BOM item, you see this indicator in the *Discontinuation data*. You can only discontinue items that have this indicator.

- Enter the *Discontinuation group* of the item you want to discontinue.
 - Enter the same character string as the *Follow-up group* for the item that is to replace the discontinued item.
4. Go back and save your BOM.

MRP Data

The planned order creates an independent requirement for the assembly with an order start date and an order finish date.

The order start date of the superior assembly is automatically the requirements date for the resulting dependent requirements (material requirements for subordinate components).

The system uses a number of factors (for example, in-house production time, processing time, and interoperation time) to calculate the start date of the planned order for procuring components.

You can maintain the following material requirements planning (MRP) data for a BOM item:

- [Entering a Lead-Time Offset \[Page 178\]](#)
- [Distribution Key \[Page 182\]](#)
- [Special Procurement Key \[Page 183\]](#)
- [Explosion Types \[Page 185\]](#)

See also:

[Maintaining MRP Data \[Page 192\]](#)

Entering a Lead-Time Offset

Entering a Lead-Time Offset

Application

This field shows the number of working days before or after the production start date of the superior material when the component must be available.

Integration

The lead-time offset is ignored in lead-time scheduling for task lists.

Functions

You can enter a negative value or a positive value.

- **Positive value**

The component is not required immediately. It can be available this number of days after the start of production.

- **Negative value**

The component is required this number of days before the start of production.



The following graphic shows how the order finish date of a component relates to the order start date of the superior assembly.

Different lead-time offsets are entered for three different components.

Determining the Order Finish Date for a Component: Example

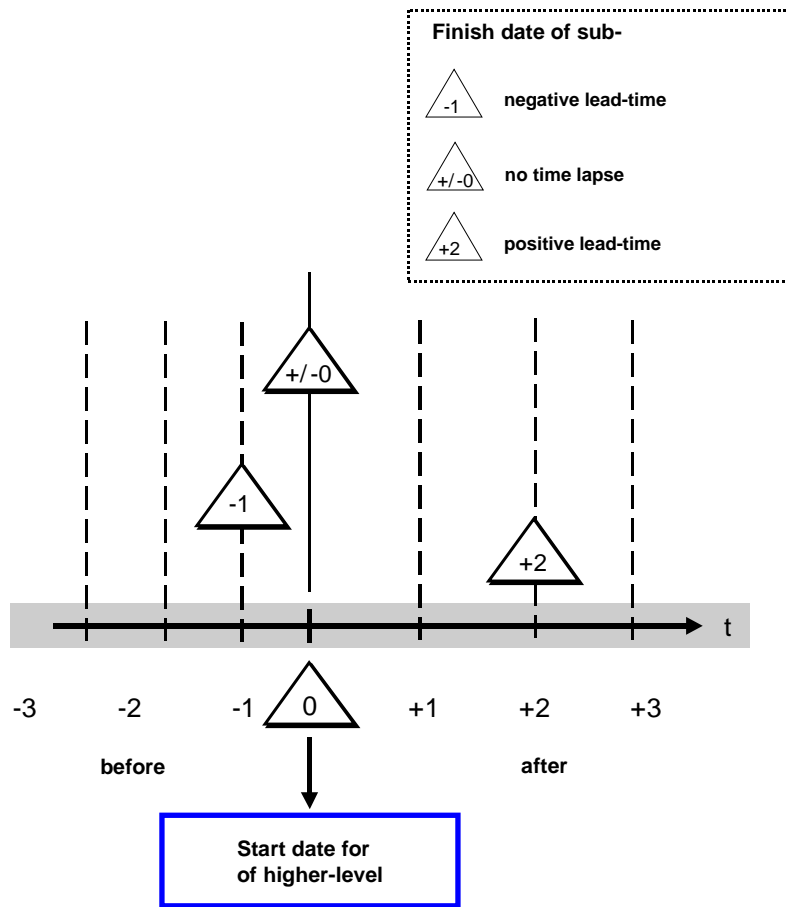

Determining the Order Finish Date for a Component: Example

The start date of the superior assembly is **05/10/98**

Lead-time offset	Relation in time to order start date of superior assembly	
1-	before	05/09/1998
0	Start date for superior assembly = Finish date for subordinate assembly	05/10/1998
2+	after	05/12/1998

Determining the Order Finish Date for a Component: Example

This table does not show the start date for the components, as there is insufficient data (on, for example, in-house production time, processing time, or interoperation time).

Entering a Lead-Time Offset for an Operation

Use

You can use this value to enter the lead-time offset for a component in relation to the start date of the operation to which the component is assigned.

Integration

The following application areas read the lead-time offset for an operation:

- Maintenance orders
- Networks
- Production orders

Features

You can enter a positive or negative value for the lead-time offset.

See also:

[Entering a Lead-Time Offset \[Page 178\]](#)

Distribution Key

Distribution Key

In this field, you can enter the distribution key for dividing up dependent requirements or reservations for this component over time.



In Customizing for *Production*, you define distribution functions by choosing *Repetitive manufacturing* → *Planning* → *Distribution* → *Define function*.

If you enter a distribution function for a component, portions of the dependent requirement are distributed over the runtime of the planned or production order in accordance with the distribution function.

This means that dependent requirements are not available in full on the order start date. Instead, they are brought into the production process continuously between the order start date and the order finish date.

The last portion of the dependent requirement must be available at the latest on the finish date of the assembly.



If, for example, the last portion of a dependent requirement must be available 2 days before the finish date, you can enter a negative lead-time offset (2-).

Special Procurement Key

This indicator determines the special procurement type of a material that is either procured externally or produced in-house.

The system determines the special procurement key from the *Procurement type* and *Special procurement* fields in the material master record (*Detail Screen: MRP 1*) and displays the value if the BOM is only assigned to one plant.

The system only displays the values that are relevant to the explosion type for a BOM item.

- *Phantom assembly*
- *Direct production (collective order)*

Phantom Assembly

A phantom assembly is only required for engineering/design. It does not occur physically in the course of production. In the planning run, the component materials of the assembly transfer requirements. The header material of the assembly is not planned.

The following graphic shows how a BOM that contains a phantom assembly (component B) is exploded for engineering/design and for production in the standard R/3 System. The engineering/design explosion includes the phantom assembly, whereas production only includes the components of the phantom assembly (components B1 and B2).

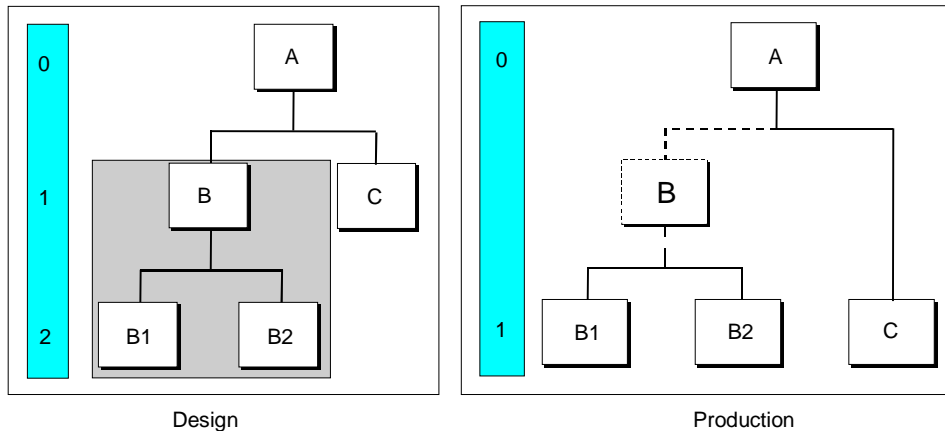

In the standard R/3 System, the special procurement key *phantom assembly* has the value **50**.

Direct production (collective order)

Material components of this special procurement type are produced in an order network using a special production order.

In the standard R/3 System, the special procurement key *direct production (collective order)* has the value **52**.

If the BOM item is an assembly with a special procurement key, subsequent applications explode the item according to the explosion type (for example, for the planning run).

In Customizing for *Production*, you define the explosion type by choosing *Bill of Material* → *Item data* → *Define explosion types*.

Special Procurement Key

See also:

[Explosion type \[Page 185\]](#)

Explosion Types

The explosion type determines the procedure that is used to explode the BOM in order to determine dependent requirements.

You can also use this key to control the explosion of the BOM for the planning run.

This allows you, for example, to define the explosion of assemblies with a special procurement key according to various criteria.

Indicators that Control BOM Explosion

In Customizing for *Production*, you define whether the following system activities take place by choosing *Bill of Material* → *Item Data* → *Define explosion types*:

- [Switching Off the Phantom Assembly \[Page 186\]](#)
- [Switching Off Planning \[Page 188\]](#)
- [Switching Off Direct Production \(Collective Order\) \[Page 189\]](#)
- [Long-Term Planning \[Page 190\]](#)
- [Individual/Collective Requirements for Dependent Requirements \[Page 191\]](#)

Switching Off the Phantom Assembly

Switching Off the Phantom Assembly

Standard Explosion for Phantom Assembly

If the material master record of a BOM header material contains the special procurement key *Phantom assembly* (value 50 in the standard R/3 System), dependent requirements are generated for components of the phantom assembly, and planned orders or purchase requisitions are created only for these components.



In the material master of material B, *Phantom assembly* is set in the *Special procurement* field.

Material B is a material component in a BOM and has item number 0010. It also has a BOM of its own, containing components B1 and B2.

In the standard system, dependent requirements are generated for components B1 and B2 when the BOM is exploded in MRP.

The following graphic shows how a BOM that contains a phantom assembly is exploded for production. The phantom assembly (component B) is ignored. Only the components of the phantom assembly (components B1 and B2) are read.

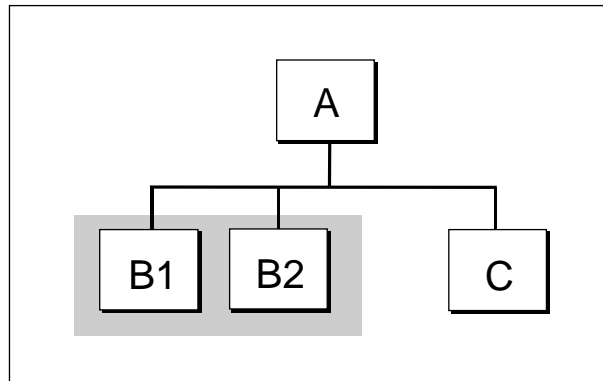

Using the Explosion Type to Explode a Phantom Assembly

You can define an explosion type that generates dependent requirements for materials that have the *Phantom assembly* special procurement key.

To do this:

- Define an explosion type that has the *Phantom assembly off* indicator
- Assign this explosion type to the BOM item that is defined as a phantom assembly



In Customizing, explosion type A is defined so that the *Phantom assembly off* indicator is set.

Material B is a material component in a BOM. It also has a BOM of its own, with components B1 and B2.

Switching Off the Phantom Assembly

- In the material master of material B, *Phantom assembly* is set in the *Special procurement* field.
- In BOM item 0010 (material component B), the value *A* is set in the *Explosion type* field.

The following graphic shows how a BOM that contains a phantom assembly (component B) is exploded. The explosion type is set to *Phantom assembly off*. This means that material B is included in the planning run.

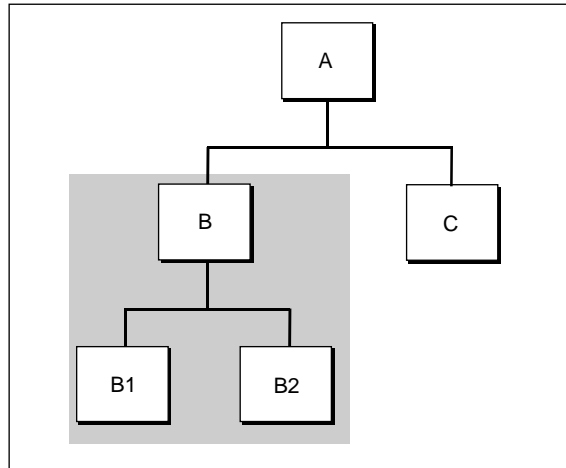

Switching Off Planning

Switching Off Planning

The *Planning off* indicator is relevant to multi-level production with assemblies that are not produced in advance.

If the production time is long in relation to the usual delivery time, the replenishment lead time must be kept short. For this reason, the components and assemblies of the final product are produced in advance, but final assembly does not take place until a sales order is received (for example, in the case of cost-intensive materials or operations).

The replenishment lead time for some components, such as purchased parts, can be very short. You do not need to plan these components.

Demand management supports the following sales-order-based planning and production strategies, which are oriented toward make-to-order production in demand management.

- *Planning without final assembly*
- *Planning with planning material*

You can define an explosion type that generates dependent requirements for materials with the *Planning off* special procurement key.

For these components with a short replenishment lead time, you define an explosion type that does not generate dependent requirements and therefore is not planned.



In Customizing, explosion type **B** is defined so that the *Planning off* indicator is set.

- You enter material component M-2 as item 0020 of the BOM.
- In BOM item 0020 (material component M-2), the value **B** is set in the *Explosion type* field.

In the planning run, no dependent requirements are generated for component M-2.

Switching Off Direct Production (Collective Order)**Switching Off Direct Production (Collective Order)**

Components with this indicator are produced directly for the superior assembly in the R/3 System. The planned order produced for the component is linked to the superior assembly. If components are produced directly for the superior assembly, dependent requirements are selected accordingly. The system generates a special planning segment under the heading *Direct production*.

You can define the explosion type so that *Collective orders* are switched off for the component.

In the MRP data of the material master record for the component, enter dependent requirements indicator **2** (collective requirements only).

Long-Term Planning

Long-Term Planning

Long-term planning allows you to simulate materials planning, in parallel to operational materials planning, across all low-level codes. This means that you can use the current bills of material to determine the effects of a planned production program on the material requirements and the capacity load.

In the standard R/3 System, long-term planning affects all low-level codes. However, if the BOM is very large, long-term planning can affect system performance. For this reason, you can switch off long-term planning for a low-level code if it is no longer required.

Individual/Collective Requirements for Dependent Requirements

This indicator controls whether individual or collective customer requirements planning is allowed for dependent requirements.

If you define *individual requirements* for explosion, dependent requirements for a component are shown individually on the superior low-level code.

If you define *collective requirements* for explosion, required quantities for the material are summarized independently of the sales order.

Maintaining MRP Data

Maintaining MRP Data

You can see the BOM in the item overview.

1. Mark the item for which you want to maintain MRP data.
2. Click .

The *Change Material BOM* screen appears: *Item: All Data*.

3. Enter values in the tab page *Basic Data* for one or more of the following fields:
 - *Lead-time offset*
 - *Operation lead-time offset*
 - *Distribution key*
 - *Explosion types*
 - *Special procurement*
4. Save your BOM.

Status/Long Text

On the *Detail Screen: Status/Long Text*, you process fields for item status, item text, and plant maintenance data.

[Item Status \[Page 194\]](#)

[Additional Data for the Item \[Page 196\]](#)

[Item Text \[Page 199\]](#)

[PM Assemblies \[Page 200\]](#)

Item Status

Item Status

In Customizing for *Production*, you define BOM usages for your company that control the possible item statuses by choosing *Bill of Material* → *General Data* → *BOM Usage* → *Define BOM usages*, which.

See also:

[BOM Usage \[Page 41\]](#)

You can define indicators that describe the item status as required fields or optional fields, or excluded from processing in certain organizational areas.



You can use these indicators to restrict the selection of items for BOM explosion.

- **Indicator: item relevant to engineering/design**
The item contains technical data that is important for development and design.
 - **Indicator: item relevant to production**
The item contains data that is important for the production of the assembly. For this reason, items with this indicator are copied to the planned order. The system determines dependent requirements for these items. You can maintain an *Issue location* for items that have this indicator.
 - **Indicator: item relevant to plant maintenance**
The item contains data that is important for plant maintenance tasks. This indicator is used in plant maintenance BOMs (material BOMs that are relevant to plant maintenance, equipment BOMs, and functional location BOMs).
You can maintain an additional field for the item (*PM assembly indicator* on the *Detail Screen: Status/long text*).
 - **Spare part indicator**
This indicator identifies the item as a spare part for the product.
In Customizing for *Production*, you define the spare part indicators by choosing *Bill of Material* → *Item Data* → *Define spare part indicators*.
You can allocate spare parts to different spare part indicators according to your own criteria. You could, for example, use the machine runtime between replacement of parts as a criterion.
- 

Spare part indicator **A** is for spare parts which must be replaced after a machine runtime of 100 hours.

Spare part indicator **B** is for spare parts which must be replaced after a machine runtime of 500 hours.
- **Indicator: item relevant to sales & distribution**
The item is relevant to sales orders. When you explode the BOM in a sales order, you only see the items for which this indicator is set.

Item Status

- **Indicator: item relevant to costing**

You use this key to define whether and to what extent the item is used in product costing. Planned manufacturing costs and the cost of goods sold can be determined from this and predefined costing variants, and saved as cost components.

Additional Data for the Item

Additional Data for the Item

You can enter additional data that controls specific business activities, such as the *Material provision* indicator.

Material provision indicator

This identifies the item as provided either *by a customer* or *by a vendor*.

In Customizing, you define who provides the item for each material provision indicator by choosing *Bill of Material* → *Item Data* → *Define material provision indicators*. You set either the *Material to be provided by customer* indicator or the *Material to be provided by vendor* indicator.

In material requirements planning (MRP), the system reads the material provision indicator. In BOM reporting functions, you can use this indicator as a selection criterion.

Material Provided by Vendor

In Customizing, you define *Material to be provided by vendor* indicators by choosing *Bill of Material* → *Item Data* → *Define material provision indicators*.



Only maintain this indicator for the BOM component if the material master record of the header material supports subcontracting (MRP data, field *Special procurement*). The special procurement key *Subcontracting* means that all components of the BOM are provided to the vendor for further processing. The items are copied to a subcontracting order.

The BOM for a material defined for subcontracting can contain the following items:

- Items to be provided to the vendor must **not** contain the *Material to be provided by vendor* indicator.
Dependent requirements are generated for these items.
These items are in the subcontracting order as materials to be provided. Goods issue can be planned in advance using a reservation. In inventory management, a transfer posting is made for these components from unrestricted-use stock to vendor stock.
- Items that are already on the vendor's premises and that your company does not need to provide have the *Material to be provided by vendor* indicator.
No dependent requirements are generated for these items.

Subcontracting and Production Versions

When processing a purchase document item (type *subcontracting*), the system determines the material BOM in accordance with the vendor you want to order from. These BOM versions of a material are stored in the material master as *production versions*.

Individual production versions are linked to suppliers either in the quota arrangement or in the purchasing info record.



You order material M1 as item 10 of a subcontracting order. Different BOM versions are defined for this material, depending on whether you order the material from vendor X in the US or vendor Y in Japan.

Additional Data for the Item

Subcontracting vendor X in the US has almost all components in stock, and these meet the required standard, so the BOM contains only 1 component. However, if you order from subcontracting vendor Y in Japan, you must provide 4 components, because this vendor's components do not meet the standard for material M1.

Material Provided by Customer

In Customizing for Production, you define *Material to be provided by customer* indicators by choosing *Bill of Material* → *Item Data* → *Define material provision indicators*.

This provision indicator has no control functions.

Bulk material indicator

A bulk material is a material component to which you have direct access at the work center (a loose material, such as grease or washers). You can enter the *bulk material* indicator in the material master record and the BOM item.

If a material is defined as a bulk material, dependent requirements for this material are not relevant to MRP. MRP for bulk materials is based on consumption.

Indicator in the material master record

You can define a material as a bulk material in the MRP data of the material master record.

If you set the bulk material indicator in the material master record, the system sets the *bulk material in material master* indicator in the BOM.

Indicator in the BOM

- This indicator is only supported for items that are relevant to production and/or plant maintenance.
- The item cannot be relevant to costing.
- You cannot enter an *production storage location* for bulk materials.

The indicator in the material master overrides the indicator in the BOM item. An indicator in the BOM item tells you whether the material is defined as a bulk material in the material master.

- If a material is **always** used as a bulk material, set the *bulk material* indicator in the material master record.
- If a material is only **sometimes** used as a bulk material, set the *bulk material* indicator in the BOM item.

If the BOM is only allocated to one plant, you see the default value from the material master record in this plant when you create an item.

Production Storage Location

This storage location is for issuing the material during the production process. A production storage location supports backflushing. This means that a goods issue for the material is posted automatically when you post the production order to stock.

The issue location in the item is displayed in the production order as a default.

When you enter a BOM item, the system checks whether the material is defined for the chosen plant and storage location.

Additional Data for the Item

You can only maintain a production storage location for material items that are relevant to production and/or plant maintenance. If an item that is relevant to production is defined as a bulk material, you cannot make an entry for the production storage location.

For production purposes, the storage location in the BOM item overrides the storage location in the material master. If you have not entered a production storage location in the BOM item, the system uses the value from the material master.

Supply Area

The supply area is used for supplying materials in the production area itself. You must enter the relevant production storage location.

Item Text

- **Item text**

For each item, you can enter a two-line text of 80 characters. This is stored in the BOM item (*Status/Long text* screen).

- **Long text**

If the item text is not sufficient, you can also click on  to enter a long text. The system copies the first 80 characters of the item text to the long text. If you change the BOM item text, and there is an item long text, the first 80 characters of the long text are changed automatically.

If the long text contains more than 80 characters, the system saves the long text to the text database.

PM Assemblies

PM Assemblies

You can only set the PM assembly indicator if the item is defined as relevant to Plant Maintenance (PM).

Items which have the PM assembly indicator are displayed as structure elements of an engineering system when you process maintenance tasks. You can use these structure elements to describe an item in more detail in the engineering system (for example, potential damage location).

When you maintain PM assemblies in BOMs that are relevant to PM, the system checks the component. You can only maintain this field if the BOM component is a material.



In BOM reporting functions, you can select items that are relevant to plant maintenance and that are defined as PM assemblies. However, PM assemblies are not exploded down further.

Administrative Data

On the *Detail Screen: Administrative Data*, you maintain the data concerning the validity period of the item within the BOM.

There are two sections for administrative data: *administrative data* and *validity data*.

Administrative Data

The system displays the actual date on which the item was created in the *Created on* field. If the item has been changed, the system displays the date on which the change was made in the *Changed on* field.

The administrative data also tells you which user processed the item.

Validity

- *Valid from* and *Valid to* date

In the standard R/3 System, you see this data if the item has been changed using a change number with a *Valid from* date validity.

- The *Valid from* date is taken from the change master record.
- The *Valid to* date tells you when the processing version shown is valid to. This date is taken from the change master record of the next validity period.

- *Change number* and *Change number to*

- The change number shows which change master record was used to create the processing version.
- If the item has a subsequent validity period controlled by a change number, you see this number in the *Change number to* field.

- Validity type

You see the validity type if the item has been changed using a change number with a new validity type (for example, validity by serial number).

Variable-Size Item Data

Variable-Size Item Data

On the *Variable-Size Item Data* screen, you maintain data that is specific to variable-size items.

If you enter variable-size item data, the system calculates the quantity. All calculations in BOMs are based on the international system of units.

This is the data you can maintain specifically for variable-size items:

- Size (1 to 3)

These three fields contain the dimensions of the variable-size item. The system uses these dimensions as variables in the selected formula to calculate the variable-size item quantity.

- Size unit

This field describes the unit for sizes 1 to 3.

If you do not enter a unit for variable-size item sizes 1 to 3, the system uses the default unit of measure that you defined when you configured your system.

The dimension of the size unit and the dimension of the unit of the variable-size item quantity are related (see the example below).



The following table contains the variable-size item data used to calculate the quantity for a sheet of metal.

Variable-Size Item Data for a Sheet of Metal

Size	Dimension	Entry	Size unit
1	Length	200	MM
2	Width	300	MM

If you do not enter a formula, the system calculates the quantity for the variable-size item according to the standard formula:

$$\text{Size 1} * \text{Size 2}$$

The result has the dimension *area*:

$$200 \text{ MM} * 300 \text{ MM} = 60,000 \text{ MM}^2 \text{ (square millimeters)}$$

The variable-size item unit must have the dimension *area* (MM2, CM2, or M2) or you must maintain conversion factors in the material master record.

- Formula key

This key represents the algorithm for calculating the variable-size item quantity. In Customizing for *Production*, you can define formulas by choosing *Bill of Material* → *Item Data* → *Define formulas for variable-size items*. You can also use the formulas defined in the standard R/3 System.

You can enter units of measure for calculating the variable-size item quantity with a formula. The calculation always uses unit for the dimension from the international system

Variable-Size Item Data

of units (for example, M3 for a volume in cubic meters). These units are defined in Customizing (dimensions for units of measurement).

- Number

This entry is the number of pieces of the variable-size item required for the assembly. This entry is used for calculating raw material requirements.

The unit PC (piece) is defined as a default in the standard R/3 System, in Customizing for Production, under *Bill of Material* → *Control Data for Bills of Material* → *Define modification parameters*.

- Variable-size item quantity

The system uses the sizes you enter and a variable-size item formula to calculate the quantity of the variable-size item.

If you do not enter a formula, the variable-size item quantity is either the product of sizes 1 and 2 (for dimension *area*) or the product of sizes 1, 2, and 3 (for dimension *volume*).

The variable-size item quantity is used for calculating raw material requirements:

Raw material requirement =	$\text{Number of variable-size items} * \text{Variable-size item quantity} * \text{Required quantity}$ <hr style="border-top: 1px dashed black;"/> Base quantity
----------------------------------	---

- **Component Unit of Measure for Variable-Size Item**

- This unit describes the unit of measure for the quantity of a variable-size item.
- In the material master record, you can enter alternative units to the base unit of measure. The only alternative unit used in BOMs is the unit of issue.
- Possible values are:
 - *Base unit of measure*
 - *Unit of issue*
 - Units of measure that have the same dimension as the base unit of measure or the unit of issue
- If you do **not** enter a unit, the system proposes a unit from the material master record, if the item has a material master record.
If a unit of issue is entered on the storage screen of the material master, the system copies this unit to the BOM. Otherwise, the system copies the base unit of measure to the BOM.

Purchasing Data

Purchasing Data

Bills of material can also include materials that are not kept in stock. These are generally procured externally and have the item category *non-stock item* (whether or not the component has a material master record).

You must maintain purchasing data for these BOM items, to ensure that the material is available in sufficient quantity on a certain date. You maintain this data on the *Detail Screen: Purchasing Data*.

The purchasing data that you can maintain for non-stock items is described below.

- **Purchasing group**

This key shows the buyer or purchasing group responsible for certain purchasing activities.

During a planning run, you can assign order proposals for an externally procured material to the appropriate purchasing group.

If the BOM is allocated to only one plant, and the non-stock item has a material master record, the system takes the purchasing group from the material master record as a default.

This field is for a standard non-stock item.

- **Vendor**

This number is unique and identifies a vendor in the R/3 System.

When you explode the BOM component, the system creates a purchase requisition for the vendor required.

- **Delivery time in days**

The delivery time (in days) for the material is required so that the system can determine the purchase order date.

If the BOM is allocated to only one plant, and the non-stock item has a material master record, the system takes the delivery time from the material master record as a default.

Purchase order date = Requirements date – Delivery time

- **Material group**

You can use the material group to group together several materials with the same characteristics. The system needs this field to create the purchase requisition, so it is defined as a required field.

If the BOM is allocated to only one plant, and the non-stock item has a material master record, the system takes the material group from the material master record as a default.

- **GR processing time**

The value you enter here is the time period (number of working days) after goods receipt (GR) that you need to check the material and place it in storage. This value is used in scheduling, for example, to determine the start and finish date for orders or operations.

If the BOM is allocated to only one plant, and the non-stock item has a material master record, the system takes the GR processing time from the material master record as a default.

- Price

This field contains the amount which is used in costing for pricing the product or assembly.

For non-stock items which are relevant to production and costing, the fields for price data are defined as required fields.

The price in the purchase requisition is used to determine the release strategy. If you do not enter a price for the non-stock item, the release strategy for a price of 0 is used.

The default price which appears does not depend on the price control indicator.

If the BOM is allocated to only one plant, and the non-stock item has a material master record, the system takes the price from the material master record as a default.

- Currency

The system determines the local currency of the initial plant (for example, US\$).

- Price unit

This field contains the number of the units of measure to which the price refers (for example, 120 gallons of gasoline cost \$150.00).

If the non-stock item has a material master, the default is taken from the material master. Otherwise, the default value is 1.

- Cost element

Each cost posted is allocated to exactly one cost element. Primary cost elements (material costs for external procurement) are distinguished from secondary cost elements (internal services or parts produced in-house). Primary cost elements are maintained as part of the G/L account master record and secondary cost elements are maintained in costing.

This field contains the consumption account which is to be debited with the goods issue.

The system checks whether the G/L account entered exists in the company code (plant). The system uses the plant you enter to determine the valuation area, then the company code.

This entry is used in various application areas:

- in MRP for purchase requisitions
- in costing for pricing



You must maintain a cost element for items that are relevant to costing.

Document Assignments

Document Assignments

Use

This function enables you to assign one or more documents to a BOM item or a BOM header. In this way, you can quickly access documents and display the originals when you process a BOM.



If, for example, you assign the design drawing of the appropriate components to each item, when you process the BOM you can immediately view the drawing for the specific component.

Furthermore, the assignment of documents to BOM headers and items is a prerequisite for Digital Mock-Up Viewing.

Prerequisites

In Customizing the document management (*Define document type* → [Determine object link \[Ext.\]](#)), you define with which BOM headers and items the document type can be linked.

See also:

[Object Links \[Ext.\]](#)

Features

You can assign a document to a BOM header or item. On the header detail screen and the item detail screen of each item there is a tab page with a list of the assigned documents. In this list, you can:

- Assign documents
- Delete document assignments
- Look for documents
- Sort the list in ascending or descending order
- Go to document info records
- Display and print out original documents
- Add notes

Digital Mock-Up Viewing

Document assignment is a prerequisite for Digital Mock-Up Viewing. If you want to view the 3D model of an assembly in the Engineering Workbench, document info records for the 3D models of the appropriate components have to be assigned to the BOM items. If you work with the CAD interface and you have set the parameters for Digital Mock-Up Viewing, the system automatically carries out the assignments.

See also:

[Digital Mock-Up Viewing \[Ext.\]](#)

Constraints

Document assignment is only supported for material BOMs and order BOMs.

Activities

You can assign a document to a BOM header or item:

You are in the header detail screen or in an item detail screen of a material BOM.

2. Choose the *Document assignment* tab page.
3. On an empty line, enter the document type and the document number as well as the document part ID and version number.
4. Save.

Detail Screens for a Class Item

Detail Screens for a Class Item

If the header material of a BOM has a material type which supports configuration, you can enter a class in the BOM as a *Class item*. See [Class Items \[Page 134\]](#).

When you create a class item, you enter a class type to define the reference to an object (material master or document info record). You also enter a *Resulting item category* for a class item (for example, variable-size item) to control the screen sequence and structure (for example, whether you see the *Detail Screen: Variable-size item data* for a material item). You see these fields for class items on all detail screens, in the *Item data* dataset.

The following two detail screens are relevant to class items:

- [Class Data \[Page 209\]](#)
- [Class Recursiveness \[Page 211\]](#)

Class Data

You maintain the *Detail screen: Class Data* for **all** classes that you enter as class items in a configurable BOM.

If you want to use a class as a component in a BOM, you can enter default values for this detail screen in the *Additional data* of the class.

Required component

You use this indicator to define that an object from the class must be selected when you configure the BOM.

Multiple selection

You use this indicator to define that several objects from the class can be selected as items when you configure the BOM.

Organizational area

This field shows the *organizational area(s)* maintained in the class on the *Detail Screen: Basic data*. The following sections tell you how these values are determined.

- **Class type**

In Customizing for *Cross-Application Components*, you define to which organizational areas each class type is relevant by choosing *Classification System* → *Classes* → *Object types* → *Class types* → *Settings for class maintenance* → *Maintain class types*.

- **Class**

The class that you enter as a class item can be relevant to one organizational area within a company, more than one, or all organizational areas (for example, design and production). In Customizing for *Cross-Application Components*, you define these organizational areas by choosing *Classification System* → *Classes* → *Object types* → *Class types* → *Settings for class maintenance* → *Maintain organizational areas*. You can select organizational areas on the *Detail Screen: Basic data* in the *Organizational area* field.

- You can select organizational areas for each individual characteristic of a class on the *Detail Screen: Characteristics*. The organizational areas that are maintained for the class in the basic data are displayed in a possible entries list. For example, some characteristics are only relevant to design, others are only relevant to production, and others are relevant to both.



In the configuration profile, you can define that only characteristics with selected organizational areas are displayed when the BOM is configured, and that values can only be assigned to these characteristics.

- For a class which supports class items in BOMs, you can restrict the organizational areas to one organizational area (such as design) on the *Detail Screen: Additional data*. When you configure the BOM, values are only assigned to the characteristics which are relevant to this organizational area (for example, design).

Class Data

This value is copied to the BOM processing function as a default value. You can overwrite this value with any organizational area that you selected on the *Detail Screen: Basic data* of the class.



If you did not select any organizational areas in the basic data for the class, you **cannot** restrict the organizational areas in the BOM. If you have not restricted the organizational areas in the BOM, you must assign values to **all** characteristics of the class when you configure the BOM.

Class Recursiveness

The *Detail Screen: Class Recursiveness* is only relevant to class items whose class type is linked to the material master. Here, you control the recursiveness check for a class item. For other item categories, you maintain this data on the *Detail Screen: General data*.

On the *Detail Screen: Class Recursiveness*, the system lists all objects which are allocated to the class entered as a class item. If this class has a class allocated to it, and this subordinate class also has materials allocated to it, these materials are also displayed on this detail screen.



If the class used as a class item is part of a class hierarchy, the hierarchy is exploded down to the lowest level.

See also:

[Recursiveness Check \[Page 164\]](#)

When does the system recognize class recursiveness?

The system recognizes recursiveness for a class item if the following objects are allocated to the class in the class item:

- The BOM header material
- A material with a BOM which contains the BOM header material as an item
- A class to which one of the materials described above is allocated



The recursiveness check includes all BOMs in a BOM group.

Fields for the recursiveness check

For class recursiveness, you maintain the following fields in the *Recursiveness* dataset:

- **Selection indicator (S)**

The system uses this indicator to select the components that cause recursiveness and for which you need to define the recursiveness check.

- **Component**

This field contains the material number of a component if:

- The component is allocated to the class entered as an item
- The component is allocated to a class in the class hierarchy that is below the class entered as an item

- **Class**

In this field, you see the class type and the class to which the component is allocated.

If this class is the same as the class in the class item, the material is allocated directly to this class. Otherwise, this class is allocated to a class in the class hierarchy that is below the class entered as an item.

Class Recursiveness

- **Indicator: BOM is recursive (Rec)**

The system automatically sets this indicator when it recognizes recursiveness.

- **Allowed**

If you enter a class as a class item and at least one material allocated to the class causes recursiveness, you see the *Detail Screen: Class Recursiveness*. In the first line, you see the first material that causes recursiveness. You must decide whether recursiveness is allowed for this material.

If you set this indicator for one of more of the selected components, the system returns to the *Detail Screen: New Material Items*. You can then continue processing.

Before You Create a Simple Material BOM

When you first create a BOM for a material, it is a simple material BOM. You can extend the BOM at any time to make it a variant BOM or a multiple BOM.

To ensure that you can enter all the data you require for the BOM quickly and easily, you should establish the following points before you start:

- Does a material master record exist for the material for which you want to create a BOM?
- Which usage do you want for your BOM?
Do you usually process BOMs with one specific usage? If so, you can define a default value.
- Can you use the material type of the header material with the usage you require?
- What area of validity do you want for your BOM?
- What validity period do you want for your BOM?
- Do you want to create a BOM that is subject to engineering change management? If so, which change number do you want to use?
- Do you want to assign a name to the BOM group? Which convention do you want to use?

User-Specific Settings

User-Specific Settings

You can define user-specific settings in various processing situations. User-specific settings are all stored in the same table, regardless of the function in which you define them.

You have the following options for defining user-specific settings:

- In Customizing for *Production*, you can define user-specific settings by choosing *Bill of Material* → *Define user-specific settings*.
- [Defining User-Specific Settings in the BOM Menu \[Page 215\]](#)
- [Defining Default Values as SET/GET Parameters \[Page 217\]](#)

Defining User-Specific Settings in the BOM Menu

You can define user-specific default values in the SAP Easy Access menu as well as in the initial screen of the BOM processing functions. The system saves only **one** default value per user and per field.

Settings in the SAP Easy Access Menu

Choose *Logistics* → *Production* → *Master data* → *Bills of material* → *Bill of material* → *Current Settings* → *User-Specific Settings*. In this menu path call up a Customizing step in which you can enter the user-specific default values.

Settings in the BOM Menu

In the entry screen for BOM processing functions you can enter user-specific default values via the *Settings* menu. Some settings are not relevant to all BOM categories (for example, *Material provision indicator*).

To Update User-Specific Settings in the Menu:

Choose *Settings*, then one of the following functions. Save each setting you define.

- *Material provision indicator*
 In this field, you enter the default value for the material provision indicator. These values were defined when you configured your system.
- *Item category*
 You can define a default value for material items, document items, and class items. The system checks the object linked to the item. For material items, for example, you cannot enter the default item category *Document item*.

 In the standard R/3 System, there is only one item category for document items and only one item category for class items (*Document item – D* and *Class item – K*).
- *PM assembly*
 This indicator defines an item as a PM assembly and is only relevant to plant maintenance BOMs. This indicator is displayed on the *Status/long text* detail screen of plant maintenance BOMs.
- *Item increment*
 In this field, you enter the default value for the item increment. When you maintain a BOM, the system increases the item number step by step by this amount.

Possible Settings for the Item Increment

Increment	Setting
10	None (standard)
Specific setting (such as 15)	<increment> (such as 0015)
No value – always 0000	0000

Defining User-Specific Settings in the BOM Menu

No value – always blank	----
-------------------------	------

Defining Default Values as SET/GET Parameters

Use

You can define default values for *BOM usage* and *BOM application* in your user master record. These are defined as SET/GET parameters. When you first call a BOM processing function, you see the default value from this setting. Then you always see the BOM usage or application you last entered.

Procedure

To define default values in a user master record:

1. Select *System* → *User defaults* → *Personal data*.
The *Maintain individual user defaults* screen appears.
2. Choose the *Parameter* tab page.
3. Enter the parameter ID and the parameter value:
 - CSA (BOM application)
 - CSG (BOM group)
 - CSV (BOM usage)
4. Save your settings.

Steps in Creating a Simple Material BOM

Steps in Creating a Simple Material BOM

When you create a simple material BOM, you carry out the following steps:

[Maintaining the Create Material BOM Initial Screen \[Page 219\]](#)

[Creating New Items \[Page 327\]](#)

[Adding Items to a BOM \[Page 227\]](#)

[Extending Item Data \[Page 229\]](#)

[Allocating a Component to an Operation \[Page 236\]](#)

[Classifying an Item \[Page 237\]](#)

[Entering Sub-Items \[Page 329\]](#)

[Maintaining Header Data \[Page 239\]](#)

[Defining the Technical Type \[Page 240\]](#)

[Checking and Saving Data \[Page 232\]](#)

See also:

[Maintaining a Configurable BOM \[Page 279\]](#)

Maintaining the *Create Material BOM* Initial Screen

1. In the SAP Easy Access Menu choose *Logistics* → *Production* → *Master Data* → *Bills of Material* → *Bill of material* → *Material BOM* → *Create*.

The *Create Material BOM: initial screen* screen appears. On this screen, you maintain data that identifies the bill of material, as well effectivity data.
2. In the *Material* field, enter the material for which you want to create the BOM.
 - If you do not know the material number, you can look for the material using the entry help (F4).
 - If the material for which you want to create a BOM has a material type that cannot be used in combination with the BOM usage you have entered, you see an error message.

See [BOM Usage and Material Type \[Page 46\]](#)
3. Enter a *Plant*.
 - If you want the BOM to be effective in a specific plant, enter the plant. You can allocate the BOM to additional plants later on under certain circumstances (*Create allocation of BOM to plant*).
 - If you want to create a group BOM, do not enter a plant.
4. Enter a usage.

If a parameter is defined in your user master record as a default value for the *Usage* field, the system enters this default.

When you select a BOM usage, you define the maximum range of item statuses that can be assigned to all items in the BOM. For each usage, you can only maintain certain item status indicators.

See [Defining the Item Status with the BOM Usage \[Page 44\]](#).



You cannot change the usage at a later date. However, you can create other BOMs for the material (in the selected plant) with different usages.
5. The *Alternative* field is used to identify one BOM in a BOM group (multiple BOM).



When you create a simple BOM, you do not need to enter an alternative.

 - If you do not make an entry when you first create a BOM, the system automatically creates alternative 01.
 - If you already know when you first create a BOM that you want to extend the BOM to make a multiple BOM, and that this alternative is not alternative 01, enter an alphanumeric value.

Maintain the data on the effectivity period:
6. Enter a change number if required.

Maintaining the Create Material BOM Initial Screen

- If you want to create the BOM **without a change number**, do not make an entry in the *Change number* field. Enter the date on which the BOM is to become valid in the system in the *Valid from* field.
- Enter a *Change number* if you want the BOM to have a **history requirement** as soon as it is created. If you enter a change number, you must enter a valid change number each time you want to change or extend the BOM. Usually, you only process a BOM with a change number once the BOM has been released for production.

See [Change Master Record \[Page 312\]](#)



When you select a change number, you need to consider the following points:

- Which object types (for example, BOMs or task lists) can be processed with this change number
- Which effectivity period will the change number give the BOM (valid-from date)
- The reason for the change

The system copies the valid-from date from the change master record into the *Valid from* field.

7. You may want to assign a revision level to a specific stage of development of the material for which you want to create a BOM. This revision level is assigned with reference to a change number.

- If you want to create a BOM for the material at a certain revision level, enter the revision level. If you display the possible entries, you see a list of all revision levels for the material. The change numbers with their valid-from dates are assigned to these revision levels.
- Copy the revision level you require by double clicking.

The system enters the valid-from date from the change master record in the *Valid from* field.

8. Confirm your entries by clicking .

The system makes a series of checks. For example, the system checks whether the material master record exists in the selected plant and whether the material type can be used in combination with the BOM usage.

When all data is correct, you goto the item overview of the BOM.

Creating New Items

You create new items in the item overview. The system automatically proposes existing item numbers.

If not enough empty lines are displayed for the new items, select *New Entries*.

The relevant data for the item categories is displayed on different tab pages for materials, documents and classes (only configurable BOMs).

On this screen, you can perform the following functions:

- [Entering Material Items \[Page 224\]](#)
- [Entering Document Items \[Page 225\]](#)
- [Entering Class Items \[Page 226\]](#)
- Entering [Text Items \[Page 136\]](#)

See also:

[Prerequisites for Item Entry \[Page 222\]](#)

[Identifying BOM Items \[Page 140\]](#)

Before You Create New Items

Before You Create New Items

Before you can enter a BOM item, certain requirements must be met.

Entering Material Components

Before you can enter material components, the following requirements must be met:

- A material master record exists in the system.
This does not apply to non-stock items without reference to a material master record, or to intra materials.
- If you create a material BOM with reference to a specific plant, all the material components of the BOM have plant data for the selected plant.



If the BOM is for plant maintenance purposes only, the system does not check for plant data, so you can create a BOM for a material with reference to a plant, even if no plant data is maintained for the material.

- The material type of the item is allowed in combination with the material type of the BOM header and the usage.
- In the material master record, you can maintain alternative units of measure to the base unit of measure.
In BOMs, only the base unit of measure and the unit of issue are used.



If you do **not** enter a unit for an item with a material master record, the system enters a unit from the material master record:

If a unit of issue is entered on the *Work scheduling 1* screen or the *Storage* screen, the system uses this unit. Otherwise, the system uses the base unit of measure.

For non-stock items without a material master record, the system proposes the component unit of measure PC (piece).

- If you enter a cost element for a non-stock item, you must enter a G/L account that has been defined for the company code.

See [Item Categories for Material Items \[Page 127\]](#).

Entering Document Items

Before you can enter document items, the document must have a document info record. The document must not be marked for deletion.

See [Document Item \[Page 133\]](#).

Entering Class Items

Before you can enter a class item, the class must exist in the system. For a configurable BOM, the class type must be defined for configurable objects (for example, 200 – configurable materials, 201 – configurable documents).

See [Class Item \[Page 134\]](#).

Before You Create New Items

In the additional data of class maintenance functions, there are several fields that control the use of the class in BOMs.

- The *Allowed in BOMs* indicator must be set before you can enter a class as a class item.
- Other additional data is also copied from class maintenance functions as default values. You can change this data for each BOM individually.

See [Class Data \[Page 209\]](#).

- The unit of measure entered in the additional data of the class maintenance function **cannot** be changed in the BOM. However, you can enter a unit with the same dimension.



You enter the unit of measure *meter* (dimension *length*) in class maintenance. When you enter the class as a class item in a BOM, you can also enter the units of measure *millimeter* or *centimeter* (also dimension *length*) in the BOM item.

Creating Material Items

Creating Material Items

To enter a material item:

1. Select the tab page *Material* on the item overview.
2. Enter an *Item category*.



Once you have entered and confirmed an item, you can no longer change the item category for the component. If you enter an incorrect item category, delete the item, and then enter it again with the correct item category.

3. Enter the material in the *Component* field.
4. Enter the *Quantity*. Enter the *Unit of measure* if you need to. You must enter a quantity for a material item.
5. Confirm your entries. The system checks your entries.

The new item is not created until you have entered **all** the required data for the item. The required data is different for each item category. For example, for a variable-size item you must enter sizes, and for a non-stock item you must enter a material group.

If the system recognizes that an entry is missing or incorrect, it displays the corresponding item detail screen. You can add the missing entries or correct the incorrect entries on this screen.

See also:

[Tab Page in the Item Detail Screen \[Page 138\]](#)

Entering Document Items

To enter a document item:

1. Select the tab page *Document* on the item overview.
2. Enter the item category for document items.



If you have defined a user-specific default value for the item category for documents in the settings for the item category, the *Ict (item category)* field contains this value. In the standard system, the item category *Document item* is defined for documents.

3. Make entries in the fields of the document key:
 - *Document number*
 - *Document type*
 - *Document part*
 - *Version*
4. Enter the *quantity*. You do not need to enter a unit of measure, because the system sets the value **piece** as a default.
5. Confirm your entries. The system checks your entries.

Entering Class Items

Entering Class Items

To enter a class item:

1. Select the tab page *Class* on the item overview.
2. Enter the item category for class items.



In the standard SAP System, the item category *Class item* is defined for classes. If you have defined a user-specific default value for the item category for classes, the *Ict (item category)* field contains this value.

3. Make entries in the fields that identify the class:
 - *Class types*
 - *Class*
4. Enter the *quantity*.
5. Enter a *unit of measure* if appropriate.

The system determines the unit of measure from the additional data of the class.

 - If a unit of measure without a dimension is maintained in the additional data of the class, you cannot change this unit.
 - If a unit of measure with a specific dimension (for example, length) is maintained in the additional data of the class, you can enter another unit of measure with the same dimension (for example, meter, centimeter, millimeter).
6. Confirm your entries. The system checks your entries.

For information on how to use a class item to select an object (material or document), refer to the section [Class item \[Page 134\]](#).

Adding Items to a BOM

Use

You can use this function to extend a BOM by adding items that are already contained in other BOMs. Once you have copied an item from the source BOM to the BOM you are processing, you can change the item data.

Procedure

How to extend a BOM:

You can see the item overview.

1. Choose *Edit* → *Extend...*

You see the *Extend...* dialog box. Enter the data of the BOM you want to copy.



You can only copy from a configurable BOM if the BOM you are processing is also configurable.

2. Confirm your entries.

If you are copying from a multiple BOM and have not entered an alternative in the *Extend...* dialog box, the system displays the alternative overview. Select an alternative as a template.

The *item overview* of the template BOM appears.

If you want to check all data for an item, select the item and click .

3. Select the items you want to copy.

4. Click  to copy all selected items.

The system copies the selected items from the source BOM to the BOM you are creating or changing.

The same checks are made as when you enter items manually. For example, the system checks for recursiveness.

If necessary, correct the copied item data.



The *Extend* function only copies the selected items in the BOM you are copying. If you do **not** select any items, you can return to the BOM you are processing by clicking . No data is copied to the new BOM.

5. If copied data is missing or incorrect, first you need to correct or complete the data. For this purpose, the system displays the relevant item detail screen. For example, the data transfer for recursiveness can take place (see the *Basic data* tab page, group frame *General data*).

Exiting the Item Entry Function

Exiting the Item Entry Function

1. If you have entered incorrect data for an item and want to exit the item entry for this one item, click .

You see the *Exit item editing* dialog box.

2. Confirm the query.

You return to the item overview.

Extending Item Data

Use

Sometimes the item data entered on the item overview is not sufficient. You need to enter more data for specific items.

Procedure

You can see the item overview.

1. Select the item(s) to which you want to add data.
2. Click .

The item detail screen of the first item selected appears.

3. Enter your item data.

By clicking on  and  you can flip between the detail screens of the selected items.

4. By clicking  you go back to the item overview.

Entering Sub-Items

Entering Sub-Items

Use





Sub-items are used to describe the different installation points of these partial quantities.

Prerequisites

In Customizing for *Bills of material* (work step *Item data* → *Define item categories*), you can define whether sub-items are supported for each individual item category. In the standard system, for example, sub-items are supported for the following item categories: Stock item Non-stock item Variable-size item PM structure element

Procedure

You can start the function for entering sub-items either from an item overview or from an item detail screen.

1. If you are on an *Item overview*, select the items for which you want to enter sub-items.
If you are on an item detail screen, start with step 2.
2. Click  *Subitem*.
You see the *Subitems* screen, on which sub-item numbers are already given.
3. Enter the subitems.
You can enter the following data:
 - *Installation points*
 - *Sub-item quantities*
The system compares the item quantity to the sum of all sub-item quantities. If the item quantity is different from the sum of the sub-item quantities, the system changes the item quantity.
You see the following information:
Item quantity changed from <old value> to <new value>
- *Sub-item description*
Enter a descriptive text for the sub-item (up to 40 characters).
4. If you have selected several items, you can switch between then sub-item overviews and the individual items using the  and  buttons.
5. Click .

Result

On the item overview, all the items that have sub-items have the *Sub-items exist (SIs)* indicator.

Once you have entered sub-items for an item, you can only change the component quantity on the sub-item overview.



No history is stored for sub-items. If a change to a sub-item quantity leads to a change to an item quantity, a new item record is created. The sub-items are maintained separately for each item record.

Checking and Saving Data

Checking and Saving Data

You can check all the data on one of the item overviews:

- *Material item overview*
- *Document item overview*
- *Class item overview*
- *General item overview*

How to check item data:

1. Choose *Goto* → *Item overview <object type>* or *General*.
2. Correct your data if required and confirm your changes.
3. Once you have finished entering your data, save the BOM.

You return to the initial screen. The system displays the following message:

BOM for material <material number> created

When you save a BOM, the system assigns an internal BOM number. When you process the BOM, the internal BOM number is displayed on each header detail screen.

Other Maintenance Functions

When you create a BOM, you can also use the following functions:

[Allocating a Component to an Operation \[Page 236\]](#)

[Classifying an Item \[Page 237\]](#)

[Maintaining Header Data \[Page 239\]](#)

[Defining the Technical Type \[Page 240\]](#)

Assignment to an Operation

Assignment to an Operation

The production processes for a product are described without reference to an order in routings. A routing contains the operations required in production, and the production resources/tools, material components, and test equipment required to produce the product.

When describing the production resources/tools used to produce a material, the work scheduler is supported by the assignment of BOM items to operations.

This assignment means that the BOM items or materials are not reserved until the start point of the operation. If you do not assign items to specific operations, the system automatically assigns all material components in a BOM to the first operation when the order is opened. This means that they are all made available at the start point of the first operation.

The following graphic shows the assignment of items to operations.

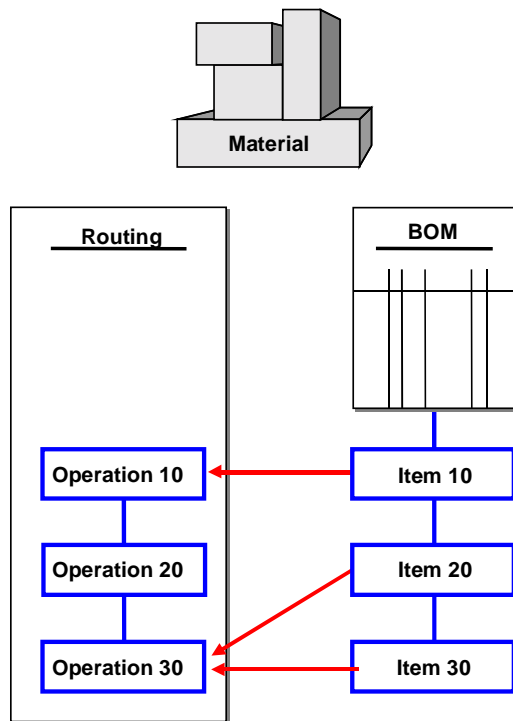

You can create the assignment from the following screens:

- *Material* item overview
- Item detail screen of a specific item that you want to assign to an operation.



The standard system does **not** support assignment to operations for the following item categories:

- Class item
- Document item
- Text item

Assignment to an Operation

- PM structure element

These items are deselected. The system displays a message telling you this.

Allocating a Component to an Operation

Allocating a Component to an Operation

To allocate a component to an operation:

1. Choose *Extras* → *Operation allocation*.
 - If **no routing** exists for the material, you see a dialog box in which you can decide whether to create a routing.
 - If you want to create a routing, confirm the query. You see the *Create routing: Initial screen*.

Enter the data you require and confirm your entries.
The system makes a series of checks. If all your data is correct, you see the *Header Detail* screen.

Enter the header data you require for your routing.
 - To enter operations, choose *Goto* → *Operation overview*.

Define the work centers for processing.

Confirm your entries. You may see specific detail screens for the work center, on which you must enter various data.

If your data is correct, you return to the *Operation overview*.
 - If a **routing** exists, you see the *Operation overview*.

If the selected BOM item has not yet been allocated to an operation, the *Allocation exists* indicator (at the end of a line containing an operation) is not selected for any operation.
2. Select the operation to which you want to allocate your material component.
3. Choose *New allocation*.

The system allocates the operation you selected to the item you selected and selects the *Allocation exists* indicator at the end of a line containing the operation.
4. In the *Material components* menu, you can display the *General data* and the *Administrative data* of the allocated material components.
5. Once you have allocated the item to an operation, go back to the *Material* item overview by choosing *Back*. You can either allocate another item to an operation or enter other BOM data.

Classifying an Item

You can classify any material item that has a material master. In the standard R/3 System, the following material items have a material master record:

- Stock item
- Non-stock item with a material master
- Variable-size item
- PM structure element
- Intra material

In the standard R/3 System, BOM items can be classified in classes of the following class types:

- 022 – Batch with plant
- 023 – Batch without plant

Class types 022 (Batch with Plant) and 023 (Batch Without Plant)

In classes of class types 022 and 023, you can classify multiple object types, such as BOM items, item data of sales documents, and item data of deliveries.

In Customizing for *Cross-Application Functions*, you define a hierarchy for these objects by choosing *Classification System* → *Classes* → *Object types* → *Class types* → *Maintain class types*. This hierarchy controls the way in which dependent objects inherit their characteristics. In classes of class types 022 and 023, batches and BOM items inherit their classification data from the corresponding materials.

Under each of these class types, you create one class with the characteristics whose values cause a BOM item to be selected. Multiple classification is not supported for these class types. This means you can allocate a material item to only one class of the class type.

In BOM maintenance, only one of these class types is available for classification. The system determines the class type in accordance with the batch level selected. In Customizing for *Logistics General*, you define the batch level under *Batch Management* → *Specify batch level and activate status management*.

The following table shows the relationship between the batch level and the class type determined in BOM maintenance.

Batch Level and Class Type

Batch level	Class type for BOM item	Identifying material data
Batch at plant level	022 – Batch with plant	Material Plant Batch
Batch at material level	023 – Batch without plant	Material Batch

Classifying an Item

Batch at client level for material	023 – Batch without plant	Material Batch
------------------------------------	----------------------------------	-------------------



In the standard R/3 System, the batch level is set to *Batch at plant level*. With this setting, you automatically classify your material items under class type 022 – Batch with plant.

If you change the batch level, you must then start a conversion program. For more information, refer to the Implementation Guide (IMG) for *Batch Management*.

To classify a material item:

You can call the *Classification* function from any item overview and any item detail screen.

1. If you are on an item overview, select the material item, then choose *Extras* → *Classification*.

If you are on an item detail screen, choose *Extras* → *Classification*.

You see the *Classification* screen. Depending on the batch level selected, the system presets 022 – Batch with plant or 023 – Batch without plant in the *Class type* field. You cannot change this value.

2. Assign the item to one class of this class type.
3. Assign values to the characteristics of the class.
4. Return to the item overview or to the item detail screen.

When you save the BOM, you automatically save the classification data.



Once you have classified a material item, you see the *Classification* pushbutton in the *BOM item* dataset of the *General Data* item detail screen.

Maintaining Header Data

For more information on the data fields in the BOM header, see [BOM header \[Page 48\]](#) **Error! No bookmark name given..**

How to maintain header data:

When you start the function for creating a BOM, the system copies certain data to the BOM header. You can enter additional header data at any time on the header detail screen.

1. Click .

You can enter additional data on the tab pages *Quantity/Long text* and *Additional data*. Furthermore, you can assign documents that are managed with the document management system (CA-DMS) to the BOM header on the tab page [Document assignment \[Page 206\]](#).

2. Enter your data.

- In the *BOM group* field, you can enter a name for the entire BOM group (all alternatives of a multiple BOM or all variants of a variant BOM). The system checks for special characters.
You can use the *Display BOM group* function to access the material BOM. As well as accessing the material BOM by entering the *Material/Plant/Usage*, you can access the BOM by entering the *BOM group*.
- When you maintain a simple BOM (the value for the technical type is blank), you do not see the fields for lot size, which are relevant to multiple BOMs, on the *Quantities/long text* header detail screen.



If you already know which technical type you want when you first create a BOM, you can define the first alternative immediately.

See also:

[Defining the technical type \[Page 240\]](#)

Defining the Technical Type

Defining the Technical Type

The system does not define the technical type automatically. First you must create an additional alternative for or a variant of an existing simple material BOM.

If you define a BOM as technical type "multiple BOM" when you first create a simple material BOM, you can maintain the lot-size fields.



Please note that you cannot change the technical type once you have set it.

How to define the technical type of a BOM:

1. Go to any header detail screen.
2. Choose *Edit* then *More* → *Define tech. type*.
3. You see a dialog box in which you enter the technical type.
4. Choose *Copy*.

You see the header screen from which you called the function again.



If you selected technical type "multiple BOM", you see the fields for lot size on the *Quantities/long text* header detail screen.

Creating a Material BOM for Additional Usages

Use

The different application areas within a company only process the item data that is relevant to their area. For this reason, you enter a BOM usage when you create a BOM. This usage defines which item statuses are allowed for all items in this BOM.

For example, if you create a BOM for the design department, data that is relevant to design is entered. Meanwhile, the sales department requires data that is relevant to sales and distribution. These two BOMs may contain different items. The system stores these different BOMs for a product under different internal BOM numbers.

Procedure

How to create a BOM for an additional usage:

1. Choose *Logistics* → *Production* → *Master data* → *Bills of material* → *Bill of material* → *Material BOM* → *Create*.
You see the *Create material BOM: Initial screen*.
2. Enter the following data:
 - *Material* (which already has a BOM for a different usage)
 - *Plant* (in which you want the BOM to be valid)
 - *Usage* (for which no BOM exists yet)
 - *Alternative* (if required)
 - Data to define the validity period
3. Confirm your entries.
The item overview appears.
4. Enter all the items you require.
5. Confirm your entries.
6. The BOM usage you selected may support some item status indicators as optional fields. If you want to process the indicator for several items, select these items and click .
- The item detail screen appears.
7. Choose the *Status/Long text* tab page.
See also:
[Status/Long Text \[Page 193\]](#)
 - Process the indicators for the item status and new item data, as required.
 - Confirm your entries.
8. Save your BOM.
You get the message:
BOM for material <material number> created

Creating a Material BOM for Additional Usages

The system assigns a new internal BOM number.

Creating a Material BOM with an Existing BOM

Use

A BOM may already exist in the system that contains some data that you want to copy to a new BOM you are creating.

You can copy an existing BOM.

Before You Create Your BOM

When you create a new BOM, you can copy a BOM that has the same usage or a BOM that has a different usage to the BOM you want to create.

Copy defaults

You defined the copy defaults when you configured your system. These copy defaults determine how the item statuses in an existing BOM are changed when the items are copied to a new BOM. The item statuses may be either extended or reduced.

When you copy BOM items from an existing BOM, the following rules apply:

- If there is an item status copy default for copying from one BOM usage to another, the copy default is used when you copy the items.
- If no copy default is defined, all indicators that are allowed in the BOM usage of the new BOM are copied when you copy the items.

Procedure

How to create a new BOM by copying from an existing BOM:

1. Choose *Logistics* → *Production* → *Master data* → *Bills of material* → *Bill of material* → *Material BOM* → *Create*.

You see the *Create material BOM*: Initial screen.

If a parameter is defined in your user master record as a default value for the *Usage* field, the system enters this parameter or the last usage entered as a default value for display.

2. Enter the data for the BOM you want to create.

If you want to check whether the BOM for the *Material/Plant/Usage* you entered already exists, choose .

If the check is successful, you see the description of the material from the material master record.

3. Enter the data of the BOM you want to copy as follows:

- a. Click .

You see the *Copy from* dialog box, in which you enter the data of the BOM you want to copy.

- b. Confirm your entries.



If the BOM you want to copy is a multiple BOM and you did not enter an alternative in the *Copy from...* dialog box, the system displays the alternative overview.

Creating a Material BOM with an Existing BOM

Select the alternative you require then choose *Copy from*.

- c. You see the item overview of the BOM you are copying.

If necessary check the items by clicking .

If you selected several items on the item overview, you can influence the order in which you process the selected items. To see the data for the next or previous item, choose  and .

To return to the item overview of the BOM you want to copy, click .

4. Copy the data of the source BOM:

- a. On the item overview of the source BOM, select the item(s) you want to copy.

- b. Click .

The system copies the header data and the items you selected from the source BOM to the new BOM you are creating.





The *Copy* function always copies the BOM header of the source BOM.

If you do not select any items, only the header is copied. In this case, the system displays an appropriate message.

If the data you copy is incorrect or some data is missing, you need to change or complete this data.

5. On the item overview of the new BOM you are creating, you can change or complete the data you copied.

In order to change or add data on the item detail screen select the item and click .

If you want to extend the header data click .

6. Once you have finished entering your data, save your BOM.

You return to the initial screen. The system displays the following message:

BOM for material <material number> created

When you save the BOM, the system assigns a new internal BOM number.

Creating a BOM by Copying an Existing BOM with a Different Usage

The usage of the BOM you are creating and the usage of the BOM you are copying from do not need to be the same. The item statuses of the copied item can be extended or reduced in the new BOM usage if a copy default is defined.



In Customizing for *Production*, you define copy defaults by choosing *Bill of Material* → *BOM Usage* → *Define copy default for item status*. These copy defaults determine how the item statuses in an existing BOM are changed when the items are copied to a new BOM.

Example of a copy default

You want to create a BOM with usage *Production* (1).

The item statuses are defined such that all items are relevant to production, and items can be relevant to design or spare parts.

You enter a BOM with usage *Engineering/design* (2) that you want to copy.

The item statuses are defined such that all items are relevant to design, and items can be relevant to production or spare parts (new usage 1; usage of source BOM 2).

- If you defined a **copy default** when you configured your system:
According to this copy default, the items you copy to the new BOM are marked as only relevant to production and design. All other indicators in the source item are ignored.
- If you did not define a **copy default** when you configured your system:

The items are copied to the new BOM as they are, insofar as this is possible.

As the *Indicator: item relevant to production* is a required entry in the new BOM with usage *Production* (1), and this indicator may not be maintained in all items in the source BOM with usage *Engineering/design* (2), you may need to enter the *Indicator: item relevant to production* manually.

Plant Allocations

Plant Allocations

You can extend the area of validity of a BOM that you defined when you first created the BOM. You can allocate the same BOM to a material in different plants. This avoids data redundancy and multiple data entry.

Before you can allocate a BOM to material in a different plant, certain conditions must be met (see [Area of Validity \[Page 30\]](#)).



On the initial screen for plant allocations, the entry in the *Plant* field has the following significance:

Special character "*" all plants
Blank group BOM

See also:

[Creating a Plant Allocation \[Page 247\]](#)

[Changing a Plant Allocation \[Page 249\]](#)

[Displaying a Plant Allocation \[Page 250\]](#)

Creating a Plant Allocation

Creating a Plant Allocation

To allocate a BOM to an additional plant:

1. From the bills of material menu, choose *Bills of material* → *Material BOM* → *Allocation to plant* → *Create*.

You see the initial screen for plant allocation.

2. Enter the data of the BOM you want to allocate to an additional plant.
 - *Material*
 - *Plant*
 - *Usage*
 - *Alternative*

You do not need to enter an alternative for a simple BOM.

If you do not enter an *Alternative* for a multiple BOM, you see the alternative overview. You can select one of the alternatives on the overview to allocate to one or more additional plants.

Choose *Edit* → *New allocations*.

3. In the *Material allocations – BOM* dataset, enter the plant to which you want to allocate the BOM.
 - If you do not make an entry here, you see a list of all the plants to which you can allocate the BOM.
 - Select the plants to which you want to allocate the BOM.
 - Choose *Edit* → *New allocations*.

You see the *Current allocations* screen. The system displays all the plants you selected for allocation on this screen.



If a BOM or alternative could **not** be allocated to a plant, you see an information message. The reasons why are documented in a log. Choose *Log*.

4. If your BOM is a multiple BOM, you can maintain the lot-size range for the individual allocations on the *Current allocations* screen.



If your BOM is a multiple BOM, the system copies the lot sizes from the plant to which the BOM was originally allocated. You can change these at any time.

5. Save the new allocations on the *Current allocations* screen.

The *Save* function automatically checks the allocations.

Creating a Plant Allocation

Checking Plant Allocations Before Saving

To check plant allocations:

- To check whether the current allocations are also possible at BOM item level, choose *Edit* → *Check allocations*. If not all allocations are possible, you see an information message. You can see the reason why in the log.
- To see the log, choose *Extras* → *Log*. You see information on why certain allocations cannot be made. For example, not all material components have material masters in the plant to which you want to allocate the BOM.



Before you can save your allocations, you must delete the allocations that cannot be made on the *Current allocations* screen.

Deleting Plant Allocations Before Saving

To delete a plant allocation:

1. Select the allocations you want to delete on the *Current allocations* screen.
2. Choose *Edit* → *Allocation* → *Delete*. Confirm the query.

Changing a Plant Allocation

How to change a plant allocation:

1. Choose *Bills of material* → *Material BOM* → *Allocation to plant* → *Change* from the bills of material menu.

You see the initial screen for plant allocation.

2. Enter the data of the BOM whose allocation to an additional plant you want to change.

- *Material*

- *Plant*

Enter the plant where the BOM you want to allocate to an additional plant is maintained.

- *Usage*

- *Alternative*

You do not need to enter an alternative for a simple BOM.

If you do not enter an *Alternative* for a multiple BOM, you go to the alternative overview. You can select one of the alternatives on the overview to allocate to one or more additional plants.

3. Confirm your entries. You see the *Current allocations* screen. The system displays all allocations of the current BOM to the plant you entered on this screen.

To identify the BOM, you see the internal BOM number and the usage.

- If you want to create a new plant allocation, choose *New allocations*.

- If you want to delete a plant allocation choose *All allocations*. Select the allocation you want to delete. Then choose *Edit* → *Delete allocation*.

Confirm the query. The system deletes the allocations you selected on the *All allocations* screen. Return to the *Current allocations* screen and save the plant allocations.

You return to the initial screen. The system displays the following message:

Plant allocations for <material> <plant> <usage> changed

Displaying a Plant Allocation

Displaying a Plant Allocation

How to display a plant allocation:

1. Choose *Bills of material* → *Material BOM* → *Allocation to plant* → *Display* from the bills of material menu.

You see the initial screen for plant allocation.

2. Enter the data of the BOM you want to allocate to an additional plant.

- *Material*
- *Plant*
- *Usage*
- *Alternative*

You do not need to enter an alternative for a simple BOM.

If you do not enter an *Alternative* for a multiple BOM, you go to the alternative overview. You can select one of the alternatives on the overview to allocate to one or more additional plants.

3. Confirm your entries. You see the *Display current allocations* screen. The system displays all allocations to the current BOM in the plant you entered on this screen.

To identify the BOM, you see the internal BOM number and the usage.

The *Material allocations – BOMs* dataset shows the following data:

- For a variant BOM, you see the variant with the material number and plant.
- For a multiple BOM, you see the alternative, material number, and plant. You also see the lot size fields.



For all BOMs, the system checks whether the material is a configured material (material variant). If it is, you see an indicator in the *Cfg. mat (Indicator: configured material)* field. Configured materials do not have their own BOM. They are allocated to the BOM of the configurable material.

4. To display all allocations for the BOM, choose *All allocs to BOM (All allocations to BOM)*. The display screen has the same format as the current allocations screen.
 - For a simple BOM, you see all plants in which the BOM was allocated to the selected material.
 - For a variant BOM, you see all variants with the material number and plant.
 - For a multiple BOM, you see all alternatives with the material number and plant.

If appropriate, the system sets the *Configured material* indicator.

Displaying a Material BOM

You use this function to display a material BOM (single-level) over a certain validity period.

See also:

[Before You Display a BOM \[Page 252\]](#)

[Validity Period \[Page 253\]](#)

[Required Quantity \[Page 254\]](#)

The SAP System also supports functions for displaying multi-level BOMs for various analytical tasks.

See also:

[Reporting Functions \[Page 353\]](#)

[Displaying One Variant BOM \[Page 292\]](#)

[Displaying One Alternative in a Multiple BOM \[Page 305\]](#)

Before You Display Your BOM

Before You Display Your BOM

To display the BOM with all the data you require, you need to establish the following:

- Do you want to display a specific alternative of a multiple BOM or a specific variant of a variant BOM, or the entire BOM group?
- Which validity period do you want to use for displaying the BOM?
- Which required quantity do you want the component quantities to refer to?

Validity Period

The system uses the validity period you enter for the BOM header to determine which items are valid. You can restrict the validity period for displaying the BOM.

On the initial screen, you can use the following four fields to define the validity period:

- Change number
- Valid-to date
- Valid-from date
- Revision level

The following table shows which entries you can make to define validity.

User Entries for Validity Period

Validity period required	Field	Description of user entries
<i>On the valid-from date of a change master record</i>	<i>Change number</i>	The date is copied from the change master record. All BOM data valid on the valid-from date of the change master record or on a specific alternative date in the change master record is displayed.
<i>On a specific date</i>	<i>Valid-from date</i>	Date on which you want to display the BOM
	<i>Valid-to date</i>	Same entry as <i>Valid-from date</i>
<i>Within a time period</i>	<i>Valid-from date</i>	Date at beginning of time period
	<i>Valid-to date</i>	Date at end of time period
<i>Over its entire validity period</i>	<i>Valid-from date</i>	Delete character “!” at beginning of field
	<i>Valid-to date</i>	No entry
<i>Up to a specific date</i>	<i>Valid-from date</i>	Delete character “!” at beginning of field
	<i>Valid-to date</i>	Date up to which you want to display the BOM
<i>At a specific revision level</i>	<i>Revision level</i>	Revision level assigned to a change with a change number. The system determines the <i>Valid-from date</i> from the assigned change master record.

Required Quantity

Required Quantity

In the *Required quantity* field, you can enter the quantity to which all component quantities displayed refer.

The component quantities are relative to the base quantity. The system uses the following calculation:

C o m p o n e n t q u a n t i t 	Required quantity * Stored component quantity
	----- Base quantity

Calculating the Component Quantity: Example

The following table shows an example calculation for calculating component quantities with reference to the required quantity.

Recalculation of Component Quantity for Assembly *Blue paint-01*

<i>Component</i>	Component quantity (liters)	Component Required quantity (30 liters)
	Base quantity (3 liters)	
Blue pigment	0.3	3.0
Solvent	1.2	12
Water	1.5	15

If you do not enter a required quantity, the component quantities displayed are based on the base quantity.



Items which have a component quantity defined as a *Fixed quantity* (*Detail screen: General data*) are not affected by the required quantity entered.

Calculating the Component Quantity: Example

Steps for Displaying a Simple Material BOM

Steps for Displaying a Simple Material BOM

Here you find the procedure for displaying material BOMs.

Maintaining the "Display Material BOM" Initial Screen

To display a material BOM, choose *Material BOM* → *Display* from the *Bills of Material* menu. You see the *Display Material BOM: Initial screen*. On this screen, you maintain data that identifies the bill of material, as well as data concerning the validity period.

How to display a material BOM:

1. From the *Bills of material* menu, choose *Bills of material* → *Material BOM* → *Display*.

You see the *Display Material BOM: Initial screen*.

- If a parameter is defined in your user master record as a default value for the *Usage* field, the system enters this parameter or the last usage entered as a default value for display.
- In the standard R/3 System, the default valid-from date and valid-to date are today's date.

2. Enter the data that identifies the BOM on the initial screen:

- In the *Material* field, enter the material whose BOM you want to display.
- Enter the plant for which you want to display the BOM. If you want to display a group BOM, do not make an entry in the *Plant* field.
- If there is no value or an incorrect default value in the *Usage* field, enter the usage for which you want to display the BOM.
- You do not need to make an entry in the *Alternative* field for a simple material BOM.

3. Define the validity period.

To do this, you can use the following fields: *Change number*, *Valid-from date*, *Valid-to date*, *Revision level*.

See also:

[Validity Period \[Page 253\]](#)

4. In the *Required quantity* field, enter the quantity to which you want all the component quantities to refer. The component quantities are calculated to match the required quantity. Component quantities which are defined as *fixed* quantities stay the same.

5. Confirm your entries.

The system makes a series of checks. It checks whether the BOM is valid in the validity period you entered.

If no items are valid in the validity period you enter, you see the BOM header data and the following message:

No items valid on <date>

If the data you entered is correct, you see the *Material item overview*.

Displaying Component Master Data

Displaying Component Master Data

For information on which master records are maintained for the different item categories, see the topic [Entering BOM Items \[Page 137\]](#).

See also:

[Displaying a Material \[Page 259\]](#)

[Displaying a Document \[Page 260\]](#)

[Displaying a Class \[Page 262\]](#)

Displaying a Material

You can display the material master record of a material component from all item overviews:

- *Material item overview*
- *Document item overview*
- *Class item overview*
- *General item overview*

To display material data:

1. Select the items whose material data you want to display.
2. Choose *Environment* → *Material* → *Display* → <view>.

You see the data you require from the material master record.

To see the material data of the **next** material you selected, choose *Back*.



You cannot return to the item overview until you have displayed the material data of **all** the materials you selected.

Displaying a Document

Displaying a Document

You can display the document info record of a document item from all item overviews:

- *Material item overview*
- *Document item overview*
- *Class item overview*
- *General item overview*

To display document data:

1. Select the items you want to display.
2. Choose *Environment* → *Document* → *Display*.

You see the basic data screen of the document info record.

To see the document data of the **next** document you selected, choose *Back*.



You cannot return to the item overview until you have displayed the document data of **all** the documents you selected.

Displaying originals

You use this function to display an original application file which is entered as file 1 or file 2 in the document info record. You can execute this function on one of the item overview screens or on a detail screen for a document item.



You can only display originals if certain technical conditions are fulfilled. For example, you must have access to the data carrier on which the original files are stored.

How to display an original application file on the *Document item overview*:

1. Place the cursor on a field of the document item.
2. Choose *Environment* → *Display original*.

If two original application files are linked to the document info record, you see the *Start display application* dialog box.

Select the *Application* field or on the *Data carrier* field. The system starts the application with the original application file you chose.

3. To exit processing, close the application window.

You can then continue processing on the item overview.

How to display an original application file on the other item overviews:

1. Select a field of the document item. You see the *General data* item detail screen.
2. Place the cursor on a field of the document item.
3. Choose *Environment* → *Display original*.

Displaying a Document

If two original application files are linked to the document info record, you see the *Start display application* dialog box.

Select the *Application* field or on the *Data carrier* field. The system starts the application with the original application file you chose.

Displaying a Class

Displaying a Class

You can display class data from all item overviews:

- *Material item overview*
- *Document item overview*
- *Class item overview*
- *General item overview*

To display class data:

1. Select the items you want to display.
2. Choose *Environment* → *Class* → *Display*.

You see the basic data screen of the class.

To see the class data of the **next** class you selected, choose *Back*.



You cannot return to the item overview until you have displayed the class data of **all** the classes you selected.

Displaying Item Data

Depending on the object concerned, the items and the identifying object data are displayed on different tab pages.

- *Material* tab page
Shows material items with the material number of the material master record.
- *Document* tab page
Shows documents with the key fields of the document info record (*Document number*, *Document type*, *Document part*, and *Document version*).
- *General* tab page
Shows all components with their key fields. The *OTp* (object type) field shows which object (material, document, or class) the component refers to.





In configurable BOMs, you can also display the *Class* tab page. The classes are identified by class name and class type.

To display item data:

1. In the item overview select one of the tab pages (such as Material).
2. Select the items for which you want to display data.
3. Click .

If you selected several items on the item overview, you can influence the order in which you process the selected items.

To display the data for the next or previous item, choose  and .

4. To return to the item overview, click .

See also:

[Item Detail Screens \[Page 138\]](#)

Displaying Effectivity Data for Items

Displaying Effectivity Data for Items

Use

Effectivity data shows the conditions under which an item is effective.

Procedure

Item with Date Effectivity

In the standard system, time effectivity is defined by the *Valid-from* and *Valid-to* dates. You can display this data directly from the item overview.

See also: [Validity Period \[Page 33\]](#)

Item with Parameter Effectivity

An item that has been changed with a change number whose effectivity is defined by an effectivity type (parameter effectivity), has no *Valid-from* or *Valid-to* date on the item overview.

You can only display the effectivity data indirectly, by displaying the change master record. By double-clicking on the field *Change number* in the change master record you go to the item overview.

See also: [Effectivity \[Page 35\]](#)

Filtering Items

On the item overviews, you can filter the items according to various criteria. To do this, enter a filter object in a dialog box or combine several filter criteria in a dynamic filter. All the items that do not match your filter criteria are filtered out of the item overviews.



The filter settings remain active only during the current BOM processing session. If you process the BOM again at a later date, you have to reset the filter.

To set filters, choose: *Edit* → *Filter*.

- If you filter according to object, only the items of one specific object type are displayed. To do this, select a *Filter* object:
 - *Material*
 - *Document*
 - *Class*
 - *Without object* (text item, for example)
- You can filter according to whether the item has *Object dependencies* or *Classification* data.
- If you filter according to *Item category*, only the items of one specific item category are displayed.

You enter the item category of the items you want to see in a dialog box.

Filtering Dynamically

If you want to combine filter criteria so that you see an even more precise selection of items, choose *Filter* → *Dynamic*.

Select the indicators for one or more datasets:

- Object filter
- *Item category filter*
- Classification filter
- Object dependencies filter



The filter settings remain active during the current BOM processing session. If you want to display an overview of all the valid items again, choose *Edit* → *Filter* → *Hide*.

Filtering by Effectivity

On the item overview the changes with all effectivity types are displayed in the standard system. With the effectivity filter, you can hide certain items. Further information on effectivity filters can be found under [Filtering Items According to Effectivity \[Page 267\]](#).

Filtering Items

Filtering Items According to Effectivity

Use

You can process items with a change number. A change number defines effectivity according to one of the following:

- *Valid-from* date
- Parameter effectivity (effectivity type)

On the item overview the changes with all effectivity types are displayed. With the effectivity filter, you can hide certain items.

Procedure

You can see the BOM in the item overview.

1. Click  *Effectivity*.

You see the *Effectivity filter* dialog box.

2. Enter the effectivity conditions.

You can determine the effectivity conditions on three tab pages:

- **Effectivity types**

Here you can set the selection indicator for the effectivity types. The system only displays the items that have been maintained with the selected effectivity types.

- **Effectivity parameters**

Here you can enter effectivity parameter values for the selected effectivity types in order to further restrict the selection. The system only displays the items that fulfil these values.

- **Release status**

Here you can set the selection indicator for the release status. The system only displays items whose release key is set for the selected release status.



By clicking  you can restore the standard settings with which **all** items are displayed.

3. Click .

Result

On the item overview, only items that are effective for the effectivity conditions you entered are displayed.

Sorting Items

Sorting Items

In the standard R/3 System, items are sorted in ascending order of item number. However, you can change this sort sequence while you are processing a BOM.



The sort settings remain active only during the current BOM processing session. If you go back to the BOM at a later date, you have to reset the sort.

To define sort settings, choose *Edit* → *Sort*.

You can sort items according to the following criteria:

- *Item number*
In the standard R/3 System, items are sorted in ascending order of item number.
- *Material number*
Items are sorted in ascending order of material number.
- *Sort string*
The items are sorted in ascending order according to the sort string.

Sorting dynamically

If you want to combine sort criteria so that you define an even more precise sort sequence, choose *Sort* → *Dynamic...*

You see a dialog box in which you can select the following five sort criteria:

- *Item number*
- *Item category*
- *Sort string*
- *Description*
- *Object*

In the *Sort* field, define a priority for these sort criteria (a numeric value). For example, you can sort according to *Item category* first, and then according to *Sort string*. In this case, you enter the value **1** in the *Item category* field and the value **2** in the *Sort* field.

You can also use the *Descending* field to define whether the items are sorted in descending order.

If you select *Object* as a sort criteria, you need to define a sort sequence for all objects with an SAP master record in the *Object sort* field. You can also use the *Descending* field to define whether the items are sorted in descending order.



If you want to sort according to object, for example, documents and materials, you define the priority of objects within the sort sequence.

Sorting Items

If you want to see the documents first in the item overview, followed by the materials, enter the value **1** in the *Prio* field for documents and the value **2** in the *Prio* field for materials.

Displaying Header Data



Displaying Header Data

The header data is maintained on a series of tab pages:

You can display BOM header data from any item overview or item detail screen.



If the BOM header has been changed historically (with a change number) within the validity period you enter, the system displays the header overview first. Select the headers whose data you want to display, then choose the function you require again. Then reselect the desired function.

By clicking on  and  you can control the processing sequence of the selected headers.

If you want to display the header data, click .



You can display some header information (for example, technical type, BOM group, base quantity, required quantity) without leaving the item overview. Click  *Header*. You see a dialog box with the most important header information. To close the dialog box, choose *Close*.

See also:

[BOM header \[Page 48\]](#)

Displaying the Validity Data on the Initial Screen

You can display the validity data on the initial screen from any item overview without having to leave the item overview. You see the information in a dialog box.

To display the validity data:

1. Select the *Initial screen* button on the item overview.

You see the *Validity Initial Screen* dialog box, which contains the following data:



- *Change number*
- *Valid-from date*
- *Valid-to date*
- *Revision level*

2. To return to the item overview, choose *Close*.

Displaying Long Texts

Displaying Long Texts

If a long text exists for a BOM or BOM group, alternative or item, the system displays  next to the corresponding short text in the display mode.

Long text for	Display procedure	What you ought to know
Bill of material	<ol style="list-style-type: none"> 1. Select the <i>Quantity/Long text</i> tab page from the header detail screen. 2. Click  next to the <i>BOM text</i> field. 	This text is valid for the entire BOM group.
Alternative	<ol style="list-style-type: none"> 1. Select the <i>Quantity/Long text</i> tab page from the header detail screen. 2. Click  next to the <i>AltText</i> field. 	This text is valid for the individual alternative of a multiple BOM or the variant of a variant BOM.
Item	<ol style="list-style-type: none"> 1. Select the <i>Status/Long text</i> tab page from the item detail screen. 2. Click  next to the <i>Item text</i> field. 	



The  icon is only displayed if a long text exists.

Displaying an Assembly

You can use *Display material BOM* to display all items on the first explosion level of a bill of material. Items that are assemblies have the *Indicator: assembly* on the item overview.

You can display the BOM of an assembly from any item overview or from an item detail screen.

How to display the bill of material of a BOM item:

- If you are on an item overview, select the item whose bill of material you want to display.
- Choose *Extras* → *Display BOM*.

You see the *Material Item Overview* for the selected item, from which you can use all active display functions.

Other Display Functions

Other Display Functions

The following display functions for bills of material are also available:

[Displaying Discontinuation Data \[Page 275\]](#)

[Displaying Allocations to Operations \[Page 276\]](#)

[Displaying Classification Data \[Page 277\]](#)

[Displaying Revision Levels \[Page 278\]](#)

Displaying Discontinuation Data

If certain requirements are met, you can maintain discontinuation data for material components. On the *General data* item detail screen, you can maintain discontinuation data by choosing *Discontinuation*.

See also:

[Discontinuation \[Page 171\]](#)

In addition, you can display or maintain this data for a selected item from any item overview and any item detail screen using a special function call. You display or maintain the discontinuation data in a dialog box without having to leave the current processing screen.

How to maintain the discontinuation data:

1. If you are on an item overview, select the required material component.

If you are on an item detail screen, start with step 2 below.

2. Choose *Extras* → *Discontinuation data*.

You see the *Discontinuation Data* dialog box, which contains the following data:

- Identifying item data (for example, *Item number*, *Material*, *Item category*)
- *Discontinuation indicator* (from the material master)
- *Discontinuation group*
- *Follow-up group*

If you are in change mode, you can maintain either the discontinuation group or the follow-up group.

Confirm your entries.

3. To return to the item overview, choose *Back*.

Displaying Allocations to Operations

Displaying Allocations to Operations

If a routing exists for the selected material in the plant, you can go to the routing without leaving your BOM processing function.

A routing contains all the important information for manufacturing a product. It contains a sequence of operations and defines at which work centers production takes place.

From the BOM display function, you can display the operations of the routing and any existing allocations to material components. This function is active on all item overviews. Operation allocation is only supported for material components. If you try to execute this function for other object types, you see an error message. The allocation display function is also active on all detail screens for material components.

How to display allocations to a routing (operation):

1. On the item overview, select the components for which you want to see the allocations to a routing (operations).
2. Choose *Extras* → *Operation allocation*.
 - If there is no valid routing for the material, you see the following error message:
No valid routing exists
 - If there are several routings, you see a dialog box in which you select a routing group.
 - If one routing exists for the BOM, you see the *Operation overview*.
3. On the *Operation overview* you see the following information:
 - The header of the list contains data which identifies the BOM, the item, and the routing.
 - The *Operations* dataset lists all operations in this BOM whose sequence defines the production flow.

The work centers where processing is to take place are defined in the *WorkCntr* field with a description. The *CtrK* (*control key*) shows you how an operation is to be handled in operative applications (for example, in production orders, and capacity planning).
 - If the item you selected is allocated to an operation, this operation has an indicator next to the operation description.

If you selected several items on the item overview, you can use *Next item* and *Previous item* to display the operation (allocation) for the next or previous item.
4. You can use all active routing functions, such as:
 - Display cutting measurements or administrative data for the material components
 - Display the sequence overview
5. To return to the item overview in the BOM, choose *Back*.

Displaying Classification Data

You can maintain classification data for material items. You can display classification data in the following processing situations:

- If you are on an item overview screen (for example, *Material Item Overview*), select the material item you require, then choose *Extras* → *Classification*.
- Once you have maintained classification data for an item, you see the *Classification* pushbutton in the *BOM item* dataset of the *Item: General Data* screen. Choose *Classification*.

You see the *Classification* screen. On this screen, you can use all active display functions, for example, display characteristic values or class data.

Displaying Revision Levels

Displaying Revision Levels

If you make changes with reference to a change number, you can assign revision levels to specific processing stages.

You can display the revision levels of the header material in any processing situation.

How to display the revision levels of the header material of a BOM:

- Choose *Extras* → *Disp. revision level*.
You see the *Display Material Revision Level* dialog box, which lists all revision levels that have been assigned to the material of the BOM header.
- The first line contains the material of the BOM header.
In the following lines, you see all the revision levels that have been assigned for changes with reference to a change number:
 - *Revision level*
 - *Valid from*
 - *Change number and description*
- To return to the BOM processing function, choose *Continue*.

Working with Configurable BOMs

Purpose

You work with configurable BOMs if you manufacture a product with many variants. You produce the product especially for your customers, who specify how the product should look. In doing this, you use variant configuration.

Process Flow

1. You create a super BOM

Apart from the components that are relevant to all variants, this bill of material also contains selectable components. You maintain the bill of material for a configurable material as you would a normal material BOM.

2. You define in, for instance, object dependencies, the conditions according to which the selectable components should be selected during configuration.

You can find further information under [BOM of a Configurable Material \[Ext.\]](#).

3. You perform configuration, for instance, when entering a sales order.

The system selects the desired and suitable components from those that are selectable.

For more information, see the R/3 Library, under [Variant Configuration \[Ext.\]](#).

Creating a Variant BOM

Creating a Variant BOM

You can describe products that are built in a similar way by using a variant BOM. To create a variant BOM, you extend an existing material BOM by creating a variant.

See also:

[When do I Create a Variant BOM? \[Page 38\]](#)

[Before You Create a Variant BOM \[Page 281\]](#)

[Steps for Creating a Variant BOM \[Page 283\]](#)

Before You Create Your BOM

Before you create a variant BOM, please note the following:

- The material for which you want to create a variant of an existing BOM must not have a BOM.
- The BOM of the material that you want to use to create a variant cannot be a multiple BOM.
- The material whose BOM (variant BOM) you want to copy must have a BOM with the same usage as the one you selected for your new variant.
- Does the BOM that you want to use to create a variant have a history requirement?
If so, which change number do you use? If you want to make the change with reference to an engineering change request (ECR), the ECR must first be converted to an engineering change order (ECO).
- The base units of measure of the variant materials must be the same, because the BOMs base unit of measure must be the same as the base unit of measure in the material master record.
- All the variants of one variant BOM form a BOM group. Within the BOM group, each item has a unique item ID. You can enter the same item ID for logically-related items, such as different versions of an item.

Variant BOM: Example

The racing bicycle HRR01 is produced in the following color options:

- Blue frame
- Red frame
- Black frame

This means that there are 3 similar products (variants) with different colored frames.

There are 3 different variants of assembly *Preassembled frame and forks*:

FRAME01 With component FR01 (*Blue frame*)

FRAME02 With component FR02 (*Red frame*)

FRAME03 With component FR03 (*Black frame*)

The following graphic shows the 3 variants in the variant BOM for this bicycle.

Before You Create Your BOM

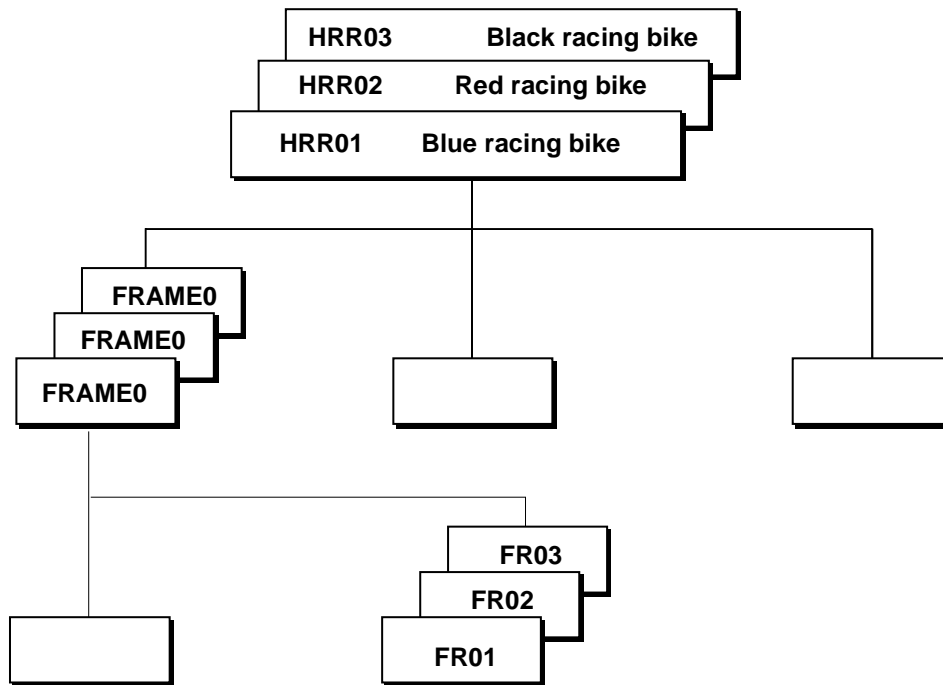

Steps for Creating a Variant BOM

When you create a variant BOM, you carry out the following steps:

1. [Maintaining the Initial Screen for Creating a Variant BOM \[Page 284\]](#)
2. [Selecting a Variant BOM to Copy \[Page 286\]](#)
3. [Copying Data from an Existing Variant \[Page 287\]](#)
4. [Maintaining and Saving Variant BOM Data \[Page 288\]](#)

Maintaining the Initial Screen for Creating a Variant BOM

Maintaining the Initial Screen for Creating a Variant BOM

How to maintain the initial screen for creating a variant BOM:

1. From the bills of material menu, choose *Material BOM* → *Create*.

You see the *Create material BOM* initial screen.

2. Enter the data for the variant BOM you want to create.



The material for which you want to create a variant of an existing BOM cannot have a BOM with the same usage in the selected plant.

- In the *Material* field, enter the material for which you want to create a variant.
- In the *Plant* field, enter the plant in which you want the variant to be valid.

The BOM that you want to use to create a variant must exist in this plant.



You can extend the area of validity of the BOM later on by using the *Create plant allocation* function.

- Enter the *Usage*.

If a default parameter is defined for the *Usage* field in your user master, you see this value. Otherwise you see the usage that was last entered in this field.

When you select a usage, please note that the usage determines which item statuses you can set. This means that you can only maintain certain indicators (for example, relevant to production, relevant to costing) at item level.

The material that you want to use to create a new variant in the selected plant must already have a BOM with the usage that you enter here.

- Do not make an entry in the *Alternative* field, for a variant BOM.

In a variant BOM, the alternative is not relevant to the user. The alternative is only required internally for storing the variant BOM. For this reason, if you do make an entry in the *Alternative* field, the system ignores your entry.

3. Enter the validity data for the variant BOM.

See also:

[Maintaining the Create Material BOM Initial Screen \[Page 219\]](#)



If you create the variant with reference to a change number, the entire BOM group (this includes all variants of the variant BOM) has a history requirement.

This means that you can only change or extend the BOM if you enter a valid change number.

4. If you want to check the data you enter, choose *Check entries*.

Maintaining the Initial Screen for Creating a Variant BOM

Do **not** confirm your entries by choosing **ENTER**, because this creates a simple BOM.

Selecting a Variant BOM to Copy

Selecting a Variant BOM to Copy

How to select a variant BOM to copy:

1. If the data you entered on the initial screen is correct, choose *Create variant of*.
You see the *Create variant of* dialog box.
2. In the *Material* field, enter the material whose BOM you want to use to create a variant.
3. Confirm your entries.

The system makes a series of checks, for example:

- The system checks whether a BOM already exists for this material. The system determines the values for the plant and usage from the data you entered for the new variant on the initial screen.
- If no items are valid on the valid-from date you entered on the initial screen, you see the following warning message:

No items are valid on <valid-from date>

Confirm this message. You see the *Quantities/long text* header detail screen.

If your data is correct, you see the *Copy from* screen. This screen shows the items of the BOM you are copying.



Copying Data from an Existing Variant

On the item overview of the template, you can check the items and copy them to the new variant, if required.

How to copy items from the source BOM (variant BOM):

1. Check the items you want to copy.

Select  to display all data for the item.

If you selected several items on the item overview, you can influence the order in which you process the selected items. To see the data for the next or previous item, choose  and .

By clicking on  you go back to the item overview of the template.

2. Select the items you want to copy.
3. Click  to transfer.

The system copies the header data and the items you selected from the source BOM to the new BOM you are creating.



The *Copy* function always copies the BOM header of the source BOM. If the BOM that you are using to create a variant does not contain any valid items, or if you do not select any items, you see a warning message. You see a dialog box, in which you can decide whether to copy the header only.

Maintaining and Saving Variant BOM Data

Maintaining and Saving Variant BOM Data

When you execute the *Copy* function, the system copies the data you selected from the existing variant. You see the item overview of the new variant, with all the objects you selected.

How to change and complete the copied header and item data:



- Add additional items

Enter a new item in an empty line of the item overview.

- Change or enhance header data

Click .

- Change or enhance item data

From the item overview, select the items that you want to change and click . If you have selected several items, you can flip between them using the  and  buttons.

Save your BOM.

Options for Changing Variant BOMs

There are two ways of changing a variant BOM.

- To change an item that is used in **one** variant BOM (variant part), choose *Material BOM* → *Change*.
See [Changing one Variant BOM \[Page 290\]](#).
- To change an item that is used in all variants in the BOM group (non-variable part), choose *BOM group* → *Change*.
See [Hints on Changing a BOM Group \[Page 427\]](#).

Changing one Variant BOM

Changing one Variant BOM

To change **one** variant BOM in a BOM group, choose *Material BOM* → *Change*.



Choose this function if you want to make a specific change to one variant, such as changing a variant part.

If you want to change an item that is used with the same data in all variants of the BOM group (non-variable part), choose *BOM group* → *Change*.

To change a variant BOM:

1. Choose *Material BOM* → *Change*.
You see the *Change material BOM* initial screen.
2. Enter your data on the initial screen.
 - The *Alternative* field is not relevant to variant BOMs, so do not make an entry in this field. If the system displays a message about an entry in this field, confirm the message.
 - Enter a *Valid-from date* or *Change number*.

If you change a variant BOM with reference to a change number, you may see an error message telling you to check the object management records.

See also

[Changing a Variant BOM – Special Points \[Page 341\]](#)

3. Confirm your entries.
You see the material item overview. From this screen, you can use all the general functions for changing BOMs.
You can edit a long text for your specific variant from any header detail screen. This text describes only **one** variant in the BOM group. You see this text in the *AltText* field. (For a multiple BOM, you see the text for an alternative in this field.)
4. Save your changes.

Options for Displaying Variant BOMs

There are two ways of displaying a variant BOM.

- To display an item that is used in **one** variant BOM (variant part), choose *Material BOM* → *Display*.
See [Displaying One Variant BOM \[Page 292\]](#).
- To display an item that is used in all variants in the BOM group (non-variable part), choose *BOM group* → *Display*.
See [Displaying a BOM Group \[Page 430\]](#).

Displaying One Variant BOM

Displaying One Variant BOM

You can choose *Material BOM* → *Display* to display the item overview of a specific variant in a BOM group. You see the *General Item Overview* screen with all valid items.

How to display one variant BOM:

1. From the bills of material menu, choose *Material BOM* → *Display*.

You see the *Display material BOM* screen.

2. Enter your data on the initial screen.

Enter a validity period, and the required quantity for which you want to see the *Material item overview* with all valid items.



When you are working with a variant BOM, the alternative is not relevant. For this reason, you do not need to make an entry in the *Alternative* field. The system ignores any entry you do make. If the system displays a message informing you that you have entered an alternative, confirm the message.

3. Confirm your entries.

You see the *Material Item Overview*. From this screen, you can use all the general display functions for BOMs.

From each header detail screen, you can display a specific long text for the variant. This is only used to describe the individual variant within the BOM group. This text is displayed in the *AltText* field. (In a multiple BOM, this field refers to an alternative.)

Creating a Multiple BOM

You use a multiple BOM to describe the alternative combinations of components for one material that exist due to different production processes. To do this, you extend an existing material BOM by creating an alternative.

See also:

[When do I Create a Multiple BOM? \[Page 40\]](#)

[Before You Create a Multiple BOM \[Page 294\]](#)

[Steps to Creating a Multiple BOM \[Page 296\]](#)

Before You Create Your BOM

Before You Create Your BOM

Before you create a multiple BOM, please note:

- The material BOM for which you want to create an alternative cannot be a variant BOM.
- Does the BOM for which you want to create an alternative have a history requirement?
 - If so, which change number do you use?
 - If you want to make the change with reference to an engineering change request (ECR), the ECR must first be converted to an engineering change order (ECO).
- All the alternatives of one multiple BOM form a BOM group. Within the BOM group, each item has a unique item ID. You can enter the same item ID for logically-related items, such as different versions of an item.

Multiple BOM: Example

One model of the racing bicycle HRR01 is produced in **blue**. The assembly BLUE_FRAME contains component PAINT01 (blue paint).

This component is also an assembly, and contains the following material components:

- Pigment
- Solvent
- Water

Depending on the lot size, the quantities of these components change. There are 3 alternative BOMs (alternatives) for assembly PAINT01:

Alternative 1	Lot size	1-100
Alternative 2	Lot size	101-200
Alternative 3	Lot size	201-1,000

The following graphic shows the 3 alternatives of multiple BOM PAINT01.

Before You Create Your BOM

COLOR0	Alternative 1	Lot size	1 - 100
	Alternative 2	Lot size	101 - 200
COLOR	Alternative 3	Lot size	201 - 1000

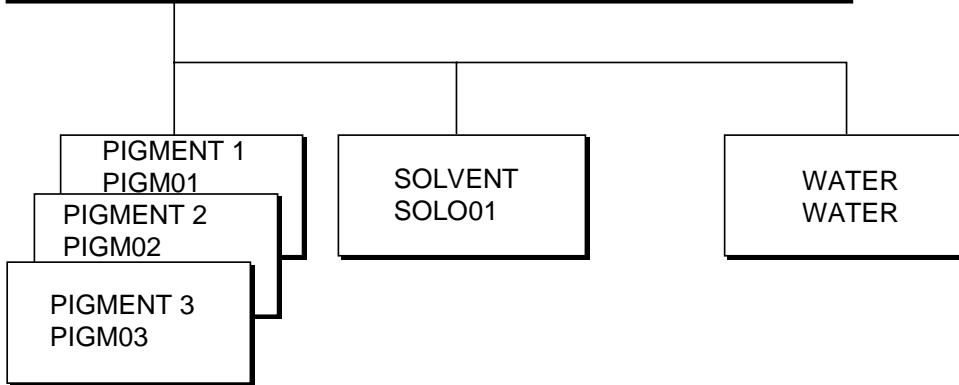

Steps to Creating a Multiple BOM

Steps to Creating a Multiple BOM

When you create a multiple BOM, you carry out the following activities:

1. [Initial Screen for Creating a Multiple BOM \[Page 297\]](#)
2. [Copying an Existing BOM \[Page 299\]](#)
3. [Copying Items from the Existing BOM \[Page 300\]](#)
4. [Maintaining and Saving Multiple BOM Data \[Page 301\]](#)

Initial Screen for Creating a Multiple BOM

How to maintain the initial screen for creating a multiple BOM:

1. From the bills of material menu, choose *Material BOM* → *Create*.

You see the *Create material BOM* initial screen.

2. In the *Material* field, enter the material for which you want to create an alternative.



You can only add an alternative to a simple material BOM (technical type = " ") or a multiple BOM (technical type = M).

3. In the *Plant* field, enter the plant in which you want the multiple BOM to be valid.

Please note that the BOM for which you want to create an alternative must exist in the plant you enter here.

4. Enter the *Usage*.

If a parameter for the *Usage* field is defined as a default value in your user master record, you see this value. Otherwise you see the last usage entered in this field.



When you select the *Usage*, please note that the usage defines which item statuses you can set. This means that you can only maintain specific indicators (for example, relevant to production, relevant to costing) at item level.

The material for which you want to create an alternative must already have a BOM in the selected plant with the *Usage* you enter here.

5. In the *Alternative* field, you identify the BOM within the BOM group.
 - If you want to assign a name to the alternative, enter an alphanumeric character string in the *Alternative* field.
 - If you want the system to automatically assign a name to the alternative, do not make an entry in this field. The system automatically determines the next available alternative (numeric sequence).
6. Enter your validity data. See [Maintaining the Create Material BOM Initial Screen \[Page 219\]](#).



If you create the alternative with reference to a change number, the BOM group (all alternatives of a multiple BOM) has a history requirement for all further changes.

This means that you can only change or extend the BOM if you enter a valid change number.

- If you enter a change number, the system determines the valid-from date of the BOM from the *Valid from* field in the change master record.
- If you want to change the BOM without reference to a change number, do not make an entry in the *Change number* field.

Initial Screen for Creating a Multiple BOM

7. If you want to check your data, choose *Check entries*.
If your data is correct, you can copy data from an existing BOM.

Copying an Existing BOM

The differences between alternative BOMs for a material are usually only very small (for example, the component quantities are different). For this reason, you can copy an existing alternative.

How to copy an existing BOM:

1. If your data on the initial screen is correct, choose *Copy from*.

You see the following warning message:

Alternative <number> added to BOM (multiple BOM)

Confirm this message. If the BOM for which you want to create an alternative has a history requirement, you see a message. In this case, you can only create an alternative if you enter a valid change number.

You see the *Copy from* dialog box.

2. This dialog box contains the header data of the BOM for which you want to create an additional alternative (*Material, Plant, Usage*).

The *Alternative* field is available for entry.

You have the following options:

- In the *Alternative* field, enter the alternative from which you want to copy BOM data. Confirm your entry.
- If the BOM you are copying is a multiple BOM and you do not make an entry in the *Alternative* field, you see the *Alternative overview*.

Select an alternative from the alternative overview. Choose *Copy from*.

You see the item overview of the BOM you are copying from.



If there are no valid items on the valid-from date you entered on the initial screen, you see the following warning message:

No items are valid on <valid-from date>

If you confirm this warning message, you see the *Quantities/long text* header detail screen of the BOM that you are copying.

Copying Items from the Existing BOM

Copying Items from the Existing BOM



On the item overview of the template, you can check the items and copy them to the new alternatives to be created, if required.

How to copy items from the existing BOM (alternative):

1. Check the items you want to copy.

Click .

If you selected several items on the item overview, you can control the sequence in which you process the items.

To see the data for the next or previous item, choose  and .

By clicking on  you go back to the item overview of the template.

2. Select the items you want to copy.

3. Click  to transfer.

The system copies the header data and the items you selected from the source BOM to the new BOM you are creating.



The *Copy* function always copies the BOM header of the source BOM. If the BOM that you are using to create a variant does not contain any valid items, or if you do not select any items, you see a warning message. You see a dialog box, in which you can decide whether to copy the header only.

Maintaining and Saving Multiple BOM Data

When you execute the *Copy* function, the system copies the data you selected from the existing alternative. You see the *Material* item overview of the new alternative, containing all the objects you selected.

How to edit and complete copied header and item data:

- If you want to add more material items, choose *1-line new items*.

Enter your items.

- If you want to add to the header data, choose *Goto → Header → Full*.
- If you want to edit specific item data and you know which detail screen this data is on, select the items you require (column S).

Choose *Goto → Item → <item detail screen>* (for example, *Status/long text*). Enter your data.

- If you want to edit all detail screens for an item, select the items you want to process (column S).

Choose *Goto → Item → Full*.

Confirm your data. You see the item detail screen for the next item you selected.

When you have finished maintaining your data, save your BOM. You see the following message:

BOM for material <material number> created

Options for Changing a Multiple BOM

Options for Changing a Multiple BOM

There are two ways of changing a multiple BOM.

- If you want to change an item that is used in **one** alternative of a multiple BOM (variant part), choose *Material BOM* → *Change*.

See [Changing one Alternative in a Multiple BOM \[Page 303\]](#).

- If you want to change an item that is used in all alternatives of a BOM group (non-variable part), choose *BOM group* → *Change*.

See [Hints on Changing a BOM Group \[Page 427\]](#).

Changing one Alternative in a Multiple BOM

To change one alternative in a BOM group, choose *Material BOM* → *Change*.



Use this function if you want to make a change to one alternative, such as changing a variant part.

If you want to change an item that is used with the same data in all alternatives in the BOM group (non-variable part), choose *BOM group* → *Change*.

To change one alternative in a multiple BOM:

1. Choose *Material BOM* → *Change*.

You see the *Change material BOM* initial screen.

2. Enter the data that identifies the alternative you want on the initial screen.
3. Enter a valid-from date or a change number.

If you do not enter an alternative, first you see the alternative overview. Select the alternative you want to change.

4. Confirm your entries.

You see the material item overview. From this screen, you can use all general functions for changing a BOM.

You can edit a long text for your alternative from any header detail screen. This text describes only this alternative in the BOM group. You see this text in the *AltText* field.

5. Save your changes.

Options for Displaying a Multiple BOM

Options for Displaying a Multiple BOM

There are two ways of displaying a multiple BOM.

- If you want to display an item overview for **one** alternative, choose *Material BOM* → *Display*.
See [Displaying one Alternative in a Multiple BOM \[Page 305\]](#).
- If you want to display a summarized BOM with all items in **all** alternatives of the BOM group, choose *BOM group* → *Display*. The list of alternatives shows you which items are used in which alternatives.
See [Displaying a BOM Group \[Page 430\]](#).

Displaying one Alternative in a Multiple BOM

You can use this function to display a specific alternative from a multiple BOM for a specific validity period.

How to display a variant BOM:

1. From the bills of material menu, choose *Material BOM* → *Display*.

You see the *Display material BOM* screen.

2. Enter your data on the initial screen.

Please note the following information on the *Alternative* field:

- If you want to display a specific alternative and know the name of the alternative, enter the alternative. The system then goes directly to the *Material item overview* of this alternative.
- If you do not know the alternative, or if you want to select an alternative from the alternative overview, do not make an entry in the *Alternative* field.

Confirm your entries. You see the alternative overview, listing all valid alternatives that have the usage you entered.

Displaying an Alternative from the Alternative Overview

Displaying an Alternative from the Alternative Overview

Use

The alternative overview lists all BOMs that exist for the multiple BOM (*Material/Plant/Usage*) you entered.

Procedure



How to display an alternative from the alternative overview:

1. Select the alternatives for which you want to display data.
 - If you want to display the item overview of **one** alternative, select the line containing the alternative you require. By double clicking you goto the item overview.
 - If you want to display the item overview of several alternatives, select the alternatives you require and click the  *Item* button.

By clicking on  and  you can flip between the selected alternatives.

2. If necessary, display the item data for the selected alternatives:

Select the  button on the item overview.

By clicking on  and  you can flip between the selected items of the individual alternatives.

3. If necessary, display the header data for the selected alternatives:

Click .

By clicking on  and  you can flip between the selected alternatives.



If you select a header detail screen from the initial screen, and the BOM header has been changed with Engineering Change Management within the validity period you entered, you see a header overview first.

4. If necessary display the long text for the selected alternatives:

Select the desired alternative and click .

Then click  *AltLtext*.

BOM Changes in the SAP R/3 System

In the R/3 System, you can change bills of material either with or without saving a history.

- **Change without history**

A change made during the development phase of a product that does not need to be document.

The state of the bill of material before the change is **not** stored. You can only process the data you last saved.

- **Change with history**

A change that may require further activities within the company and which must be verified (for example, Change BOM → Change routing → Change inspection plan).

Engineering change management in the R/3 System enables you to document all changes.

- The header and item records are duplicated.
- Changes to sub-items are not saved historically, even if you make these changes with reference to a change number.

Changes Without History

Changes Without History

When you change a BOM **without** reference to a change number, the change objects (for example, BOM header or item) are changed directly in the BOM. The system does not duplicate header or item records. As a result, you can no longer display the status before the change. However, changes are logged in change documents. These change documents contain both the old and the new field values.

Example of a change without history:

Item 0010 has been entered in a BOM with the valid-from date **t0**.

You change item 0010 for valid-from date **d1** by replacing component **A** with component **B**. You make this change **without** reference to a change number.

- The system does **not** store the status of the BOM before the change (item 0010 with component A).
The valid-from date of item 0010 is the valid-from date of component B.
- Even after the change, the changed item has only **one** validity period (d0 – 12/31/9999).



To change a BOM, either with or without history, always choose *Material BOM* → *Change*.

The only difference is that you do not enter a change number if you change without history.

On the initial screen, in the *Valid from* field, enter a date from within the validity period of the BOM. The change is automatically valid for the entire period (beginning with the creation date).



The system automatically generates change documents for changes without reference to a change number.

See also:

[Displaying Change Documents \[Page 421\]](#)

History Requirement for BOMs

Use

You use the history requirement to determine that BOMs can only be processed with a change number.

Prerequisites

In Customizing for *Production*, you define the history requirement settings under:

- *Bill of Material* → *Control Data* → *Define modification parameters*
- *Bill of Material* → *General Data* → *Define history requirement for BOMs*

Features

History Requirement for New BOMs

In the modification parameters, you define when a BOM that you are **creating** is subject to history requirement.

- *BOM* → *Create*
All BOMs must be created with a change number. This setting overrides the settings for a BOM group.
- Creating a BOM in a *BOM group*
 - Create variant (variant BOM)
 - Create alternative (multiple BOM)

All new variants and alternatives must be created with a change number. In the modification parameters in Customizing, you can define when a BOM group is subject to history requirement.

History Requirement for New Variants and Alternatives

In the modification parameters in Customizing, you can define when new BOMs in a BOM group (variant BOM or multiple BOM) are subject to history requirement.

History Requirement for BOM Maintenance

In Customizing, you can define under *General Data* that all BOMs with at least a certain **status** are subject to history requirement. You define this setting for each BOM usage.

Activities

If you want to create or process a BOM in a situation where the BOM is subject to history requirement, you must enter a change number.

If you have special authorization, you can change a BOM that is subject to history requirement without entering a change number ([Authorization object C_STUE_NOH \[Page 23\]](#)).

Engineering Change Management for BOM Changes

Engineering Change Management for BOM Changes

You use engineering change management to change BOMs **with** history. You make changes with history by referring to a change master record.

A change with history has the following distinguishing features:

- In the standard R/3 System, the change comes into effect on a specific date.
If the change master record has an effectivity type, the change comes into effect when certain parameters apply (for example, range of serial numbers).
- The changed object is stored twice: in its **pre-change** state and in its **post-change** state. The pre-change state of the object ends on the valid-to date. The post-change state of the object starts on the valid-from date.
- Changes are documented in a change master.
- You can use an engineering change request (ECR) to control the change process. An ECR is converted to an engineering change order (ECO).
- You can assign a revision level to certain change statuses (versions) of a material or document.
- If your change is subject to special security requirements, you can use digital signatures to make additional authorization checks.

Transaction Processing Using an ECR

An engineering change request (ECR) is a change master record with a change type. The change type represents general business transactions in logistics that need to be carried out to effect the change.

In Customizing for *Logistics General*, you can define change types, which control the process flow of changes, by choosing *Engineering Change Management* → *Define change types for change master records* or *Engineering Change Management* → *Define change types for objects*.

You define these change transactions in the form of a status network.

- The *System status*, which controls the process flow of the change master record and the change objects, is already defined in the standard R/3 System, and is assigned automatically to each change type.
- You can define an approval procedure to determine which users are authorized to perform the individual steps in the process.
- In Customizing for *Logistics General*, you can also define a *User status*, which divides up and checks the process flow in more detail, by choosing *Engineering Change Management* → *Define status profile*.
- In the Workflow Workbench, you can define a *Workflow task*, which is triggered as soon as a specific status is reached.

For each processing status of the change master record, the system checks which change transaction is defined for both the change master record and the change objects (for example, BOM or document).



The change objects, such as BOMs, cannot be processed with an ECR until it has been converted to an engineering change order (ECO).

For more information on ECRs, see the R/3 Library, under *LO Engineering Change Management*.

Change Master Records

Change Master Records

[Change Master Records \[Ext.\]](#) contain data that both defines and controls a change. Other data also provides you with information on changes made to the change master record.

This data is maintained on a number of screens. The main data is included on the following screens:

- [Initial Screen \[Ext.\]](#)
On this screen, you enter the change number to identify the change master record.
- [Change Header \[Ext.\]](#)
The change header includes fields that define the change (such as the valid-from date), fields that describe the change (such as the reason for change), and some administrative data.
- [Object Types \[Ext.\]](#)
Object types let you determine which objects can be changed using the change master record. If you want to process BOMs with the change master record, you must specify various object type indicators for object type *Bill of material*.
Object sub-types let you determine more precisely how you want to process different types of BOM (such as material BOMs and document structures).
- [Alternative Dates \[Ext.\]](#)
The general valid-from date in the change header can be replaced by a different valid-from date for a specific change made to an object. To do this, enter an alternative date and then assign one or more change objects to it.
- [Object management records \[Ext.\]](#) (*general object overview and specific object overviews*)
The object management record allows you to control changes to a specific object.
- [Detail Data \[Ext.\]](#) of an **object management record** (for selected change objects)
This screen allows you to define the exact change to be made to a specific object. You can also use the selected change number to lock the object to prevent changes.
- [Status Management \[Ext.\]](#) (if a change type is assigned)
If you make a change with an engineering change request (change master record with a change type), you can use the system status and, if necessary, the user status to determine how the change master record is processed.
- [Effectivity Data \[Ext.\]](#) for **parameter effectivity**
If you use an effectivity type (such as effectivity by serial number) in the change master record to define the effectivity of a change, enter the values for the effectivity type (for example, a range of serial numbers).

Object Management Records and BOM List

For some object types (for example, BOMs, documents), you can use object management records in the change master record to control changes to individual objects. An object management record documents changes to an individual object. You can also set an object-specific valid-from date and status network.

BOMs that belong together in a BOM group, are stored under one internal BOM number. Only one BOM appears in the object overview.

This is the case if, for example:

- A material BOM is extended by one variant
- A material BOM is allocated to an additional plant

In the object overview of the change master record, you see the **first** BOM from the BOM group that was entered as an object for the change number.

Starting from the *General object overview* or a special overview for BOMs (for example, the *Material BOMs overview*), you can display all the BOMs in a BOM group by choosing *BOM list*, as shown in the following graphic.

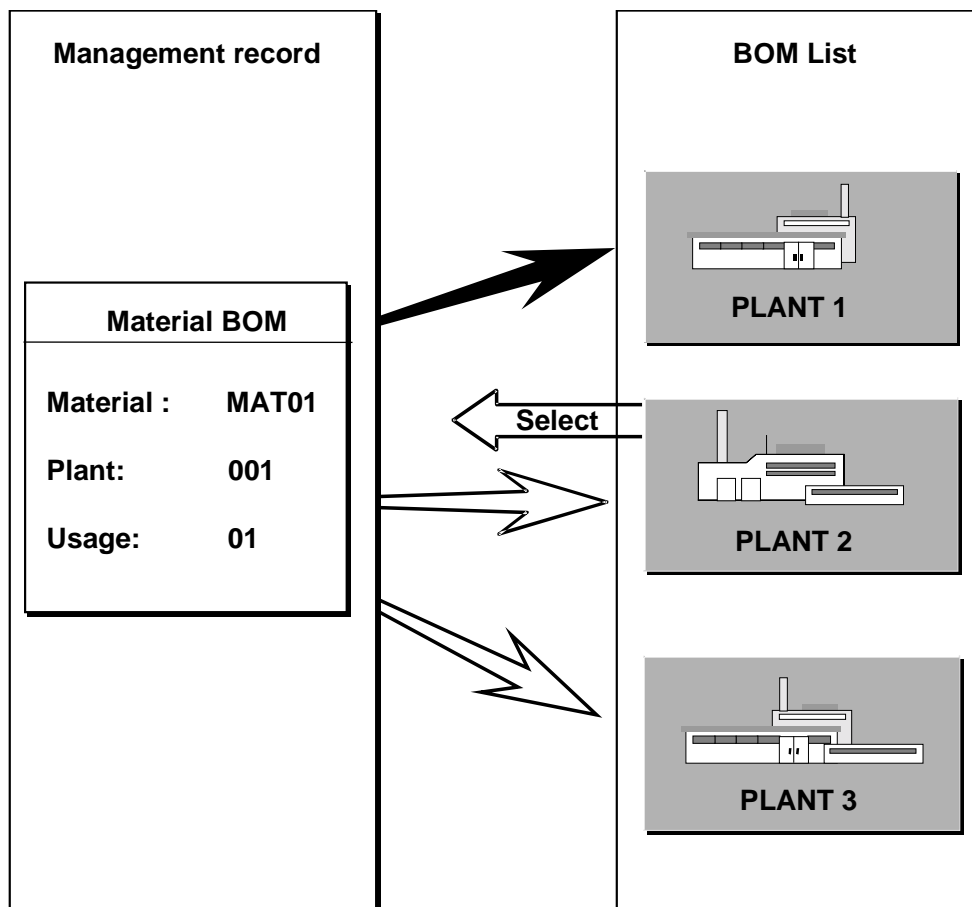

Object Management Records and BOM List

The BOM list contains all the BOMs in the BOM group. The system sets the following indicators as appropriate:

- *BOM exists* A BOM exists for the material displayed.
- *ObjM.ex* An object management record exists for the material displayed.



Usually, the *Object management record is generated (MgtRec)* indicator is set for one BOM. This BOM then represents the BOM group in the object overview.

You can select another BOM from the list. You may want to do this, for example, if the BOM for which the object management was created has been deleted, as shown in the following graphic.

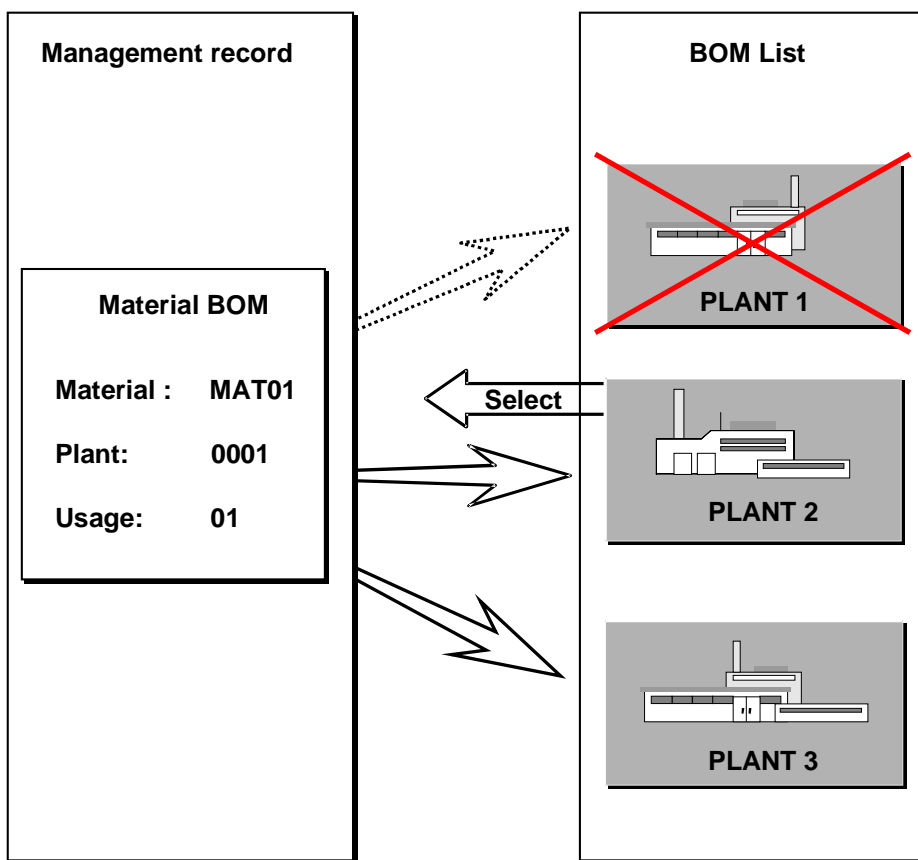

Revision Levels

If you make changes to a material with reference to a change number, you can assign a revision level to specific change statuses. This allows you to process the objects later with reference to either a change number or a revision level.



In Customizing for Logistics General, you can activate revision levels for your company by choosing *Engineering Change Management* → *Control data*. You can also define the order in which revision levels are assigned to materials by choosing *Engineering Change Management* → *Revision levels* → *Define revision levels for materials*.

Before you can assign a revision level to a material for a specific change number, the following requirements must be met in the change master record:

- The indicators *Object type active for change number* and *Management record required for each object* must be set for the object type *Material*.
- An object management record must exist for the selected object.
You can either enter this manually or have it generated automatically by the system. To have it generated automatically, you must set the indicator *Object management record generated* in the change master record.
- If you want to assign the revision level with indicator reference to an engineering change request (a change master record with a defined change type), the change request must first be approved and converted to an engineering change order. To do this, you set the appropriate system status.
- If you defined when you configured your system that the system is to check protected time periods, the valid-from date of the selected change master cannot be in this period.



The indicator for the processing status of a material is unique. This means that you can only assign one revision level to the material (BOM header material) for a change made with reference to a **specific** change number (for example, CH01).

You can only assign a new revision level for a change made with reference to a different change number.

You can assign a revision level to a material either from engineering change management or directly when processing the material (for example, in the material master record or in the BOM). This section describes how to process a revision level from BOM processing functions.



The table below shows BOM changes for material AA, plant 0001, usage 01. The changes are made with reference to three change numbers. Two changes also have revision levels assigned to them.

Changes to the BOM for material AA

Change number	Valid-from date	Revision level assigned
---------------	-----------------	-------------------------

Revision Levels

AA	01/01/1998	yes (01)
BB	02/01/1998	
CC	03/01/1998	yes (02)

This means that material AA has the following revision levels: 01 and 02.

You can process the material on 01/01/1998 using change number AA or revision level 01.

Before You Change a BOM

Before you change a BOM, you should consider the following questions:

- Does the change need to be documented for future reference?
- Is there a history requirement for the BOM?
- Do you need to create a change master record?
- Is the valid-from date of the change number in a protected time period?
- Which change number do you want to use for the change?

Changing a Material BOM

Changing a Material BOM

This section describes how to change a simple material BOM with history. You change variant BOMs and multiple BOMs in the same way. For additional information on these technical types, see the end of the section.

See also:

[Before You Change a BOM \[Page 317\]](#)

[Steps \[Page 319\]](#)

Steps for Changing a BOM

How to change a material BOM:

1. [Change Material BOM Initial Screen \[Page 320\]](#)
2. [Changing Item Data \[Page 322\]](#)
3. [Changing Items on the Item Overview \[Page 323\]](#)
4. [Changing Item Data on an Item Detail Screen \[Page 325\]](#)

Change Material BOM Initial Screen

Change Material BOM Initial Screen

1. From the bills of material menu, choose *Material BOM* → *Change*.

You see the *Change material BOM* initial screen.

If a default BOM usage is defined in your user master record, you see either this default value or the last BOM usage entered.

2. Enter the data of the BOM you want to change.
 - In the *Material* field, enter the material whose BOM you want to change.
 - In the *Plant* field, enter the plant in which you want to change the BOM.
 - Enter the *Usage* if required.
 - For a simple material BOM or a variant BOM, do not enter an *Alternative*.
3. Enter the effectivity data.
 - If the state of the BOM before the change is to be retained, enter a change number. The system determines the effectivity data from the change master record.

If the valid-from date of the change number is in a protected time period and you see a warning message, confirm the warning and continue to make the change. If you see an error message, you cannot change the BOM with this change number.

If the BOM has already been changed with one or more change numbers, and you want to select one of these, choose *Extras* → *More* → *All chg nos for BOM*.
 - If the processing status of the BOM header material has one or more revision levels assigned to it, and you want to process a specific revision level again, enter the revision level in the *Revision level* field. The possible entries function shows all the revision levels that have been assigned to the selected BOM header material.

The system determines the valid-from date from the change master record.



Once you process one BOM that is part of a BOM group (alternative of a multiple BOM or variant of a variant BOM) with a change number, you must use a change number to process all BOMs in the group.

4. Confirm your entries.



If the material BOM is allocated to several plants, you see a warning message. The changes you make to the BOM are relevant to all plants. For this reason, the system checks whether your user master record contains the field values required for authorization object C_STUE_WRK.

- You see a message telling you which valid-from date was copied from the change master record.
- Confirm this message.
- If this date is in the past or more than one year in the future, you see another message. Confirm this message, as well.

Maintaining Item Data

Maintaining Item Data

In the standard R/3 System you go to the *Material* item overview. If your entries on the initial screen are correct, this overview lists all material components that are valid on the valid-from date.

You can also maintain document data and class data (only for configurable BOMs) on additional tab pages. For each object type, there is a special item overview with the key fields for identifying the objects.



Items whose validity period is inside the validity period of the change number you entered are highlighted and their fields are ready for input. You can only change these valid items with reference to the change number or the revision level you selected.

See also:

[Item Entry and Master Record \[Page 137\]](#)

[Tab Page in the Item Detail Screen \[Page 138\]](#)

Changing Items on the Item Overview

You cannot change the following data on the item overviews for materials, documents, and classes:

- Validity data for an item
- Item category
- Component description
You enter this description in the master record (for example, material master record, document info record, or class).
- Assembly indicator
The system sets this indicator automatically.
- Sub-items indicator
The system sets this indicator automatically.

You can only make certain changes to the following data:

- Item categories without reference to an object
You cannot enter certain data, such as a component number.
- Items with sub-items
You cannot change the component quantity on the item overview.
The system calculates the item quantity from the sum of the sub-item quantities (sub-item overview).
- Document item
The component unit of measure is always PC (piece).

You can change all the other fields that are available for entry on the item overview screen. You can, for example, replace a component or change a quantity.

Change to an Item: Example

The BOM for the **Racing bicycle MRB01** is changed with change number **CH01**. The valid-from date for the change (07/01/1996) comes from the change number.

Item **0010 BRLV** (Brake lever), created on 05/14/1996, is changed as follows:

- Change to component quantity (old value 1 -> new value 2)
- Sub-items entered for the item (there were no sub-items before the change)

If you display the changed BOM over its entire validity period, you see two different item records for item **0010 BRLV** (Brake lever) in the item overview.

Before the change

Validity period	
<i>Valid from:</i>	05/14/1998
<i>Valid to:</i>	07/01/1998

Changing Items on the Item Overview

Component quantity	1 piece
No sub-items exist	

After the change (change number CH01)

Validity period	
<i>Valid from:</i>	07/01/1998
<i>Valid to:</i>	12/31/9999
Component quantity	2 pieces
Sub-items exist	

Changing Item Data on a Detail Screen

How to change item data on a detail screen:

1. Select the items you want to change from the item overview.

If you want to change **all** existing items in one step, click .

2. Click .

The *Change material BOM* initial screen appears. *Item: All data.*



If you want to display the master record of an item, choose *Environment* → *<object type>*.

3. Change the item data on individual tab pages.



If you want to change data on several tab pages note that certain tab pages are only maintained for certain item types. For example that tab page *Variable-size item* is only available for variable-sized items.

Consider the following points for the individual tab pages:

Basic data tab page

- You enter the quantity of variable-size items on a separate screen (*Variable-size item data* detail screen).
- For stock items and non-stock items with a material master record, you can maintain alternative units to the base unit of measure.
In BOMs, only the base unit of measure and the unit of issue are used. See [Item data relevant to material items \[Page 61\]](#).
If you do **not** enter a unit for an item with a material master record, the system enters a unit from the material master record. If a unit of issue is entered on the storage detail screen of the material master, the system copies this unit to the BOM. Otherwise, the system copies the base unit of measure to the BOM.
- For document items, text items, and non-stock items without a material master record, the system enters the default unit of measure PC (piece).
- You cannot maintain scrap data for document items, test items, and intra materials.

Status/Long Text tab page

- For costing relevant items, the *Indicator: Bulk material* is not planned (also if the indicator is planned as an optional entry in the definition of the BOM usage).
- If you process an item for which the possible item statuses support processing of data for plant maintenance, you can only maintain plant maintenance data if the *Item relevant to plant maintenance* status indicator is set.
- If you want to enter a longer item text, you can maintain a long text by choosing *Extras*. In this case, the system copies the first 80 characters of the item text to the long text.

Changing Item Data on a Detail Screen*Variable-sized item* tab page

- This tab page is only available for variable-sized items.
- When you change variable-size item data, the variable-size item quantity must be recalculated. The quantity is not recalculated until you delete the existing quantity.
- The size unit and variable-size item unit are interdependent. You must be able to convert the size unit to the variable-size item unit.

The dimension of a variable-size item unit is the same as the dimension of the result of the variable-size item formula.

If these units are not of the same dimension, you must maintain conversion factors in the material master record.

Purchasing data tab page

- This tab page is only available for non-stock items.
- If you change the G/L account in the *Cost element* field, the system determines the valuation area from the plant you entered on the initial screen. The valuation area can comprise one plant or all the plants in a company code. The G/L account must be valid in the area determined.

Document assignment tab page

- This tab page is only available for material items.

See also: [Document Assignment \[Page 206\]](#)

Creating New Items

You create new items in the item overview. The system automatically proposes existing item numbers.

If not enough empty lines are displayed for the new items, select *New Entries*.

The relevant data for the item categories is displayed on different tab pages for materials, documents and classes (only configurable BOMs).

On this screen, you can perform the following functions:

- [Entering Material Items \[Page 224\]](#)
- [Entering Document Items \[Page 225\]](#)
- [Entering Class Items \[Page 226\]](#)
- Entering [Text Items \[Page 136\]](#)

See also:

[Prerequisites for Item Entry \[Page 222\]](#)

[Identifying BOM Items \[Page 140\]](#)

Deleting Items

Deleting Items

If you have entered an incorrect component number or item category, you must delete the item.

You can see the item overview.

1. Select the items you want to delete.
2. Click .

You see a dialog box with a security query.

If you confirm this query, the system deletes all the items you selected.



When you delete items, the system does **not** change the item numbers of the other items.

Delete items that have already been saved

If you want to delete an item that has already been saved the system carries out extra checks.

- In the following situations the item **cannot** be deleted:
 - It is not valid on the key date but in the future
 - Item has already been changed on the same day with reference to another change number
 - Item contains dependencies but the change number is not planned for dependency maintenance
- If you want to delete a material component that is assigned to an operation you will get a warning message.

Entering Sub-Items

Use

Sub-items are used to describe the different installation points of these partial quantities.

Prerequisites

In Customizing for *Bills of material* (work step *Item data* → *Define item categories*), you can define whether sub-items are supported for each individual item category. In the standard system, for example, sub-items are supported for the following item categories: Stock item Non-stock item Variable-size item PM structure element

Procedure

You can start the function for entering sub-items either from an item overview or from an item detail screen.

2. If you are on an *Item overview*, select the items for which you want to enter sub-items.

If you are on an item detail screen, start with step 2.

3. Click  *Subitem*.

You see the *Subitems* screen, on which sub-item numbers are already given.

4. Enter the subitems.

You can enter the following data:

- *Installation points*
- *Sub-item quantities*



The system compares the item quantity to the sum of all sub-item quantities. If the item quantity is different from the sum of the sub-item quantities, the system changes the item quantity.

You see the following information:

Item quantity changed from <old value> to <new value>

- *Sub-item description*

Enter a descriptive text for the sub-item (up to 40 characters).

5. If you have selected several items, you can switch between then sub-item overviews and the individual items using the  and  buttons.

6. Click .

Result

On the item overview, all the items that have sub-items have the *Sub-items exist (SIs)* indicator.

Once you have entered sub-items for an item, you can only change the component quantity on the sub-item overview.

Entering Sub-Items

No history is stored for sub-items. If a change to a sub-item quantity leads to a change to an item quantity, a new item record is created. The sub-items are maintained separately for each item record.

Deleting Subitems

You can delete subitems from the subitem overview.

To go to the subitem overview click  *Subitem*.



How to delete a sub-item:

1. Select the subitem(s) that you want to delete.
2. Click .

You see a dialog box with a security query. Confirm this query.

- Because the item quantity changes, the system displays the same message as for a change to the sub-item quantity. Confirm this query.
- The system deletes all the sub-items you selected. The sub-item numbers are not changed.

How to delete all sub-items for an item:

1. Select all subitems by clicking .
2. Click .

Confirm the query.

The item quantity is now 0, so the system goes to the *Quantity* field for the item (a required entry field). Enter a quantity other than 0.



When you delete **all** sub-items for an item, the item is not deleted. You can only delete items on the item overview.

Changing a BOM Header

Changing a BOM Header

You can go to the BOM header from various screens:

- Initial screen
- Item overviews
- Item detail

1. Click .

You can process header data on several tab pages:

- *Quantity/Long Text*
- *Additional Data*
- *Document Assignments*

See also:

[Maintaining header data \[Page 239\]](#)

2. After the changes save the BOM.

Change to a BOM Header: Example

The BOM for the Racing bicycle MRB01 (Plant 0001, Usage 01) is changed with change number CH01. The valid-from date for the change (07/01/1996) comes from the change number.

The alternative text of BOM MRB01 is changed. When you make a change with reference to a change number, the “old” value of the field is retained. The system creates a new BOM header for the BOM.

Before the change

Validity Period	
<i>Valid from:</i>	14.05.1998
<i>Valid to:</i>	01.07.1998
Alternative text	Blue model

After the change (change number CH01)

Validity Period	
<i>Valid from:</i>	01.07.1998
<i>Valid to:</i>	31.12.9999
Alternative text	Color model: blue frame



If you display the changed BOM over its entire validity period, you see two different header records in the *Header overview* for BOM MRB01 (Plant 0001, Usage 01).

Changing Classification Data

Changing Classification Data

How to change classification data for an item:

1. On the item overview, select the item whose classification data you want to change.
2. Click .
3. Change the values of the following fields on the *Basic data* tab page:
 - *Class types*
The class type must be defined for classifying the object type linked to the item. See [Classification Data \[Page 142\]](#).
 - *Indicator: Classification, selection condition*
If you delete this indicator, the classification data of the item is not taken into account when you configure the BOM.

Maintaining the Revision Level

You can assign a revision level to a material either by using engineering change management functions or when you are processing the material or the BOM for the material.

The section describes how to assign a revision level when processing a material BOM.

See also:

[Assigning a Revision Level to a Material \[Page 336\]](#)

[Changing a Revision Level \[Page 337\]](#)

[Displaying a Revision Level \[Page 338\]](#)

Assigning a Revision Level to a Material

Assigning a Revision Level to a Material

How to assign a revision level:

1. Process (create or change) the material BOM with reference to a change number.
2. Go to an item overview, item detail screen, or header detail screen.
3. Choose *Extras* → *New revision level*.

The system checks that no revision level has been assigned to the BOM header material for this change number.

- If no revision level has been assigned for this change number, the system determines the next revision level defined. You see a dialog box informing you which revision level is assigned to the BOM header material.

Save the BOM.

- If a revision level has been assigned for this change number, you see an error message. You can only assign a new revision level if you change the BOM header material with reference to a different change number.

Changing a Revision Level

You can only change the revision level assigned to a material from the engineering change management menu.

How to change a revision level for a material:

1. Choose *Revision level* → *Material revision level* → *Change*.
2. You see the initial screen. You can enter the material (BOM header material) for which you want to change one or more revision levels on this screen.

Confirm your entry.

3. You see an overview of all the revision levels assigned to the material so far, sorted by revision level.

You also see the following data:

- Valid-from data
- Change number
- Description of change number

You can sort the entries according to various criteria, for example, by date or change number.

4. Change one or more revision levels. To do this, overwrite the *RevLev* (*revision level*) field.



You can display possible entries for the sequence of revision levels defined for a material.

The system checks whether the new revision level you entered has already been assigned to a change with reference to another change number. If it has, you see an error message.

5. Save the changed revision levels.

Displaying a Revision Level

Displaying a Revision Level

This section describes how to display a revision level when processing a material BOM.

How to display a revision level:

1. You can display a revision level in any processing situation.
2. Choose *Extras* → *Display revision level*.

If a revision level has been assigned to the material, you see a dialog box with an overview of revision levels assigned so far, sorted by revision level.

You also see the following data:

- Valid-from data
- Change number
- Description of change number

You can sort the entries according to various criteria, for example, by date or change number.

Changing an Operation Allocation

The production processes for a product are described in routings. See [Allocating a Component to an Operation \[Page 236\]](#).

If a routing for the material does not exist, you can create a routing from the BOM change mode. You can also change an existing allocation (material component – operation).

You can change an allocation from the following screens:

- *Material* item overview
Select the item you want to allocate to an operation.
- Item detail screen of a specific item that you want to allocate to an operation.



The standard system does not support allocation to operations for the following item categories:

- Class item
- Document item
- Text item
- PM structure element

These items are deselected. The system displays a message telling you this.

How to change the allocation of a component to an operation:

1. Choose *Extras* → *Operation allocation*.
If no routing exists for the material, you see a dialog box in which you can decide whether to create a routing.
 - If you want to create a routing, confirm the query. You see the *Create routing: Initial screen*.
 - Enter the data you require and confirm your entries. The system makes a series of checks. If all your data is correct, you see the *Header Detail* screen.
Enter the header data you require for your routing.
 - To enter operations, choose *Goto* → *Operation overview*.
 - Define the work centers for processing.
 - Confirm your entries. You may see specific detail screens for the work center. Enter the necessary data on these screens.
If your data is correct, you return to the *Operation overview*.
If a routing exists, you see the *Operation overview*.
If the selected BOM item has not yet been allocated to an operation, the *Allocation exists* indicator (at the end of a line containing an operation) is not selected for any operation.
2. Select the operation to which you want to allocate your material component.
3. Choose *New allocations*.

Changing an Operation Allocation

The system allocates the operation you selected to the item you selected and selects the *Allocation exists* indicator at the end of a line containing the operation.

4. In the *Material components* menu, you can display the *General data* and the *Administrative data* of the allocated material components.
5. Once you have allocated the item to an operation, go back to the *Material* item overview by choosing *Back*. Save your changes in the BOM.



If you save your changes on the operation overview of the routing, you terminate BOM processing and you see the *Change material BOM* initial screen. Any changes you made in the BOM are still saved.

Changing a Variant BOM - Special Points

For information on options for changing variant BOMs, see [Options for Changing Variant BOMs \[Page 289\]](#).



If you want to change a variant part in one variant, choose *Material BOM* → *Change*.

If you want to change an item that is used with the same data in all variants (non-variable part, choose *BOM group* → *Change*.

Engineering change management

If you change a variant BOM with reference to a change number, you may see the following error message:

Please check the object management records

The reason for this is:

Different materials are allocated to the same variant BOM. This means that it is possible to create several object management records in a change master record for the BOM group.

You must select one object management record to represent all variants of the variant BOM.

See also:

[Object Management Records and BOM List \[Page 313\]](#)

Changing a Multiple BOM - Special Points

Changing a Multiple BOM - Special Points

For information on options for changing multiple BOMs, see [Options for Changing a Multiple BOM \[Page 302\]](#).

A multiple BOM groups together several alternatives. You can always only change **one** alternative at a time. For this reason, you must enter an alternative.



If you want to change a variant part in one alternative, choose *Material BOM* → *Change*.

If you want to change an item that is used with the same data in all alternatives (non-variable part, choose *BOM group* → *Change*.

Deleting a Material BOM

You delete BOMs in change mode. You can only delete one specific BOM at a time. You can only delete one alternative of a multiple BOM or one variant of a variant BOM.

You can delete a BOM with or without history.

Deleting without history

The selected BOM is deleted online. Once the delete transaction is updated, you can create a new BOM with the same *Material/Plant/Usage*.

Deleting with history

If you delete the BOM with reference to a change number, the system takes the valid-from data from the change master record as the deletion date. The BOM is deleted on this date.

Valid-from date of the change number

You can only use a change number with a valid-from date within the validity period of the BOM.

Example 1:

- BOM MAT is created with the valid-from date 05/01/1997.
- You want to delete the BOM with change number D1. The change master record has the valid-from date 01/01/1997.

You cannot delete the BOM with change number D1, because the BOM is not valid on **01/01/1997**.

Example 2:

- BOM MAT is created with the valid-from date 05/01/1997.
- You want to delete the BOM with change number D2. The change master record has the valid-from date 06/01/1997.

The BOM is deleted on 06/01/1997. The state of the BOM before the change (05/01/1997 to 05/31/1997) is retained. This means you can still process the BOM within this validity period.

Checking the BOM item

Before you can delete a bill of material, the system checks the BOM items as follows:

- Items with object dependencies
If a configurable bill of material contains one or more items with object dependencies, its change number must support dependency maintenance. The change number cannot be valid as of a date in the past.
- Items with operation allocation
If one or more items are allocated to an operation, you see a warning message.

Carrying Out the Delete Function

Carrying Out the Delete Function

There are two ways of deleting BOMs:

- Using the *Delete* function.
- Using the *Deletion indicator*.

How to delete a material BOM using the *Delete* function:

This deletes the BOM immediately or on the valid-from date of a change master record.

1. Enter the data to identify the BOM on the initial screen.

See also:

[Changing a Multiple BOM – Special Points \[Page 342\]](#)

[Changing a Variant BOM – Special Points \[Page 341\]](#)

If you enter a change number, do not enter a valid-from date.

2. Confirm your entries.
3. You see the item overview.
 - Choose *Material BOM* → **Delete**.
 - You see a dialog box with a security query. Confirm this query.
4. You see the initial screen again with the following message:

Alternative <alternative> of BOM for material <material number> deleted

Deleting a material BOM with the deletion indicator

If you select the deletion indicator, the BOM is archived in the next reorganization run, and can be deleted if required.

In the BOM header, you set the indicator that controls physical deletion after the archiving run. You can still process the BOM within its validity period.



This also applies if the deletion indicator is entered with reference to a change number with a valid-from date that is after the date of the next reorganization run.

For more information, see the R/3 Library, under *CA Cross- Application* → *Archiving and Deletion of Application Data*.

To set the deletion indicator for the next reorganization run:

1. Enter the data to identify the BOM on the initial screen.
2. Confirm your entries.
3. You see the item overview. Click

In the last dataset on the *Quantities/long text* tab page, under *Validity*, you see the *Deletion indicator field*. Select this field.

4. After the changes save the BOM.

Mass Changes

Mass Changes

Use

You can use the mass change function to change items in several BOMs at once.



Objects for Mass Change

The mass change function is controlled by the object type of the item you change (see [Item Entry and Master Record \[Page 137\]](#)).

For each object type, the system makes specific checks:

- Object type *Material*
 - This object type groups together all the item categories that refer to a material master:
 - Stock item
 - Non-stock Item
 - Variable-size item
 - PM structure element
- Object type *Document*
 - This object type groups together all the items that refer to a document info record (document items).
- Object type *Class*
 - This object type groups together all the items that refer to a class (class items).

Features

You can use a mass change to perform the following functions:

- Change
- Deleting items
- Creating items

Create

With this function you can create a new material item, document item or class item in several BOMs that contain a specific reference object.

The object type of the reference object and the new item is irrelevant. For example, you can create a document in all BOMs that contain a particular material item.

Delete

This function enables you to delete an item from several BOMs.

Enter the data that identifies the item you want to delete.

Change

This function enables you to:

- Replace an item in several BOMs
- Change item data.

To change the quantity, you can enter a factor to multiply with the required quantity of the old component.



If you set the *Relevancy to costing* indicator or the *Bulk material* indicator, an additional check is made, because these 2 indicators are mutually exclusive. If one of these indicators is set (for example, *Relevancy to costing*), and you want to set the other (for example, *Bulk material*) in a mass change run, the system deletes the indicator that was set before (*Relevancy to costing*, in this example).

Selecting BOMs

If you do not want to replace the BOM component in all BOMs, you can enter selection criteria for the BOM or item to include only the BOMs you want to change. Then a list of the selected BOMs is displayed. From this list you select which BOMs and items you really want to change.

See also:

[Starting a Mass Change \[Page 348\]](#)

[Executing a Mass Change \[Page 350\]](#)

[Reading the Log for Mass Changes \[Page 352\]](#)

Starting a Mass Change

Starting a Mass Change

To start a mass change:

1. Choose *Logistics* → *Production* → *Master Data* → *Bills of Material* → *Extras* → *Mass Changes*.

You jump to the *Mass Changes* screen: *Selection for Material*.

2. Select the object type for the reference object. If you want to start a mass change for a document or a class select *Document* and. *Class*.

The system automatically adjusts the selection criteria, the BOM categories and the item changes fields in the object type of the reference object.

3. Enter selection criteria in order to include the BOMs you want to change.

- Item data

- *Item category*

If the object is only to be replaced in BOMs where it has a certain item category, enter the item category. For example, you can replace a material component everywhere where it is defined in a BOM as a stock item.

- *Change number*

If you enter a change number, the system selects the change status that is valid on the date of the change number or on the alternative date.

Furthermore, the system carries out all changes with reference to this change number.

- *Valid from and Valid to dates*

Enter a valid from date or a time period. The system only selects items whose validity periods overlap with those that you have entered.



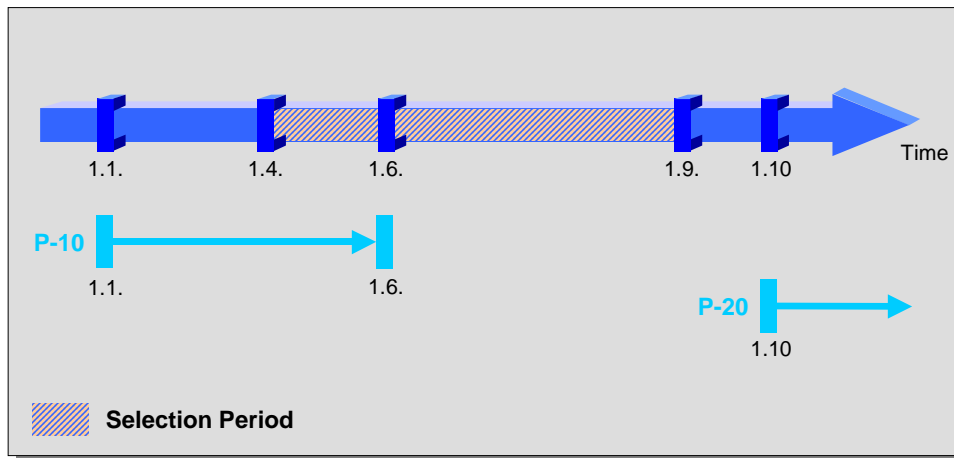

For example, you enter in the selection criteria the valid from date 1.4. and the valid to date 1.9. The system selects all item change statuses valid in this period.

Starting a Mass Change



- Item P-10 is effective between 1.1. and 1.6. It **is selected** because part of its effectivity falls within the period that you entered.
 - Item P-20 was created on 1.10. It is **not** selected because its effectivity does not start until after the end of the selection period (1.9.).
- BOM Data
 - *Use*
 - *Plant*
 - *Maximum Number* (only Material Items)
 - *BOM Number* (only Material Items)
4. Select the BOM categories to which you want to apply the mass changes.
 5. Select the function that you want to execute, for example, *change BOM data*.

The system automatically adjusts the fields for the item changes to the selected function.
 6. Enter the data for the item changes.
 7. Click on  to check the entries.
 8. Click .

The system selects a BOM that matches the selection criteria and displays it in a list.

See also:

[Executing a Mass Change \[Page 350\]](#)

Executing Mass Changes

Executing Mass Changes

When you have entered the reference object, as well as the BOM category, and if required, the selection criteria, the system displays a list of all the BOMs that meet the selection criteria entered.

1. Select the BOMs or items that you want to apply the mass changes to.

In the list you are able to switch between a header overview and an item overview for the individual BOMs.

In the header overview, the following data is displayed for each BOM selected by the system:

- BOM category (for example, material BOM)
- The identified BOM data (for example, *material, plant, usage for material BOM*)
If a bill of material is assigned to **several plants**, an asterix (*) is displayed in the place of the plant. If it is, there is only **one** BOM for all plants. Any change you make in one plant is valid in all of the other plants, too.
- Internal BOM number
- Alternative BOM

In the overview, the system always displays all multiple BOM alternatives for which a reference object exists. All multiple BOM alternatives are displayed in a highlighted block. Select the alternatives for which you want the change to be made.



- Item number, item category and item ID of the item to be changed

If the reference object (for example, material) is **used several times** in a BOM (for example, as item 0010, 0044, 0070), an asterix (*) is displayed in the place of the item data. Double click on the entry to display the item overview for this BOM. In the item overview, you can decide whether to change each individual item.

The selected items of **one** BOM are displayed in the item overview.

- By clicking on the ◀ and ▶ buttons, you can scroll between the item overview and the individual BOMs.
- If you select only part of the item in the item overview, then the indicator for the entire BOM is not available in the header overview. In this case, you can only maintain the indicator for this BOM in the item overview.

Additional Activities in the Selection List

Pushbutton	Function
	Go from a header overview to an item overview
	Go from an item overview to a header overview
Select BOMs	Select all alternatives of a multiple BOM

Executing Mass Changes

<i>Deselect BOMs</i>	Deselect all alternatives of a multiple BOM
<i>Plant Assignments</i>	Display all BOM plant assignments.  If the BOM is assigned to several plants, the change is made in all of them.

2. Choose the processing function.

Result

The system automatically changes the BOMs and items selected. When the system has executed all changes, a log appears informing you about the system's activities.

See also:

[Reading the Log for Mass Changes \[Page 352\]](#)

Reading the Log for Mass Changes

Reading the Log for Mass Changes

You receive this log automatically. It informs you of the changes that have been made.

- If a BOM was changed successfully, the log contains a description of the changes as well as the following log entries for the BOM material:

BOM for <material> <plant> changed

- If a change was **not** made, the log contains an error message. This BOM may, for example, be locked because it is being processed by another user.

The log also contains the name of a background session that you can use to process the BOMs that have not been changed. This session contains a sequence of transactions for changing BOMs, for example, *Change Material BOM* or *Change Material BOM Group*.

- A program puts the data of BOMs that were not changed correctly into the session. You can then process this session at a later date online. The database is not changed until the session is processed.
- If you want to process the session, choose *System* → *Services* → *Batch Input* → *Sessions*.

You go to the screen *Batch-Input: Session Overview*, where you can select the sessions you want to process.

- When you process the session, the system automatically runs the transactions defined and enters the necessary data in the screens.

BOM Reporting Functions

Use

This section describes the range of reporting functions for BOMs.

Features

The R/3 System supports the following reporting functions:

[BOM Explosion \[Page 369\]](#)

[Where-Used List \[Page 398\]](#)

[BOM Comparison \[Page 414\]](#)

You can choose from two different layouts:

- SAP List Viewer (ALV)

In this layout, the reporting list is displayed in the form of a table.

See: [SAP List Viewer \(ALV\) Grid Control \[Ext.\]](#)

- Variable List

In this layout, the display of the reporting list is flexibly controlled by a display profile. You can use the standard profile provided with the standard SAP System, or you can define your own display profile to adapt the list to your requirements. Each profile can be displayed on the screen as well as printed out. For more information, see [Display Profile For Lists \[Page 355\]](#).

Furthermore, there are additional functions for the extension of the view available to you in the variable list. For more information, see [Extending the View for BOM Explosion \[Page 383\]](#).

Activities

You can find the BOM reporting functions in the SAP menu under *Logistics* → *Production* → *Master data* → *BOMs* → *Reporting*

You activate the variable list as follows:

1. On the initial screen of the appropriate reporting function, click .

The *View* screen appears.

2. Set the *Variable List* indicator.

The system shows the additional fields for display profiles and extending the view.

User-Specific Settings for BOM Reporting

User-Specific Settings for BOM Reporting

Use

You can define user-specific default values for BOM reporting functions and where-used lists, by choosing *View*.

Procedure

How to define user-specific values:

You can use this function on any of the initial screens, for example, *BOM explosion*. *BOM level by level*.

1. Choose *Settings* → *Reporting*.

The *Settings: Reporting* dialog box appears.

2. Enter whether you want to use the variable list as standard.
3. Select the indicator for the print request screen if required.

If you select this indicator, you see the print request screen when you call a print function, so that you can check it and change it if necessary. All default values maintained for the user are predefined.

If you do not select this indicator, the system executes the print job according to the predefined defaults.

4. Set the indicators that control the BOM explosion.

- *Display sub-items*
- *Sub-assemblies*
- *Objects from classes*

See [Extending the View for BOM Explosion \[Page 383\]](#)

5. Set the indicators that control the where-used lists.

- *Direct*
- *Via classes*

See [Defining a Where-Used List on the Initial Screen \[Page 399\]](#)

6. Choose *Copy*.

Display Profile for Lists

Use

Lists produced by BOM reporting functions are displayed according to list profiles. These list profiles are used for:

- Screen display
- Printouts



The functions described here are only available for [Variable Lists \[Page 353\]](#).

Features

In the standard R/3 System, each reporting function has a standard list profile that provides default values for display profiles. To create another reporting list, you create a new profile. You use the display blocks of the standard profile to do this.

List names

The content and layout of a reporting list are determined by a list profile. All profiles for one transaction (for example, *Explode BOM* → *BOM level by level*) are allocated to a *List name*.

The following objects are allocated to a list name:

- **Maximum block**

A reporting list is made up of several sections (display blocks). A maximum block contains all the fields allowed in a display block, for example, all the fields of the list header and all the fields of a heading. Maximum blocks are defined internally in the SAP R/3 System and cannot be changed.



If you create enhancements – additional fields in BOM tables (for example, STPO – BOM item) – the maximum block is not extended. This is why you cannot copy these fields to the list.

- **List profiles**

A list profile groups together all **display blocks** (for example, list header) that define the layout of a specific reporting list (for example, *BOM level by level*). You can have several list profiles for a reporting function, which display the result in different ways.

The profiles for producing lists in the standard R/3 System are known as **standard profiles**.

Field attributes are maintained for the fields in a display block. You can change these as required (for example, move or delete a field). The fields in a display block are a subset of the fields in the maximum block.

Display Profile for Lists

Default Values for the Display Profile

When you use a BOM reporting function, the view settings define the display profile for the resulting list. The display profile contains one of the following default values:

- [Standard Profiles for Reporting Lists \[Page 357\]](#)

In the standard R/3 System, reporting lists are produced according to standard profiles.

- User-specific list profile

You can change the standard profiles as you wish, to produce variable reporting lists. You can define these new list profiles as default values for certain users.

See also:

[Maintaining a New List Profile \[Page 358\]](#)

[Entering User Defaults for a List Profile \[Page 366\]](#)

Authorization Check

Authorization object [C_VARLIST \(Objects for Variable Lists\) \[Page 25\]](#) lets you restrict maintenance of objects in variable reporting lists.

Standard Profiles for Reporting Lists

Each BOM reporting function has its own profile (standard profile). When you call a reporting function in the standard R/3 System, this standard profile is the default for all users.



If you define a new list profile, you can set up the system so that the new profile is copied as the default for certain users. See [Entering User Defaults for a List Profile \[Page 366\]](#)

The following tables show the standard profiles for the individual reporting functions.

Standard profiles for BOM explosions

Function	Standard profile
BOM level by level	SAPCSLBLMP01
Multi-level BOM	SAPCSMLVMP01
Summarized BOM	SAPCSSMXMP01

Standard profiles for where-used lists

Function	Standard profile
Material where-used list	SAPCSWSDMP01
Document where-used list	SAPCSWSDDP01
Class where-used list	SAPCSWSDCP01

Maintaining a New List Profile

Maintaining a New List Profile

If you want to create a reporting list that is different to the standard, you create a new profile. To do this, you use the display blocks of the standard profile as a template. For example, for reporting function *Explode BOM* → *BOM level by level*, you can use standard profile SAPCSLBLMP01.

You can redefine each line of the list, for example:

- Create a new list header
- Define the position and size of frames

To create a new list profile, perform the following activities:

1. [Creating a New List Profile \[Page 359\]](#)
2. [Displaying the Standard Profile \(Display Blocks\) \[Page 360\]](#)
3. [Creating Display Blocks for the New Profile \[Page 363\]](#)
4. [Processing New Display Blocks \[Page 364\]](#)
5. [Checking a New Profile \[Page 365\]](#)



If you define a new list profile, you can set up the system so that the new profile is copied as the default for certain users. See [Entering User Defaults for a List Profile \[Page 366\]](#)

Creating a New List Profile

First, you only define the technical name of the new list profile. In a second step, you edit the display blocks.

1. In Customizing for *Production*, choose *Basic Data* → *Bill of Material* → *Tools* → *Define display profile*.
You see the variable lists screen.
2. Choose *Profile*.
3. Enter a technical name for your list profile (for example, **AD-CSLBLMP01**), then choose *Create*.
4. Enter the basic data for your list profile:
 - Description
 - Width for the list
In the standard profile, the width of the list is **79**. If you choose a different value for your profile, you must edit each display block of the profile.
5. Save your list profile.
You return to the initial screen.

Displaying the Standard Profile (Display Blocks)

Displaying the Standard Profile (Display Blocks)

The display profile in the standard R/3 System (standard profile) contains all the display blocks for a reporting list. You need to use these display blocks to create a new list profile. This is why you display all the display blocks in the standard profile:

1. In Customizing for *Production*, choose *Basic Data* → *Bill of Material* → *Tools* → *Define display profile*.
2. Choose *Profile*.
3. Enter the name of the standard profile (for example, SAPCSLBLMP01). See [Standard Profiles for Reporting Lists \[Page 357\]](#)
4. Set the *Standard object* indicator.
5. Choose *Extras* → *Hierarchy explosion*.

You see **all** the display blocks of the standard profile. See [Display Blocks: Example \[Page 362\]](#)

In the *ID* column, the display blocks are identified by the ID value **4**.

- *List object* column

The first column contains the name of the list object. If you change a display block, you must assign a new name to the list object. See [Creating Display Blocks for the New Profile \[Page 363\]](#)

- *Block name* column

The *Block name* column contains the technical name of the display block. This name is defined internally. You cannot change it.

6. Check the display blocks, and select the display blocks you want to change.

To display a screen template:

- Select the display block you require, then choose *Display block*.
The fields are displayed in schematic form.
- To see the field description, select the F1 help.

7. You need to refer to the list of display blocks to continue processing.

How to proceed depends on your working situation:

- To print the list, choose *Print*.
- To continue processing, create a new session.

8. Make a note of the display blocks (names of list objects) that you want to:

- Use **as they are**
(For example, heading SAPCSLBLMM02D01 for LISTHDNG)
- **Change**
(For example, list header SAPCSLBLMM01D01 for LISTHDR)

9. Choose *Back*.

Displaying the Standard Profile (Display Blocks)

Display Blocks: Example

Display Blocks: Example

For example, the standard profile SAPCSLBLMP01 has the following display blocks:

List object	Block name	Description
SAPCSLBLMM01D01	LISTHDR	List header
SAPCSLBLMM02D01	LISTHDNG	Heading
SAPCSLBLMM03D01	ITEM_M	Material item
SAPCSLBLMM04D01	ITEM_D	Document item
SAPCSLBLMM05D01	ITEM_C	Class item
SAPCSLBLMM06D01	ITEM_NOO	Item without object (for example, text item)

Creating Display Blocks for the New Profile

All the display blocks in the standard profile must exist in the new profile as well. You use the display blocks in the standard profile for the new profile.



All the display blocks in the must have the same block names as in the standard profile, regardless of whether you changed the display block.

1. In Customizing for *Production*, choose *Basic Data* → *Bill of Material* → *Tools* → *Define display profile*.
2. Choose *Profile*.
3. Enter the new profile (for example, AD-CSLBLMP01).
4. Choose *Copy blocks*. You see a dialog box where you allocate the new profile to the standard profile.
 - The system automatically copies the new profile (for example, AD-CSLBLMP01) to the *Profile for block allocation* field.
 - In the *Copy from* field, enter the standard profile whose display blocks you want to copy (for example, SAPCSLBLMP01).
5. Confirm your entries. You see a list of all the display blocks in the standard profile.

At the end of each line, you can select one of the following:

- **A (Assign block)**
 - If you want to use the display block as it is, select **A**. The system automatically allocates the display block to the new one.
 - A** is selected as the default for all display blocks.
 - **C (Copy block)**
 - Select **C** for the display blocks that you want to **change**. The system copies the display block.
6. Confirm your selection.
 - You see a dialog box, where you assign new names to the display blocks (for example, AD-CSLBLMM01D01 for the list header).
 - Once you have assigned a new name to each of the display blocks that you want to change, the system displays the list of display blocks again.
 - If you want to use a display block as it is, simply leave the default value **A (Assign block)**.
 7. Save your entries.
 - The system allocates the changed display blocks and those that you want to use as they are to the new profile. In addition, it automatically allocates the new profile to the list ID of the standard profile.

You return to the *Variable Lists: Initial Screen*.

Processing New Display Blocks

Processing New Display Blocks

You can process the new display blocks from the structure list of the new profile.

1. In Customizing for *Production*, choose *Basic Data* → *Bill of Material* → *Tools* → *Define display profile*.
2. Choose *Profile*.
3. Enter the new profile (for example, AD-CSLBLMP01).
4. Choose *Extras* → *Hierarchy explosion*.

You see a list of all the display blocks of the new profile.

5. Place the cursor in the line of a display block that you want to change (for example, AD-CSLBLMM01D01). Choose *Choose*.

You see the initial screen of the function for maintaining a display block. The identifying name of the display block (for example, AD-CSLBLMM01D01) is now shown in the *Display block* field.

6. Choose *Change*.

You see the basic and administrative data. To display all the fields of the display block, choose *Continue*.

7. Change the field attributes as required. For example, you can move or delete a field.

Example: Delete block (for example, the BOM usage field)

- Go to the block.
- Choose *Select block*.
- Choose *Edit* → *Delete selected fields*.

8. Check the value in the *Text* field in the individual datasets.

The value *blank*, for example, is a field content, whereas the value *1* is a short text.

When deleting data, make sure that you delete all data. For example, you may have to delete a field text from the heading or a field value or underscore from another dataset.

9. Save the changes you have made to the display block.

You return to the hierarchy explosion, from where you can display the sample screens of individual display blocks in schematic form by choosing *Display block*.

Repeat this process for all the display blocks that you want to change.

Checking a New Profile

From the hierarchy explosion, you can only display each display block individually, without seeing its field values. Once you have changed all display blocks, you should therefore check the entire list profile.

1. To do this, carry out the application function (for example, *Explode BOM* → *BOM level by level*).
2. Choose *View*, then enter the new list profile (for example, AD-CSLBLMP01).
You see the reporting list.
3. Check that the display blocks are correct.

If you want to correct a display block, proceed as follows:

Choose *Define display profile for lists* again. See [Processing New Display Blocks \[Page 364\]](#).

Entering User Defaults for a List Profile

Entering User Defaults for a List Profile

In the standard R/3 System, standard profiles for BOM explosions and where-used lists are the default for all users of reporting lists.

If you want to use your own display profiles for variable lists in your company, you can define user-specific defaults for the list profile of all lists. The reporting programs then ignore the standard profile for the user. See [Standard Profiles for Reporting Lists \[Page 357\]](#).

Before you start

In Customizing for *Production*, under *Bill of material* → *Tools* → *Define user defaults for list display*, you must define the list profile for variable lists in the reporting function (for example, *BOM level by level*).

Procedure

1. In Customizing for *Production*, choose *Bill of material* → *Tools* → *Define user defaults for list display*.
2. Enter the name of the user for which you want to define a default value for list display.
3. Enter the program for which you want to copy a list profile as a default value.
See [Program Names for Reporting Functions \[Page 367\]](#).
4. Enter the profile that you want to define as the default value for this reporting function, for the user you selected.
5. Define the profile mode, for example, PRNT for printouts.
6. Save your settings.

Result

When the user you selected calls the reporting function, the list profile you entered determines the default values in the *Print* view.

Program Names for Reporting Functions

The following overview shows the program names for BOM reporting functions.

Function	Program name
BOM level by level	RCS11001
Document structure level by level	RCS11011
Multi-level BOM	RCS12011
Summarized BOM	RCS13001
Material where-used list	RCS15001
Document where-used list	RCS15011
Class where-used list	RCS15021

Printing Reporting Lists

Printing Reporting Lists

Use

You use this procedure to print out a variable list.

Procedure

You can print the lists you produce with BOM reporting functions at any time. For more information on printing, choose *Help* → *Getting started*.

Using the *Print request screen* in the user-specific settings, you can define whether it is possible to make an entry in the dialog box for print parameters.

See [User-Specific Settings for BOM Reporting \[Page 354\]](#)

How to print reporting lists:

1. Click .
2. Depending on the user-specific values defined, either you see a dialog box for print parameters or the system prints the list according to the predefined defaults.
 - If you see a dialog box for print parameters, enter the print parameters you require, for example, the printer. Choose *Continue*.

Batch Requirement

You also have the option to print the list in the batch. This enables you to plan your print for a later date and to control the reporting using various selections.

For the batch requirement, you need the program name. The table below lists the functions of the corresponding programs.

Function with Program Description

Function	Program
BOM level by level	RCS11001
Document structure level by level	RCS11011
Multi-level BOM	RCS12001
Summarized BOM	RCS13001
Material where-used list	RCS15001
Document where-used list	RCS15011
Class where-used list	RCS15021

For detailed hints of the procedure, see the document *ABAP/4: Generate lists* (R/3 Library, under *Basis*).

BOM Explosion

Use

A BOM explosion answers the question: **What is the product made of?** This question arises in various situations, such as when you want to:

- Determine material requirements for a product
- Look at the overall structure of a product in a design department
- See an overview of the parts and materials required
- Calculate the effects of changes to costs

Features

When you explode a BOM “top down”, the system finds all the components that are in the BOM. Some individual components may also be assemblies. These subordinate BOMs are included in reporting functions. There is no limit to the number of levels of BOMs you can have.

You can use selection criteria to either include additional information or restrict the list displayed, so you can define precisely how you want to explode a BOM.

BOM Categories

The BOM explosion is available to you for the following BOM types:

- Material BOMs
- Order BOMs

You can find more detailed information about the BOM explosion for order BOMs in the documentation for order BOMs under [Multi-Level Order BOM Reporting \[Ext.\]](#).

- Work breakdown structure BOMs

How do you explode a BOM?

For each individual BOM type various reporting functions are available:

- For the structural explosion:
 - *BOM level by level*
 - *Multi-level BOM*
- The summarized BOM function is a quantity-based reporting function.

See also:

[BOM explosion level-by-level \[Page 385\]](#)

[Multi-level BOM explosion \[Page 387\]](#)

[Displaying a Summarized BOM \[Page 389\]](#)

Alternative Determination Using the Application

Alternative Determination Using the Application

A material can have several BOMs with different BOM usages, such as production, sales, and costing.

A BOM for a specific BOM usage (such as production) can also have several alternatives, if the BOM is a multiple BOM.

By entering an *Application*, you can target your explosion of a BOM for one specific area within the company (such as sales).



In your user master record, you can define a default value for the *Application* field. This value is defined as a SET/GET parameter. When you start the BOM function, the value you see in this field is the default value from your user master record. Then you see the last value that was entered.

To define this setting in your user master, choose: *System* → *User profile* → *Own data*. Enter the application you require for parameter CSA (application).

Defining an Application

In Customizing for *Production*, you define the procedures for automatic alternative determination in your company by choosing *Bill of Material* → *Alternative Determination* → *Define applications*.

The application is the key to the following criteria for the search process:

- Priority of BOM usage
- Priority of a specific alternative in a multiple BOM
- Production versions from the material master record
- Checks for specific status indicators for different application areas

The following sections use examples to illustrate these criteria.

Priority of BOM usage

In Customizing for *Production*, you can define a priority sequence of BOM usages for an application by choosing *Bill of Material* → *Alternative Determination* → *Define order of priority for BOM usages*.



For application SLDB (sales), the highest priority usage is *sales*. The next usage in the sequence is *production*. If there is no valid BOM with the usage *sales*, the system looks for a BOM with the next usage defined in the order of priority –*Production*, in this example.

If no valid BOM exists with any of the usages defined in the priority sequence, the BOM is not exploded.

When you define an application, note the item status indicators defined for the usages you select. For example, if you define an application for sales, include the usages that allow items to be relevant to sales. Otherwise, when you process a sales order using the application the system cannot find any components because there are no items relevant to sales.

Priority of specific alternative

In Customizing for *Production*, you can define for one BOM which alternative the system is to select as of a specific date by choosing *Bill of Material* → *Alternative Determination* → *Define alternative determination for multiple BOMs*. This setting applies to one BOM only, which you identify by entering the *Material*, *Plant*, and *Usage*.

You can use the *Alternative selection for multiple BOMs* indicator to define the application so that the alternative entered is used, provided that the material master allows alternative determination by explosion date (*Alternative selection* field must contain the value **1**).



If the application is defined in such a way that a specific alternative has priority, the lot size is not checked.

Defining an Application



For BOM MAT04/Plant 0001/01, the entry in the alternative selection field determines that alternative 03 is always selected as of 07. 01.1996.

- One application (for example, STD1 – Standard 1) is defined in such a way that this field entry is used.
- However, another application (for example STD2 – Standard 2) ignores this field entry, and selects an alternative that is valid according to date and status. The lot size is not checked.

Production versions

You can use the *Production versions* indicator to define an application in which production versions for the material influence automatic alternative determination.

If the *Alternative selection* field in the material master contains the value **2**, production versions are used in automatic alternative determination. The lot size is always checked.

Production versions allow you to define the following criteria for selecting an alternative BOM:

- Alternative BOM
- BOM usage



If you define an application in which production versions are not used, the system only checks the lot size.

Status indicators

Only an alternative that contains the required indicators in the application is selected.



For example, if you set the *Explosion in MRP* indicator when you define an application, only an alternative that has this indicator in its BOM status can be selected.

Selecting a BOM for the Explosion

When a BOM is exploded, the system checks the material master record of the header material (*Basic Data* view). The *Valuate effectivity* indicator influences the possible entries for the explosion.

- If this indicator is **not** set in the material master record, the BOM is exploded according to the *Valid-from* date.
- If the indicator is **set** in the material master enter the effectivity requirements for the explosion in the *Valuate effectivity parameter* dialog box.

Selection Criteria

The following selection criteria influence which BOM is selected:

- *Valid-from date*

You must enter a valid-from date if you have processed the material BOM several times with change numbers that have a valid-from date defining their effectivity (the SAP System standard). This gives rise to several effectivity periods.

If you enter a change number, the system determines the valid-from date from the change master record.
- *Change number*

If you enter a change number, you display the version of the BOM that is effective for this change number.
- *Revision level*

If you enter a revision level, the system finds the related change number and displays the version of the BOM that is effective for this change number.
- *Required quantity*

If the BOM is a multiple BOM, you see the alternative for the lot-size range that corresponds to the required quantity. If you do not enter a required quantity, the base quantity is automatically the required quantity.

See also:

[Selecting the Effective Version of a BOM \[Ext.\]](#)

[Entering Effectivity Parameters \[Page 374\]](#)

Entering Effectivity Parameters

Entering Effectivity Parameters

Use

You can use change master records that have parameters for effectivity (such as a range of serial numbers) to process bills of material.

You can enter values for effectivity parameters (for example, serial number range) in the following reporting functions:

- BOM explosion level by level
- Displaying a Multi-Level BOM Explosion
- Summarized BOM
- BOM Comparison

Prerequisites

In the material master record of the BOM header material (*Basic data view*), the *effectivity assignment* indicator is set.

Procedure

1. From the bills of material menu, choose a reporting function (for example, *Reporting* → *Explode BOM* → *Material BOM* → *Level by level*).
2. Enter the data that identifies the BOM on the initial screen.
3. Choose *Proceed*.

The dialog box *Effectivity parameter assignment* is displayed.

4. Enter the following values for the explosion:

- Parameters

You can enter both the standard system parameters for effectivity types time period and serial number range, and any company-specific parameters for effectivity.

This procedure ensures that you can explode the BOM with the parameters you require right down to the bottom level, even if you have used change numbers with different effectivity types to change BOMs.

- Indicators for release status

These indicators are only read for change master records that have a release key with the corresponding indicator.

By selecting the release key indicator, you define the release status that the BOM must have in order to be displayed. For example, you display the change state or version that is released for planning and production.

See also: [Effective Change Status Selection \[Ext.\]](#)

5. Choose *Continue*.

Result

You see the list of data produced by the function you chose (for example, *BOM level by level*).

See also:

[When is a Material BOM Not Exploded? \[Page 396\]](#)

[When is a BOM Explosion Terminated? \[Page 397\]](#)

[Working with Parameter Effectivity \[Ext.\]](#)

[Create a Parameter Variant \[Ext.\]](#)

[Override Effectivity with Change Numbers \[Ext.\]](#)

Selection Criteria for BOM Explosion

Selection Criteria for BOM Explosion

To ensure that your BOM explosion only contains the information you require for your application area, you can use selection criteria in reporting functions. You define these selection criteria on a special screen. To see this screen, click .

Using the *Variable List* indicator, you choose the layout of the list. If you set this indicator, the system displays the additional function fields that are only available for variable lists.

See also:

[Defining a View for BOM Explosion \[Page 377\]](#)

[Restricting the View for BOM Explosion \[Page 380\]](#)

[Extending the View for BOM Explosion \[Page 383\]](#) (part of the functions only in variable lists)

[Display Profile for Lists \[Page 355\]](#) (only variable lists)

Defining a View for BOM Explosion

You can use the following indicators to influence the BOM explosion:

- *Alternative priority*
- *Scrap*
- *Sort*

Alternative priority

When you explode a BOM, this indicator determines that the system only searches for the alternative you enter in the *Alternative* field in multiple BOMs.



Material A has a multiple BOM, as shown in the following graphic:

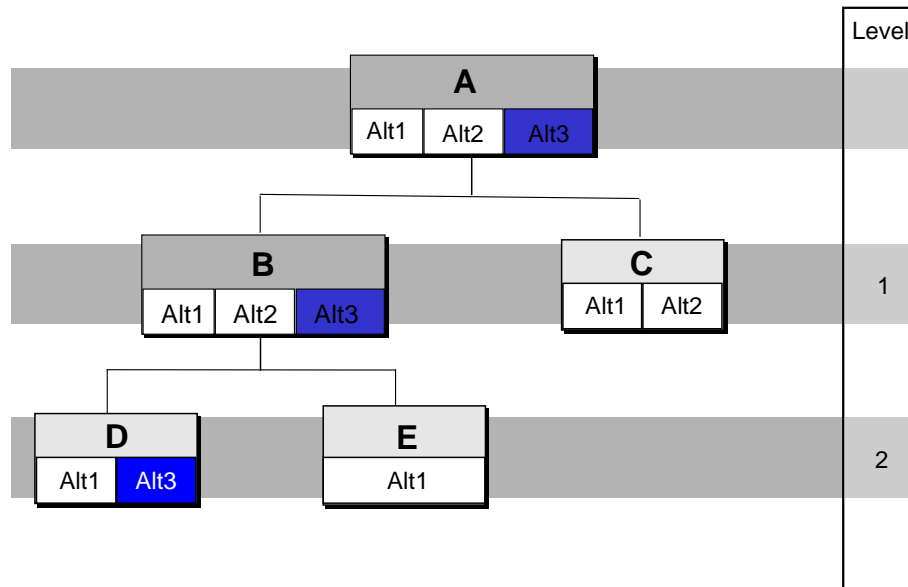

The following table illustrates two different explosions of this multiple BOM, produced according to different selection criteria.

Explosion with Alternative Priority

Your selection criteria in these fields	Produces an explosion as follows:
<i>Alternative:</i> 03 <i>Alternative priority:</i> X	Explosion continuously to level 2
<i>Alternative:</i> 02 <i>Alternative priority:</i> X	Only to level 1

Defining a View for BOM Explosion

Scrap

This indicator affects how the component quantity is calculated as regards scrap values. If you want to take scrap into account, the system increases the required quantity by the scrap factor defined. If this puts the required quantity in a different lot size, the system determines a different alternative, provided that the material master supports selection according to order quantity (*View MRP 2, Alternative selection* field, value **Blank**).

The following scrap values are relevant:

- Assembly scrap, which may be overridden by operation scrap
- Component scrap

If assembly scrap is maintained for an assembly in its material master, the system applies this scrap factor to all components of the assembly (with the exception of components that have operation scrap). Component scrap only affects an individual component.



Material **A** has an assembly scrap factor of 10 % and a multiple BOM with the following alternatives:

Alternatives with Lot Size

Alternative	From lot size	To lot size
01	1	1000
02	1001	2000

The required quantity entered for the BOM explosion is 1000.

If you do not take scrap into account, the system explodes alternative 01. If you set the scrap indicator, the required quantity is increased by the scrap amount (1000 + 100), and the system explodes alternative 02.

Sort

For a summarized BOM, you can enter a sort procedure in this field for the BOM components. You can sort the components according to the following criteria:

- Object number (value **Blank**)
- Object description (value **1**)
- Sort string (value **2**)



The following overview shows the components of BOM **A**.

Components of BOM A

Item number	Component	Quantity	Sort string
-------------	-----------	----------	-------------

Defining a View for BOM Explosion

0010	B	12	Bolt
0020	B	10	Bolt-01
0030	D	10	
0040	E	10	
0050	F	30	Bolt

If you do not take the sort string into account (*Sort string* field with value **Blank** or **1**), items 0010 and 0020 are displayed as one item with a sum quantity of 22.

If you do take the sort string into account (*Sort string* field with value **2**), items 0010 and 0020 are displayed separately. The system sorts the items in ascending order according to the sort string (0030, 0040, 0010, 0050, 0020).

Restricting the View for BOM Explosion

Restricting the View for BOM Explosion

Defining the Scope of the BOM Explosion

You can either display an entire BOM or a restricted-scope BOM. To determine the scope of a multi-level BOM explosion, set the *Limited explosion* indicator.

To determine the scope of the BOM explosion:

- If you want to display the entire BOM, do **not** set the *Limited explosion* indicator.
- If you want to restrict the scope, set the *Limited explosion* indicator.

If you do this:

- Assemblies **kept in stock** are only displayed and not exploded.

Exceptions:

Assemblies that have special procurement key **50** defining them as *phantom assemblies* are always displayed and exploded. The explosion does not depend on the values of other attributes.

Assemblies that have special procurement key **52** defining them as *produced directly* are handled in the same way as phantom assemblies – displayed and exploded.

- Items that are **not kept in stock** are displayed and exploded.



If you do not set any other indicator in the *Restrict view* dataset, the system displays all the components found.

However, if you only want to display specific items, you can enter the item status indicators and BOM item field values.

Filtering Items for BOM Display

You can either display all the items in the BOM you want to explode, or filter the BOM so that it only includes certain items. You can filter items according to item status indicators or by entering certain field values.

There are 2 steps to exploding a bill of material:

1. The system explodes the entire BOM – irrespective of the selection criteria entered. This happens in the background.
2. The system reads the selection criteria entered, such as the *Item relevant to engineering/design* indicator. This status indicator works as a filter. The explosion result that you see on the screen shows only the items that meet the selection criteria entered. For example, only the items that are relevant to engineering/design are displayed.

To filter items by item status indicators:

- If you want to display **all** the items in the BOM, do not set any indicators in the *Restrict view* dataset.
- If you only want to display only **certain** items in the BOM, set one of the following indicators:

Restricting the View for BOM Explosion

- Item **relevant to engineering/design**
 - Item **relevant to production**
 - Item **relevant to plant maintenance**
 - **Bulk material**
 - **PM assembly**

PM assemblies are not exploded down further in BOM reporting functions.

To select items by specific field values:

- Item category
The system only displays items with the item category you enter.
- Relevancy to costing
The system only displays items that are relevant (or not relevant) to costing.
- Relevancy to sales
The system only displays items that are relevant (or not relevant) to sales and distribution.
- Spare part indicator
The system only displays items that are allocated to a spare part group and that have a specific spare part indicator.
You define groups for spare parts in Customizing for *Bills of Material*.
- Spare part selection
Items that have **any** spare part indicator
 - If you want to display all spare parts, enter X.
 - If you want to display spare parts that are relevant to production, enter 1.
 - If you want to display spare parts that are not relevant to production, enter 2.
- Material provision indicator
Items that have a specific material provision indicator.
You define groups for materials to be provided in Customizing for *Bills of Material*.
- Material provision selection
Items that have **any** material provision indicator
 - If you want to display all materials to be provided, enter X.
 - If you want to display materials that are provided by a customer, enter 1.
 - If you want to display materials that are provided by a vendor, enter 2.
- Assembly
If you enter an assembly, the display is filtered so that you only see the data of the assembly.
- Component

Restricting the View for BOM Explosion

If you enter a component, the system displays a summarized BOM just for this component.

Extending the Views for BOM explosions

You can obtain additional information on items by selecting one of the following indicators:

- **Long text** (only [Variable Lists \[Page 353\]](#))

If you set this indicator, you see the complete long text for each item.

- **Sub items** (only variable lists)

This function is supported for level-by-level BOMs and multi-level BOMs. If an item has sub-items, the system displays the sub-items with the item.

- **Multi-level**

This function is supported for level-by-level BOMs.

- If you set this indicator, the system displays the items that are assemblies exploded down to the lowest level.

The list displays all the components on the first level first. Components that are assemblies have an indicator next to them, but they are not exploded down immediately. There is a dividing line below the last component on each level. The next level is displayed in the next block.



Exceptions occur if you have set the *Limited explosion* indicator. See [Restricting the View for BOM Explosion \[Page 380\]](#)

- If you do not set this indicator, the list only displays the items on the first explosion level (single-level explosion).

- **Sub-assemblies**

This function is supported for summarized BOMs.

You can use this indicator to control multi-level display as follows:

- If you want to display all sub-assemblies, set this indicator. The list then contains both sub-assemblies and their components.
- If you only want to display the individual components of the BOM, do not set this indicator.



A BOM contains sub-assembly A-A, with components C-1 and C-2.

If you set this indicator, the summarized BOM shows both the data of sub-assembly A-A and the data of components C-1 and C-2.

If you do not set this indicator, you only see the data of components C-1 and C-2.

- **Display objects from classes** (only variable lists)

If you want the reporting list to show all objects allocated to a class item, set this indicator. You see the objects allocated to the class directly after the class item display block.

Extending the Views for BOM explosions

BOM Explosion Level by Level

Use

This BOM reporting function shows which components make up the individual assemblies across the product structure. Components that are also assemblies are exploded lower down.



This reporting function is available to you for the following BOM types:

- Material BOMs
- Order BOMs
- Work breakdown structure BOMs

Prerequisites

The *Multi-level* indicator is set in the data for [Extending a View for BOM Explosion \[Page 383\]](#).

Procedure

1. In the SAP Easy Access Menu select *Logistics* → *Production* → *Master data* → *Bills of material* → *Reporting* → *BOM explosion* → <BOM type> → *Level by Level*.
The *BOM Level by Level: Initial Screen* appears. *Initial screen*.
2. Enter the data that identifies your BOM (such as *Material*, *Plant*, and *Alternative*, if appropriate).
3. In the *Application* field, enter the key of the procedure for automatic alternative determination.
4. Enter the data for [Selecting a BOM \[Page 373\]](#).
5. Click  to determine the selection criteria for the BOM explosion.
See also: [Selection Criteria for BOM Explosion \[Page 376\]](#)
6. Click .

Result

You see a list of all items that fulfill your selection criteria. The quantities refer to the required quantity displayed in the list header.

- In the reporting list for *BOM level by level*, you first see all components on the first level. Components that are assemblies have an indicator in the *Asm* (*assembly*) field. However, they are not exploded down immediately.

A dividing line shows where the next explosion level begins.

- If a component is also an assembly, the system explodes the next level (for example, level 2) in a separate block, provided that you select the *multi-level* indicator in the view data. You see all the assemblies that exist for components of the previous level.

An assembly is not exploded under certain circumstances.

See also: [When is a BOM Explosion Terminated? \[Page 397\]](#)

The next level down is not displayed until all the components on the level above have been listed.

BOM Explosion Level by Level



Assemblies and components that occur more than once in the structure are shown more than once.

Displaying a Multi-Level BOM Explosion

Use

This reporting function determines all components (assemblies and individual parts) in a product and displays them in their structural context for production.

This reporting function is available to you for the following BOM types:

- Material BOMs
- Order BOMs
- Work breakdown structure BOMs

Procedure

1. In the SAP Easy Access Menu select *Logistics* → *Production* → *Master data* → *Bills of material* → *Reporting* → *BOM explosion* → <BOM type> → *Multi-Level BOM*.

The *Multi-Level BOM: Initial Screen* appears in which you maintain the same fields as for the *level-by-level* function.

2. Enter the data that identifies your BOM (such as *Material*, *Plant*, and *Alternative*, if appropriate).
3. In the *Application* field, enter the key of the procedure for automatic alternative determination.
4. Enter the data for [Selecting a BOM \[Page 373\]](#).
5. Click  to determine the selection criteria for the BOM explosion.

See also: [Selection Criteria for BOM Explosion \[Page 376\]](#)

6. Click .

Result

You see a list of all items that fulfill your selection criteria. In the *Multi-level BOM* list, you immediately see whether a component is an assembly – the main difference between this and a level-by-level BOM explosion.

- The quantities refer to the required quantity displayed in the list header.
- The components of the subordinate assembly are inset directly below, with the next number up to show that this is the next level. If a component is an assembly, the explosion continues immediately.

The list of components on any level is interrupted each time a component that is an assembly occurs. After the list of items in the subordinate BOM, the list is continued on the superior level.



Assemblies and components that occur more than once in the structure are shown more than once.

Displaying a Multi-Level BOM Explosion

Displaying a Summarized BOM

Use

In certain application areas in a company, such as material requirements planning (MRP) and costing, you need a quick overview of all the parts required to make a product. This reporting function produces a **complete** count of the assemblies and individual components, which you can restrict using various criteria.

This reporting function is available to you for the following BOM types:

- Material BOMs
- Order BOMs
- Work breakdown structure BOMs

Procedure

1. In the SAP Easy Access Menu select *Logistics* → *Production* → *Master data* → *Bills of material* → *Reporting* → *BOM explosion* → <BOM type> → *Multi-Level BOM*.

You see the Multi-level BOM initial screen, where you can maintain the same fields as for the BOM level by level function.

2. Enter the data that identifies your BOM (such as *Material*, *Plant*, and *Alternative*, if appropriate).
3. In the *Application* field, enter the key of the procedure for automatic alternative determination.
4. Enter the data for [Selecting a BOM \[Page 373\]](#).
5. Click  to determine the selection criteria for the BOM explosion.

See: [BOM explosions, selection criteria \[Page 376\]](#).

You can maintain the following additional fields for this reporting function:

- Sort
 - Component
 - Sub-assemblies
6. Click .
- You see a list of all items that fulfill your selection criteria. The quantities refer to the required quantity displayed in the list header.
- This reporting function produces a **complete** count of the assemblies and other components across all levels in a product structure.
 - This list does not show you the structure of the product. Assemblies and individual components which occur more than once in the product are displayed as one item, with a sum total item quantity.
 - Displaying an assembly as a component is optional.

Additional BOM Explosion Functions

Additional BOM Explosion Functions

From the list of items you produce, you can obtain further information. The following display options are supported for the components in the list:

[Displaying Item Data from a BOM Explosion \[Page 391\]](#)

[Displaying Master Record Detail Data \[Page 392\]](#)

[Displaying a Where-Used List from a BOM Explosion \[Page 393\]](#)

Displaying Item Data from a BOM Explosion

How to display item data for a component in the list

1. Place the cursor on the line containing the component whose item data you want to display.
2. Choose  (Goto → *Item data* or double-click).

For the selected item you see the *Item: All data* screen.

See also:

[Displaying Item Data \[Page 263\]](#)

Displaying Master Record Detail Data

Displaying Master Record Detail Data

How to display the master record for a component in the list:

1. Place the cursor on the line containing the component whose master data you want to display.
2. Click  (*Environment* → *Detail*).

You see the master record of the component:

<i>Material item:</i>	material master, for example, engineering/design data
<i>Document item:</i>	document info record, basic data
<i>Class item:</i>	class data, for example, basic data

You can use all active master record functions.

Displaying a Where-Used List from a BOM Explosion

How to display a where-used list for an item in the list in other BOMs:

1. Place the cursor on the line containing the component for which you want to display a where-used list.
2. Click  (*Environment* → *Where-used list*).

You see a list of all the BOMs in which this item is used. From this list, you can use all active functions for where-used lists.

See also:

[Additional functions for a where-used list \[Page 410\]](#)

Displaying a Multi-Level BOM in Graphical Form

Displaying a Multi-Level BOM in Graphical Form

If you want to see the structure of a BOM in graphical form, choose *Goto* → *Graphics*.



This function is only available for variable lists.

If you have restricted the selection criteria for explosion in such a way that no coherent structure exists, this function may be inactive.

The time it takes to set up the screen depends on how your work center is equipped and on the current load of the system.

The system goes to the graphical display function and shows the structure of the selected BOM.

The screen structure depends on various settings in the graphical display function. For example, by choosing *Settings*, you can define how the screen is divided and which colors are assigned.

In the standard settings, the screen is divided into the display area and the navigation area, which are described below.

- **Display area**

In this area, the components are displayed according to the structure of the BOM.

For each component, you see the following data:

- Item category
- Item number
- Component
- Component description
- Quantity and unit of measure

The different item categories are shown in different colors.

In the vertical and horizontal scroll bars, you can change the area, which is displayed.

- **Navigation area**

In this area, you see the entire structure of the BOM in graphical form. The system marks the section shown in the display area.

If the BOM you are displaying is large, this can help you to see where you are.

To display component data:

1. In the display area, select the component for which you want to display additional data.
2. Then choose one of the following functions:

<i>Item</i>	Item data from the BOM
<i>Details</i>	Data from the master record
<i>Document</i>	Original application file for a document
<i>Use</i>	Where-used list for component in other assemblies

3. To print the graphical hierarchy, choose *Graphics* → *Print*.

Displaying a Multi-Level BOM in Graphical Form

The following print functions are supported:

- *On a printer*
- *As a Graneda Metafile*
- *In Postscript*
- In HPGL

When is a Material BOM Not Exploded?

When is a Material BOM Not Exploded?

A BOM is not exploded in the following situations:

- No BOM is effective:
 - On the explosion date and in the given area of validity
 - For the given effectivity parameters
- The BOM has a deletion indicator.
- The BOM is a multiple BOM, and has no alternative that matches the lot size for your required quantity.
- No BOM matches the selection criteria of the BOM application you selected.
- This is possible in the following situations, for example:
 - The application does not take all BOM usages into account.
For example, the application only takes BOMs that are relevant to production into account, so a BOM that is relevant to sales and distribution is not exploded.
 - The application selects a specific alternative on the explosion date you require. The material master record supports alternative determination by *Explosion date*.
If the specified alternative is not valid on the explosion date, the BOM is not exploded.
 - The application takes production versions in the material master record into account, but no production version has a BOM that is valid on the explosion date you require. The material master record supports alternative determination by *Production version*.
The system only explodes the BOM defined for the production version that matches the alternative and/or usage entered on the explosion date required.
 - The application only takes BOMs with certain status indicators into account.
For example, the application for MRP only explodes BOMs that have at least the status *Explosion for MRP*.

When is a BOM Explosion Terminated?

In certain situations, the following checks can stop an assembly from being exploded:

- Recursiveness check
- Authorization check



In the list, you see a note on why the assembly has not been exploded. The note is in the component description line.

Recursiveness check

In the general item data of the BOM component that causes recursiveness, you can maintain the following indicators:

- *BOM is recursive*
- *Recursiveness allowed*

See [Recursiveness Check \[Page 164\]](#).

If one of these indicator is set for a component, the BOM explosion stops at this component.

The following exception messages are defined:

REKU	Recursiveness recognized by system
NREK	Recursiveness allowed

Authorization check

In the BOM header, you can use the *Authorization group* to control access to the entire BOM. If access to a BOM is restricted by the authorization group, you can only access the BOM if your user master record contains the authorization group defined.

If you do not have the authorization required, the BOM explosion stops at the component (assembly) for which you are not authorized.

The following exception message is defined:

NBER	Authorization group for component not in user profile
-------------	---

Where-Used List

Where-Used List

To determine which BOMs an object is used in, you need to start a “bottom-up” analysis of BOMs.

You can produce a where-used list for the following objects:

- *Material (multi-level)*
- *Document (single-level)*
- *Class (single-level)*

This section describes the where-used list for materials in detail. You can produce where-used lists for documents and classes in the same way.

Use

A where-used list answers the question: **Where is an object (for example, material) used, and in what quantity?**

This question is especially important, for example, if objects (such as materials) are used in more than one context.

For example, you require this information to:

- Determine requirements for a specific material
- Select products that are affected by a change to an individual part
- Find assemblies that will be delayed if, for example, there is a delay in the delivery of a raw material
- Calculate the effect on the cost of a product if the price of a raw material rises

Defining a Where-Used List on the Initial Screen

You can maintain some of the selection criteria for a where-used list in the following datasets on the initial screen:

- *Where-used lists, types*
- *Selection*
- *Use in*

Where-used lists, types

In this dataset, you can define whether the system determines BOMs that contain the object (for example, material) directly as a material item or indirectly as an object classified in a class item. You must set at least one of these indicators for your where-used list.

- **Direct**
The system lists all BOMs that contain the object (for example, material) as a component.
- **Via classes**
The system lists all BOMs that contain the object (for example, material) as an object classified in a class item.

If you set this indicator, the system automatically sets the *Cl (object via classes)* indicator next to each BOM where the object is classified in a class item.

Selection

You can display a where-used list according to different effectivity periods. Your entries in the fields *Valid from* and *Valid to* define the period in which you want to determine where the object is used.

The following table shows which entries you make to define the effectivity period you require.

User Entries for Effectivity

Effectivity period for where-used list	User entries for effectivity period
On a specific date	<i>Valid-from</i> date Date on which you want to display the BOM <i>Valid-to</i> date Same entry as <i>Valid-from</i> date
Within a time period	<i>Valid-from</i> date Date at beginning of time period <i>Valid-to</i> date Date at end of time period
Over its entire validity period	<i>Valid-from</i> date Deletion character "!" <i>Valid-to</i> date No entry

Defining a Where-Used List on the Initial Screen

Up to a specific date	<i>Valid-from date</i> Deletion character "!" <i>Valid-to date</i> Date up to which you want to display the BOM
At a specific revision level	Revision level Revision level assigned to a change with a change number. The system determines the <i>Valid-from date</i> from the assigned change master record.

Use in BOMs

In this dataset, you can select the BOM categories that are relevant to your where-used list. On the initial screen, you only see certain BOM categories for the different objects (for example, material or document). For example, you cannot enter a material item in a document structure, so you cannot select document structure as a BOM category for a material where-used list.

Where-used lists for materials and documents are supported for the following BOM categories:

- Equipment BOM
- Order BOM
- Material BOMs
- Work breakdown structure (WBS) BOM
- Standard BOM
- Functional location BOMs
- Document structure (not for materials)

A class can only be a component in a material BOM, so the where-used list for a class does not contain the *Use in* dataset.

Selection Criteria for the Where-Used List

You can define various selection criteria to control the where-used list. This means that you can produce a where-used list for an object (for example, material or document) that only contains information specific to your application area. You define these selection criteria on a special screen. To see this screen, click .

Using the *Variable List* indicator, you choose the layout of the list. If you set this indicator, the system displays the additional function fields that are only available for variable lists.

See also:

[Defining a View for a Where-Used List \[Page 402\]](#)

[Restricting the View for a Where-Used List \[Page 404\]](#)

[Extending the View for the Where-Used List \[Page 405\]](#) (part of the functions only in variable lists)

[Display Profile for Lists \[Page 355\]](#) (only variable lists)

Defining a View for a Where-Used List

Defining a View for a Where-Used List

You can influence a where-used list by entering the following quantities: required quantity and resulting quantity. When you enter one of these quantities, the system calculates the other one.

- **Required quantity**

The required quantity is interpreted as a component quantity (in the base unit of measure) for determining where-used lists.

See also:

[Required Quantity \[Page 254\]](#)

When you enter a required quantity, the system calculates the resulting quantity. This tells you how many assemblies you can make with the required quantity of the material you entered.

The following formula is used to calculate the resulting quantity:

Resulting quantity =	$\frac{\text{Base quantity} * \text{Required quantity}}{\text{Component quantity}}$
----------------------	---



The material *Paint* is produced from the components PP-PAINT01 and PP-WATER. The material *Paint* has a multiple BOM with three alternatives for different lot sizes. The required quantity of the component PP-WATER varies in accordance with the lot size of the alternative. For example, for each alternative you obtain different resulting quantities of the component *Paint* when you use 30 liters of PP-WATER.

- **Resulting quantity**

The quantity of an assembly material that is produced with a specific required quantity is the resulting quantity. This replaces the base quantity in where-used lists.

When you enter a resulting quantity, the system calculates the required quantity.

The required quantity tells you how much of the material is required to produce the resulting quantity of the assembly that you entered. When you change the resulting quantity, the required quantity changes as well.

The system calculates the required quantity (= new base quantity) as follows:

Required quantity =	$\frac{\text{Component quantity} * \text{Resulting quantity}}{\text{Base quantity}}$
---------------------	--



The following table shows how many liters of the component PP-WATER are required to produce 100 liters of paint for the three alternatives of BOM PP-FARB01.

Calculation of Required Quantity from Resulting Quantity

Defining a View for a Where-Used List

Material number (Alternative)	Required quantity (liters)	Resulting quantity (liters)
PP-PAINT01 (Alt. 01)	50.000	100.000
PP-PAINT01 (Alt. 02)	65.000	100.000
PP-PAINT01 (Alt. 03)	50.000	100.000

For an example of a multiple BOM, see [Before You Create a Multiple BOM \[Page 294\]](#).

Restricting the View for a Where-Used List

Restricting the View for a Where-Used List

You can use the following data to restrict a where-used list:

- Plant

The where-used list only applies to the plant you enter. If you do not enter a plant (value **Blank**), the system searches for group BOMs.

If you want to search in all plants, enter the special character “*”. This special character is only checked in the first explosion level. After that, the explosion only reads the plants where the object is used in the first level.

- Item category

The system only searches for BOMs that contain the object with the item category you enter.

- Usage

The system only searches for BOMs that have the usage you enter.

Extending the View for a Where-Used List

You can obtain additional information by setting the following indicators:

- **Long text** (only variable lists)

Set this indicator if you want to see the complete long text for the item.

- **Multi-level**

This function is supported for where-used lists for materials, and is only active if you only select *Material BOMs* in the *Use in* dataset.

Single-level where-used list

If you want to produce a **single-level** where-used list, do **not** set this indicator. For example, the list only displays BOMs in which the material (or a class to which it is assigned) occurs on level 1.



Material **C** is used in the BOM for material **B**. The BOM for material **B** is a sub-assembly, which is included as a component in the BOM for material **A**.

If you produce a *single-level* where-used list for material **C**, you only see the BOM for material **B** in the list.

Multi-level where-used list

If you want to produce a where-used list for the entire explosion path, set this indicator.



Material **C** is used in the BOM for material **B**. The BOM for material **B** is a sub-assembly, which is included as a component in the BOM for the finished product (material **A**).

If you execute a *multi-level* where-used list for material **C**, you see the following levels:

- 1. Level: Material B (material B is the header material of the sub-assembly)
- 2. Level: Material A (material A is the finished product)

Where-Used List for a Material

Where-Used List for a Material

You can produce a where-used list for a material on either a single-level or a multi-level basis.

To display a where-used list for a material:

1. Choose *Logistics* → *Production* → *Master data* → *Bills of material* → *Reporting* → *Usage* → *Material*.

The *Usage* screen appears. *Material: Initial screen*.

2. Enter the material for which you want to display a where-used list.
3. Enter your data in the *Type of where-used list*, *Selection*, and *Use in datasets*, if required.

This data allows you to control that BOMs are read for the where-used list on the initial screen. See [Defining a Where-Used List on the Initial Screen \[Page 399\]](#)

4. Click .

You see the *View* screen, on which you can define selection criteria for the where-used list. See [Selection Criteria for a Where-Used List \[Page 401\]](#)

5. Click .

- You see a list of all the BOMs in which the material is used in accordance with the selection criteria you entered. This list can, for example, contain material BOMs and equipment BOMs that contain the material. First you see all the material BOMs in which the material is used, then the equipment BOMs.
- First, the list shows the BOM data that identifies the BOM, then the item data for the selected material – for example, item number, quantity, and unit of measure.
- If you selected a single-level where-used list, the system only determines the BOMs where the material is used in directly as a component. The BOMs are all shown with explosion level 1.
See [Extending the View for a Where-Used List \[Page 405\]](#)
- If you selected a multi-level where-used list, you see where the BOM is used at any level. A BOM that contains the material directly is shown with explosion level 1. If the material is used in sub-assemblies, the list explodes the entire BOM hierarchy, with a number showing the successive explosion levels.

You see a dividing line between the different paths, if the next path starts or continues on a level with a lower number.

Where-Used List for a Document

You can produce a single-level where-used list for a document.

- Choose *Reporting* → *Where-used list* → *Document single-lev.*
- To identify the document, enter the document key data:
 - *Document number*
 - *Document type*
 - *Document part*
 - *Document version*
- Then proceed as for a material where-used list.

See also:

[Where-Used List for a Material \[Page 406\]](#)

Where-Used List for a Class

Where-Used List for a Class

You can produce a single-level where-used list for a class. You can only use classes as BOM items for configurable materials, so only configurable material BOMs are read by this function.

- Choose *Reporting* → *Where-used list* → *Class single-level*.
- To identify the class, enter the class name and class type.
- Then proceed as for a material where-used list.

See also:

[Where-Used List for a Material \[Page 406\]](#)

Exception Messages for a Where-Used List

To display the exception messages, choose *Edit* → *Goto* → *Exception msgs*.

- If there are exception messages for the material where-used list, you see these messages.

The following exception messages may appear:

- *BOM marked for deletion*
 - *Recursiveness check off*
 - *BOM is recursive*
 - *No authorization for access <authorization group>*
- If you choose *Edit* → *Goto* → *Exception msgs* and the screen remains the same, it means that there are no exception messages.

Additional Functions for a Where-Used List

Additional Functions for a Where-Used List

From the list of BOMs determined, you can obtain further information. The standard system supports the following display options for the BOMs in the list:

[Displaying Item Data from a Where-Used List \[Page 411\]](#)

[Displaying Detail Data from a Where-Used List \[Page 412\]](#)

[Displaying a Where-Used List from a Where-Used List \[Page 413\]](#)

Displaying Item Data from a Where-Used List

Each BOM shown in the where-used list is part of a where-used path for the selected object (for example, material).

From the list, you can display the item data defined in a superior assembly for each object on any explosion level.



Material **C** is used in the BOM for material **B**. The BOM for material **B** is a sub-assembly that is used as a component in the BOM for material **A**.

In the multi-level where-used list, the following explosion path is found for material **C**:

Level	Material
1	Material B
2	Material A

How to display item data for an object from a where-used list:

1. Place the cursor on the line containing the object whose (subordinate) item data you want to see. The item has a lower explosion level in the explosion path.

If you want to see the item data for material **B** in the BOM for material **A**, for example, place the cursor on the line containing material **A**.

2. Choose *Items or Environment* → *Item data*.

You see the *General data detail screen* for the item you selected (for example, material **A**). If you want to see more detail screens for the item, confirm your entries.

See also:

[Displaying Item Data \[Page 263\]](#)

Displaying Detail Data from a Where-Used List

Displaying Detail Data from a Where-Used List

How to display detail data from the master record of an object from a where-used list:

1. Place the cursor on the line containing the object whose master data you want to see.
2. Choose *Detail* or *Goto* → *Detail*.

You see the master record for the BOM object:

<i>Material:</i>	material master record, for example, engineering/design data
<i>Document:</i>	document info record, basic data
<i>Equipment:</i>	equipment master record
<i>Functional location:</i>	master record of functional location

You can use all the active functions for the master record.

Displaying a Where-Used List from a Where-Used List

Each object in the where-used list can be used as a component in another BOM.

How to display a where-used list for an object in other BOMs from a where-used list:

1. Place the cursor on the line containing the object for which you want to display a where-used list.
2. Choose *Where-used list* or *Environment* → *Where-used list*.

You see a list of all the BOMs in which the object is used. From this list, you can use all the active functions for a where-used list.

BOM Comparison

BOM Comparison

You can compare two different BOMs with each other. This can be useful, for example, if you have created more than one BOM for a specific material. For example:

- BOMs with different BOM usages
- BOMs with different change states or versions
- Different alternatives of a multiple BOM

This comparison is done per item.

See also:

[BOMs for a BOM Comparison \[Page 415\]](#)

[Settings for a BOM Comparison \[Page 416\]](#)

[Executing a BOM Comparison \[Page 418\]](#)

[Understanding the BOM Comparison Result \[Page 419\]](#)

BOMs for a BOM Comparison

We refer to the BOMs being compared as the primary BOM and the secondary BOM:

Primary BOM	Secondary BOM
The item data of this BOM is used as a starting point for the comparison.	The item data of this BOM is compared with the item data of the primary BOM.

BOM Categories for Comparison

You can compare different categories of BOM with each other.

You can compare the following BOM categories:

- Material BOM
- Document structure
- Equipment BOM
- Functional location BOM
- Order BOM
- Work breakdown structure (WBS) BOM
- Production order "BOM"

The first time you call the *BOM comparison* function, you see a special screen for selecting the BOM category of the primary and secondary BOMs.

The system saves the BOM categories you select for your user. The next time you call the comparison function, the BOM categories are preselected on the entry screen.

You can change the BOM category for the primary BOM and secondary BOM separately. To do this, choose *Goto* → *<Primary/Sec. BOM> category* → *<object type>* (for example, *Primary BOM category* → *Material*).

Settings for a BOM Comparison

Settings for a BOM Comparison

Comparison Levels

You can set the levels of detail for a comparison as follows:

Single-level comparison	Multi-level comparison
Only items on the top explosion level are compared.	Items that are assemblies are exploded and compared down to their lowest level.
To ensure that the BOM with the application-specific data you require is exploded, enter the <i>BOM usage</i> .	To ensure that the BOM with the application-specific data you require is exploded, enter the <i>Application</i> .
	The different explosion levels are exploded as for a multi-level BOM.

Components That Are Used More than Once

A BOM may contain the same component in several different places. **Before** you start the comparison, you define how you want component quantities for these components to be displayed: *summarized* or *differentiated*.

The following fields are displayed for both comparison types:

- *Quantity*
- *Unit of measure*
- *Item category*

The following table shows the differences between these two comparison types.

Summarized comparison	Differentiated comparison
The individual component quantities are added together to make a total component quantity.	Each occurrence of the item is shown separately.
If a component that is used more than once in a BOM has different field values (for example, non-stock item and stock item), no value is shown in the field.	You can select fields for comparison and display the values on the detail screen.
You see the difference in total component quantity for the two BOMs.	You see the individual explosion levels for each item.

Fields for Differentiated Comparison

The system displays the items in the primary or secondary BOM that match your selection criteria in the *comparison result* with the following data:

- *Quantity*
- *Unit of measure*
- *Item category*

Settings for a BOM Comparison

In the *Differentiated comparison* function, this data describes the item. The data is **not** automatically compared. In a differentiated comparison, you have to select the data you want to compare by selecting *Fields for comparison*, such as *Quantity*, or *Item number*.

Before you start the comparison, select the fields for comparison for the different object types:

- Relevant to all item categories
- Relevant to material items
- Relevant to document items
- Relevant to text items
- Relevant to intra materials



You can save your selection of fields for comparison. The system saves fields you select for your user. The next time you call the differentiated comparison function, these values are preselected.

Selection Criteria for Defining the View

You define selection criteria in the *View* function in three datasets:

- You can maintain the datasets of the *Define view* and *Restrict view* functions as for other BOM reporting functions.
- The following special points apply to the *Extend view* function:
 - If you want to compare sub-items, set the *Compare sub-items* indicator.
You can compare sub-items either by sub-item number or by installation point.
 - You can compare object dependencies.



The converted form of dependencies is compared. Even small differences in the contents of object dependencies lead to the comparison result *not equal*.

- You can display sub-assemblies after the superior assembly and compare them.

Executing a BOM Comparison



Executing a BOM Comparison

To execute a BOM comparison:

1. Choose *Logistics* → *Production* → *Master data* → *Bills of material* → *Reporting* → *BOM comparison*.

The first time you call the *BOM comparison* function, select the BOM categories of the primary and secondary BOMs. See [BOMs for a BOM Comparison \[Page 415\]](#)

2. On the *BOM Comparison: Initial Screen*, enter the data that identifies the primary and secondary BOM you require, plus validity data.

- Select the explosion level (Click  *Single level* or  *Multi level*).
- If you want to do a differentiated comparison, select the fields for comparison that you require. To do this, choose *Goto* → *Fields for comparison*. Save your selection.

If you work with the ALV list, you can then select the columns that you want to display via the button  in the result screen.

- On the initial screen, choose  to define the scope and selection criteria for BOM components.

3. Start the comparison:

- If you want to summarize individual component quantities to make a total component quantity, choose  *Summarized*.

You see a  total icon next to items that have been summarized.

- If you want to display each occurrence of a component separately, choose  *Differentiated*.

On the result screen, you also see the explosion level for each item in the primary and secondary BOMs.

If there are differences between the two BOMs, you see the *BOM Comparison: Result screen*.

See also:

[Understanding the BOM Comparison Result \[Page 419\]](#)

Understanding the BOM Comparison Result



The result screen of the BOM comparison shows all the components that are in both the primary BOM and the secondary BOM. You see the fields *Quantity*, *Unit of measure* and *Item category*.

Items with the same object key (for example, material number) are shown next to each other.

The result screen is divided into several columns:

- *Component and Description*
This column shows all the items in the primary and secondary BOMs.
- *Primary BOMs*
This column shows the field values for items in the primary BOM.
- *Comparison results*

Here the comparison results are displayed graphically.

Icon	Meaning
	The item only exists in one of the BOMs.
	The compared field values are the same in both BOMs.
	The item is used in a similar way in both BOMs, but means that at least one of the compared field values is different.

- *Secondary BOMs*
This column shows the field values for items in the secondary BOM.

To change the result screen:

1. You can define which items you want to show and hide.

For example, you can hide all the items that are the same in both BOMs. To do this: Choose *Extras* → *Identical components* → *Hide identical*.



For a Summarized comparison:

- Summarized items are indicated by the  symbol.
The system calculates the quantity difference between the primary BOM and the secondary BOM and displays this.
- If no value is shown for the *Quantity*, *Unit of measure* and *Item category* fields of a summarized item, this means that at least two of the summarized items have different field values.

For a differentiated comparison:

- For each item, the level in the primary BOM and secondary BOM is also shown.
- If more than one item in the secondary BOM is matched to an item in the primary BOM, all the secondary BOM items are listed in the same color against the primary BOM item.

Understanding the BOM Comparison Result

2. If you want to display the values of the selected comparison fields place the cursor over the symbol (such as ) of the relevant item line. To do this, choose *Extras* → *Compare details*.
 - Different values are shown in a different color.
 - Sub-items are listed separately according to the view settings you defined.
 - In a dialog box, you can decide whether to hide or show the fields that are not relevant to your comparison.
 - These fields are displayed dynamically according to the following criteria:
 - Different values
 - Identical values
 - Without values
3. If you want to hide or show the description of a component, choose *Extras* → *Component description* → *Hide/Show* (only variable lists - in the ALV-lists select the button  for the column selection).
4. If you want to display a where-used list for an item, place the cursor on the item in either the primary BOM or secondary BOM column.
 - Choose *Goto* → *Where-used list*.
5. If you want to see the item data for the primary or secondary BOM, place the cursor on the column for the BOM you require.
 - Choose *Goto* → *BOM item*.

Displaying Change Documents

If you change a BOM **without** a change number, the change objects in the BOM (for example, BOM header or item) are changed directly. The system does not duplicate header or item records. As a result, you can no longer display the pre-change state of the BOM.

However, changes are logged in change documents, which contain both the old and the new field values. The system stores BOM data in different tables, for example, BOM header data is stored in table STKO and BOM item data is stored in table STPO. The system writes object changes to the appropriate table, and change documents are generated on the basis of these tables.

Change documents are created for the following BOM categories:

- Material BOM
- Document structure
- Equipment BOM
- Functional location BOM
- Standard BOM
- Order BOM

You can display change documents in the following situations:

[Displaying Change Documents from the Main Menu \[Page 422\]](#)

[Displaying Change Documents from the BOM \[Page 424\]](#)

Displaying Change Documents from the Main Menu

Displaying Change Documents from the Main Menu

To display change documents from the main menu:

1. Choose *Reporting* → *Change documents* → *<BOM category>* (for example, *Material BOM*).

You see the initial screen, on which you enter the BOM for which you want to display change documents. Enter the following data:

- *Material*
- *Plant*
- *Usage (optional)*

2. Confirm your entries.
 - If the BOM data you enter identifies one individual BOM, you see the *Display change documents: <BOM Category>* screen.
 - If BOMs of different usages exist for the *Material* and *Plant* you entered, and you did not enter a usage on the initial screen, you see a list of the BOMs found.
 - If BOMs exist in different plants for the *Material* and *Usage* you entered, and you did not enter a plant on the initial screen, you see a list of the BOMs found.

3. Select the BOM(s) whose change documents you want to display and choose *BOM*.

You see the *Display Change documents: <BOM Category>* screen.

4. On the *Display change documents: <BOM category>* screen, enter the selection date. The system lists the change documents generated **after** this selection date.

A default value is stored in the system. This is calculated as follows:

Default date = Today's date - 90 days

5. Display the change documents. You have the following options:

- *Document overview*

You see a list of all change documents generated by the system as of the date you entered. You see the following data:

- Document number
- Date and time
- User who made the change
- Object ID

From this list, you can display individual change documents. To do this, place the cursor on a line containing the document you require. Choose *Display documents*. You see the document you selected.

- *Display documents full*

You see all the change documents, listed one after the other.

To display change documents sorted according to specific object changes:

Displaying Change Documents from the Main Menu

1. On the *Display change documents: <BOM category>* screen, enter the data of the BOM whose change documents you want to display.
2. Enter a selection date. The system lists the change documents generated **after** this selection date.
3. Choose *Goto → Display documents → <object>*.

You can display object changes for the following objects:

- *Full* (all objects)
- *Central data*
- *Header*
- *Item*
- *Sub-item*
- *Material* (only active for material BOMs)
- *Equipment* (only active for equipment BOMs)
- *Functional location* (only active for functional location BOMs)
- *Sales order* (only active for order BOMs)

Displaying Change Documents from the BOM

Displaying Change Documents from the BOM

When you are processing a BOM, you can display change documents at any time.

You follow the same steps as for calling the function from the main menu. However, you do not need to enter the data for identifying the BOM.

To display change documents in a BOM processing function:

1. Choose *Environment* → *Change documents*.
You see the *Display Change documents: <BOM Category>* screen.
2. For information on further processing options, see [Displaying Change Documents from the Main Menu \[Page 422\]](#).

Setting up BOM Groups

A BOM group is used to group together material BOMs that describe one product or several similar products.

A BOM group can be:

- All variants of a variant BOM
- All alternatives of a multiple BOM

The material BOMs that are grouped together in a BOM group are stored under **one** internal number by the system.

Within the BOM group, each item has a unique item ID. You can enter the same item ID for logically related items, such as different versions of an item. **See also:** [Identifying BOM Items \[Page 140\]](#).

Examples of BOM Groups

The following graphic shows all the variants of a variant BOM that are grouped together to form a BOM group.

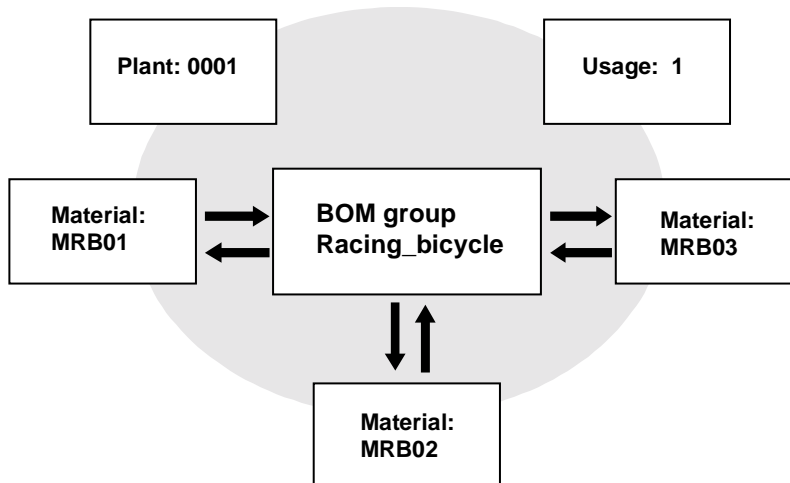

The following graphic shows all the alternatives of a multiple BOM that are grouped together to form a BOM group.

Setting up BOM Groups

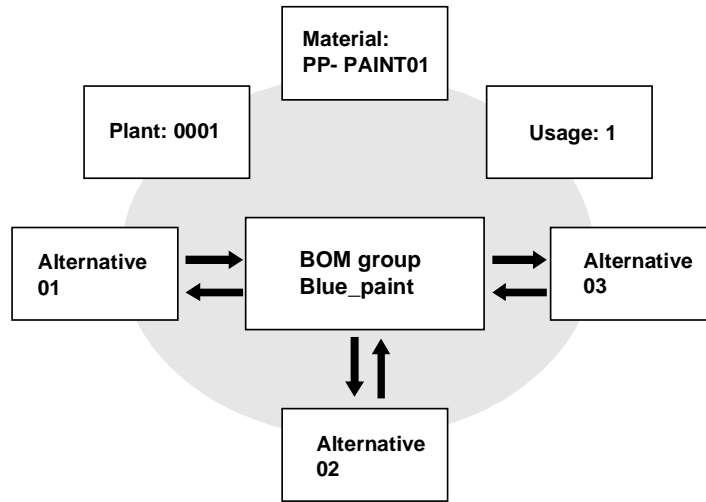

Hints on Changing a BOM Group

You can choose *BOM group* → *Change* to create or change one or more items in a BOM group. If you want to edit an item that is used with the same data in more than one variant in the BOM group (non-variable part), choose *BOM group* → *Change*.

If you want to change a variant part that is only used in one variant of the BOM group, choose *Material BOM* → *Change*.



Once you change one BOM in a BOM group (one variant in a variant BOM or one alternative in a multiple BOM) with a change number, all BOMs in the BOM group have a history requirement. This means that you can only process BOMs in the group with a change number.

Changing BOM Groups

Changing BOM Groups

How to change a BOM group:

1. Choose *Logistics* → *Production* → *Master data* → *Bills of material* → *Bill of material* → *Material BOM* → *BOM group* → *Change*.

The *Change BOM group* initial screen appears. Initial screen.

If a user parameter for the *Usage* field is defined as a default value in your user master record, the system enters either this default value or the last value entered.

2. In the *Plant* field, enter the plant in which you want to change the BOM group. If you want to change a BOM group for an entire group, do not enter a plant.
3. To identify the BOM group further, you have two options:
Either enter the name of the BOM group in the *BOM group* field or enter the material and usage.

If you make an entry in the *BOM group* field, the system ignores any entries you make for the *Material* and *Usage*.

4. In the *Validity* dataset, define the validity period for which you want to change the BOM group.

If you want to change the BOM group historically, enter a change number. The system determines the valid-from date from the change master record.

5. Confirm your entries.

If your data is correct, you see the *Summarized BOM* screen.

6. This screen contains all the items in the BOM group, which are valid in the validity period you entered. The system assigns each item to the alternative in which it is used.



Any change you make on this screen affects all the alternatives assigned to the BOM group.

You can, for example:

- enter a new item

If you enter a new item, set the indicator for the alternative for which the new item is valid.

- change the item quantity

In this case, the changed quantity applies to all alternatives to which the item is assigned.

If you only want to change the item quantity for some of the alternatives that use it, create the item with the new item quantity and assign it to the alternatives concerned.

7. If you no longer want an item to be used in one of the alternatives to which it is assigned, or you want to assign an item to an alternative in which it was not used before, change the assignment of items to alternatives.

- Select the item you require.

Changing BOM Groups

- Choose *Alternatives (item in alternatives)*.

You see the *Item in alternative(s)* screen, on which you can edit the *Assignment* field for each alternative of the BOM group.

Displaying a BOM Group

Displaying a BOM Group

You use this function if you want to display a summary of all the items in the BOMs in a BOM group. This overview shows you which alternatives or variants contain a specific item.

See also:

[Before You Display a BOM \[Page 431\]](#)

[Initial Screen \[Page 432\]](#)

[Displaying a Summarized BOM \[Page 433\]](#)

Before You Display a BOM Group

You have two options for identifying a BOM group:

- Entering the BOM group

On the *Detail screen: Header: Quantities/Long text* you can enter a common name for the BOMs that belong together in the *BOM group* field. This alphanumeric character string is used to identify the BOM group in a specific plant or group.

If you do not make an entry in the *Plant* field (value **Blank**), the system looks for a group BOM. If you want to display the BOM group in a specific plant, enter the plant.



In BOM maintenance, entering a BOM group is optional. If you do not define a BOM group, you can only use this display function if you enter the material and usage of the related BOMs.

- Entering the material, plant, and usage

If you do not make an entry in the *Plant* field (value **Blank**), the system looks for a group BOM. If you want to display the BOM group in a specific plant, enter the plant.

Validity period

To restrict the validity period for displaying the BOM group, you have the same options as for displaying a simple BOM.

See also:

[Validity Period \[Page 253\]](#)

Maintaining the for Display BOM Group Initial Screen

Maintaining the for *Display BOM Group* Initial Screen

To maintain the initial screen for displaying a BOM group:

1. Choose *Material BOM* → *BOM group* → *Display*.

You see the initial screen of the *Display BOM group* function.

- If a user parameter for the *Usage* field is defined as a default value in your user master record, the system enters either this default value or the last value entered.
- In the standard R/3 System, today's date is the default value for the *Valid from* and *Valid to* fields.

In Customizing for *Production*, you can define that the system low date is the default valid-from and valid-to date for BOMs (01.01.1900) instead of the current date, by choosing *Bill of Material* → *Control Data for Bills of Material* → *Define modification parameters*.

2. In the *Plant* field, enter the plant in which you want to display the BOM group. If you want to display a BOM group for an entire group, do not enter a plant.
3. To identify the BOM group further, you have two options:

Either enter the name of the BOM group in the *BOM group* field or enter the material and usage.

If you make an entry in the *BOM group* field, the system ignores any entries you make for the *Material* and *Usage*.

4. In the *Validity* dataset, define the validity period for which you want to display the BOM group.
5. Confirm your entries.

The system makes a series of checks. For example, the system checks whether the BOM is valid in the plant you entered.

If no items are valid in the validity period you entered, you see the following message:

No items valid on <valid-from date>

Displaying a Summarized BOM Group

If the system checks are successful, you see the *Summarized BOM* screen. On this screen, you see a list of all items in the BOM group.

1. At the top of the screen, you see the selected header data of the BOM group, such as:

- *BOM group*
- *Plant*
- *BOM description*
- *Material*
- *Material description*

For a variant BOM, the *Material* field shows the material of the first variant.

2. In the second part of the screen, you see the summary of *BOM items*.

In the list header, you see all the fields:

- *Item number*
- *Component/component description*
- *Quantity and unit of measure (Un)*
- *Item category (ICt)*
- *Object dependencies – only for configurable BOMs*
- *List of alternatives (01 02..)*

The contents of this list are determined automatically. Depending on whether you are dealing with a multiple BOM or a variant BOM, you see either the names of the alternatives of the multiple BOM or the consecutive numbers of the variants of the variant BOM.

3. In the main part of the list, you see all items in the BOM group, sorted in ascending order by item number.

The system allocates each item to the alternative in which it is used.

In the list of alternatives, the system displays an indicator in the column for each alternative or variant in which each item is used.

On this overview, the first eight alternatives or variants are shown.

4. If more alternatives exist, you enter the alternative or variant from which you want to start the list in the *From alternative* field.

- If you want to see an overview of existing alternatives or variants first, choose:

Goto → *Alternative overview* for a multiple BOM

Goto → *More* → *Variant overview* for a variant BOM

5. You can sort and filter the items in the list, by choosing:

- *Edit* → *Sort*
 - by item number

Displaying a Summarized BOM Group

- by material number
- by sort string
- *Edit* → *More* → *Filter*
 - Material
 - Document
 - Without object
 - Item category

See also:

[Sorting Items \[Page 268\]](#)

[Filtering Items \[Page 265\]](#)

Filename: ppbdbom.doc
Directory: F:\Doku\Metrics\06_Print_CD\pdf_46c_reinexport\docs\en\docsvonwt
s
Template: C:\katrin\sapkeeh.dot
Title: BOMs (PP-BD-BOM)
Subject:
Author: SAP AG
Keywords:
Comments: Release 46C 12.07.2001
Creation Date: 12.07.01 13:45
Change Number: 3
Last Saved On: 12.07.01 14:11
Last Saved By: D024727
Last Printed On: 12.07.01 18:00
As of Last Complete Printing
Number of Pages: 434
Number of Words: 79.394 (approx.)
Number of Characters: 396.971 (approx.)